

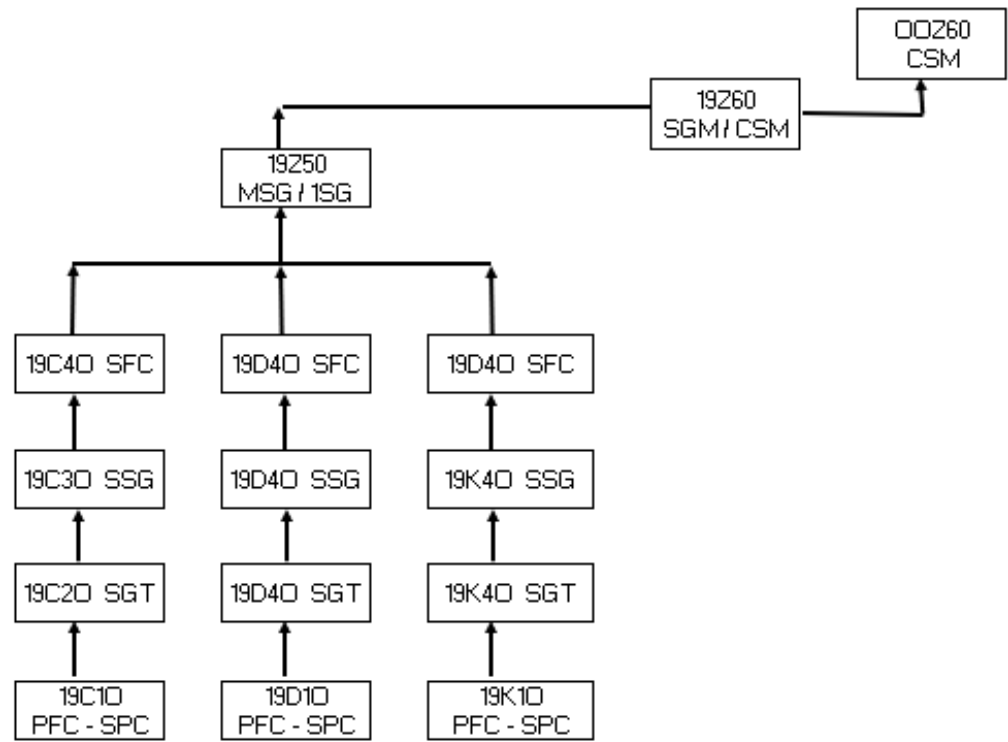

CMF 19 Progression Chart

19 C Bradley Crewman	19 D Cavalry Scout	19 K Armor Crewmember	19 Z Armor Senior Sergeant	Command Sergeant Major Nominative
----------------------------	--------------------------	-----------------------------	-------------------------------------	--









SUBSTITUTABILITY: None → Line of normal progression

Figure 10-19. CMF 19 - Armor Career Progression (Effective 202410)

19C Talent Development Model

Years of Service 2 4 6 8 10 12 14 16 18 20 22 24 26 28 30

Rank Position	 Driver	 Gunner	 BFV Commander	 Platoon Sergeant	 First Sergeant	 BN/BDE CSM
	Requires a <u>minimum</u> of 18-24 months to be considered KD complete. * See additional note below for SSG.					
Military Education Distributed Learning						
NCOPDS	BLC	ALC	SLC	MLC	SMC	NOM
Civilian Education Degree Program	Associate's Degree		Bachelor's Degree			Master's Degree
Broadening Opportunities (Not ordered in precedence)	PVT-SPC	SGT	SSG	SFC	MSG	SGM/CSM
	<i>No broadening opportunities exist</i>	<i>No broadening opportunities exist</i>	<ul style="list-style-type: none"> • AC/RC OC/T • Drill Sergeant • Instructor • MSI • Recruiter • SGL 	<ul style="list-style-type: none"> • AC/RC OC/T • CTC OC/T • Equal Opportunity Advisor • Inspector General • Instructor • MSI • Senior Drill Sergeant • SGL • Talent Management NCO • Career Management NCO 	<ul style="list-style-type: none"> • AC/RC OC/T • CTC OC/T • Equal Opportunity Advisor • Inspector General • SR Instructor • MSI • Senior Career Management NCO • Senior Talent Management NCO 	<ul style="list-style-type: none"> • Branch SGM • Chief Career Management NCO • Chief MSI • CSM O/C • CST SGM • DOTS SGM • CH Instructor • JMRC CSM • USAAC BDE CSM • USAAMA <ul style="list-style-type: none"> ▪ Executive Officer ▪ Instructor ▪ Training Developer
Functional Courses/Troop Schools (Earliest opportunities to attend courses, not all encompassing)	SPC	SGT	SSG	SFC	MSG	SGM
	<ul style="list-style-type: none"> • DTMS • Environmental Compliance • Unit Armorer 	<ul style="list-style-type: none"> • BFV Master Gunner • Master Driver • Safety • HAZMAT • Unit Prevention Leader 	<ul style="list-style-type: none"> • BFV Commander Course • Basic Recruiter Course • Battle Staff NCO • CFDIC • Drill Sergeant • Equal Opportunity • Master Fitness • Master Resiliency • Unit Movement Officer (UMO) 	<ul style="list-style-type: none"> • Cavalry Leader Course • Inspector General • Maneuver Leader Maintenance Course 	<ul style="list-style-type: none"> • 1SG/Commander Course • Joint Firepower Course 	<ul style="list-style-type: none"> • Command Sergeant Major Legal Orientation • Keystone AMF • Pre-Command Course

* Requires a minimum of 18 – 24 months to be considered Career Developmental (KD) complete or 12-month Bradley Commander w/ 12-months Master Gunner experience at current grade.



MOS 19C



The Bradley Crewmember's role on the battlefield is to close with and destroy enemy forces using firepower, mobility, and shock effect. Bradley Crewmembers primarily conduct decisive action in unified land operations.

LEADERSHIP POSITIONS

Most-qualified looks like:

SSG: 24 months as a Bradley Commander **or** 12 months Bradley Commander with 12 Master Gunner experience at current grade with MQ rating, high enumeration, and selected to serve as a Platoon Sergeant or Battalion Master Gunner.

SFC: 24 months as a Platoon Sergeant with MQ rating and high enumeration and selected to serve as a First Sergeant.

Highly qualified looks like:

SSG: 18-24 months as Bradley Commander **or** 12 months Bradley Commander with 12 Master Gunner experience at current grade with HQ rating and mid-level enumeration.

SFC: 18-24 months as Platoon Sergeant with HQ rating and mid-level enumeration.

*Armor Proponent defines bradley commander positions as those within Operating Force, Opposing Force (OPFOR) elements at the National Training Center (NTC), Ft Irwin,

*pending restructure of 19C KD positions within 316th CAV.



U.S. ARMY

MOS 19C



PHYSICAL FITNESS

Most-qualified looks like:

SSG: ACFT Score 540 or above, with a score of 90 in each event, without event substitution and meets AR 600-9 requirements.

SFC: ACFT Score 540 or above, with a score of 90 in each event, without event substitution and meets AR 600-9 requirements.

Highly qualified looks like:

SSG: ACFT Score 480 or above, with a score of 80 in each event, and meets AR 600-9 requirements.

SFC: ACFT Score 480 or above, with a score of 80 in each event, and meets AR 600-9 requirements.

MILITARY/CIVILIAN EDUCATION

Most-qualified looks like:

SSG: Distinguished Honor Graduate or Commandant's List at PME and functional courses and 60 or more college semester hours or a degree.

SFC: Distinguished Honor Graduate or Commandant's List at PME and functional courses and 80 or more college semester hours.

Highly qualified looks like:

SSG: Graduate of the Advanced Leader Course (ALC) with some college.

SFC: Graduate of the Senior Leader Course (SLC) with some college.



U.S. ARMY

MOS 19C



ASSIGNMENTS (Broadening and Generating)

SSG: Instructor, Doctrinal Developer/Writer, Combat Development NCO, AC/RC positions, Drill Sergeant, Assistant Operations Sergeant, Recruiter.

SFC: Talent Manager (HRC), Career Management NCO (OCOA), Operations Sergeant, Assistant Operations Sergeant, Senior Intelligence NCO, Observer Controller Trainer (OC/T), EOA, Inspector General NCO, Senior Drill Sergeant, Senior Instructor, Military Science Instructor (MSI).



U.S. ARMY

MOS 19C



TRAINING

Most-qualified looks like:

SSG: Two or more of the following courses: Bradley Master Gunner, Instructor/Operator Course (I/O Certification), and/or Battle Staff.

SFC: Two or more of the following courses: Bradley Master Gunner, Maneuver Leaders Maintenance Course (MLMC), Instructor/Operator Course (I/O Certification), Cavalry Leader Course (CLC), and/or Battle Staff.

Highly qualified looks like:

SSG: One of the following courses: Bradley Master Gunner, Instructor/Operator Course (I/O Certification), or Battle Staff.

SFC: One of the following courses: Bradley Master Gunner, Maneuver Leaders Maintenance Course (MLMC), Instructor/Operator certified (I/O Certification), Cavalry Leader Course (CLC), or Battle Staff.

OTHER INDICATIONS















Most-qualified looks like:

SSG: Sullivan Cup Best Bradley Crew Competition, Crew/Platoon-level Competitions, SGT Audie Murphy, SGT Morales, Division level NCO Quarter/Year, Distinguished score during gunnery.

SFC: Sullivan Cup Best Bradley Crew Competitions, Crew/Platoon-level Competitions, SGT Audie Murphy, SGT Morales, Division level NCO Quarter/Year. Focused on Platoon level accomplishments.

19D Talent Development Model

Years of Service 2 4 6 8 10 12 14 16 18 20 22 24 26 28 30

<p>Rank Position</p>	 Driver, Gunner, Scout	 Gunner, Team Leader	 Squad / Section Leader	 Platoon Sergeant	 First Sergeant	 BN/BDE CSM
<p>Military Education</p> <p>NCOPDS (earliest opportunities to attend course)</p>						 
<p>Civilian Education Degree Program</p>						
<p>Broadening Opportunities</p> <p>(Not ordered in precedence)</p>	<p>PVT-SPC</p> <p><i>No broadening opportunities exist</i></p>	<p>SGT</p> <p><i>No broadening opportunities exist</i></p>	<p>SSG</p> <ul style="list-style-type: none"> AC/RC OC/T Drill Sergeant Instructor MSI Recruiter SFAB Combat Advisor SGL 	<p>SFC</p> <ul style="list-style-type: none"> AC/RC OC/T CTC OC/T Equal Opportunity Advisor Instructor MSI Senior Drill Sergeant SGL Talent Management NCO Career Management NCO 	<p>MSG</p> <ul style="list-style-type: none"> AC/RC OC/T CTC OC/T Equal Opportunity Advisor Inspector General SR Instructor MSI Senior Career Management NCO Senior Talent Management NCO 	<p>SGM/CSM</p> <ul style="list-style-type: none"> Branch SGM Chief Career Management NCO Chief MSI CSM O/C CST SGM DOTS SGM CH Instructor JMRC CSM USAAC BDE CSM USASMA <ul style="list-style-type: none"> Executive Officer Instructor Training Developer
<p>Functional Courses/Troop Schools</p> <p>(Earliest opportunities to attend courses, not all encompassing)</p>	<p>SPC</p> <ul style="list-style-type: none"> Ranger Course DTMS Environmental Compliance Unit Armorer Airborne Air Assault 	<p>SGT</p> <ul style="list-style-type: none"> BFV Master Gunner Master Driver Safety Unit Prevention Leader HAZMAT Jumpmaster 	<p>SSG</p> <ul style="list-style-type: none"> Scout Leader Course Basic Recruiter Course Battle Staff NCO BFV CDR Course Combat Advisor CFDIC Drill Sergeant Equal Opportunity Master Fitness Master Resiliency Master Driver Unit Movement Officer 	<p>SFC</p> <ul style="list-style-type: none"> Cavalry Leader Course Inspector General Maneuver Leader Maintenance Course 	<p>MSG</p> <ul style="list-style-type: none"> 1SG/Commander Course Joint Firepower Course 	<p>SGM</p> <ul style="list-style-type: none"> Command Sergeant Major Legal Orientation Keystone AMF Pre-Command Course

*Requires a minimum of 18 – 24 months to be considered Career Developmental (KD) complete or 12-month Bradley Commander w/ 12-months Troop Master Gunner experience at current grade.



MOS 19D



The Cavalry Scout serves, leads, or supervises as a member of a scout platoon that conducts reconnaissance and security operations, both mounted and dismounted, to answer the commander's information requirements and provide early warning to the protected force.

LEADERSHIP POSITIONS

Most-qualified looks like:

SSG: 24 months as Squad Leader / Section Leader or 12 months of Squad Leader with 12 months of Master Gunner experience at current grade with MQ rating and high enumeration. Selected to serve as a Platoon Sergeant or Squadron Master Gunner.

SFC: 24 months as Platoon Sergeant with MQ rating and high enumeration. Selected to serve as a First Sergeant.

Highly qualified looks like:

SSG: 18-24 months as Squad Leader / Section Leader or 12 months of Squad Leader with 12 months of Master Gunner experience at current grade with HQ rating and mid-level enumeration. Selected to serve as a Platoon Sergeant or Squadron Master Gunner.

SFC: 18-24 months as Platoon Sergeant with HQ ranking and mid-level enumeration.

*Armor Proponent defines squad leader or section leader positions as those within Operating Force, Opposing Force (OPFOR) elements at the Combat Training Centers (JMRC, JRTC, NTC), or within 1-16th Cavalry Squadron, 316th Cavalry BDE, Fort Benning, GA.



MOS 19D



PHYSICAL FITNESS

Most-qualified looks like:

SSG: ACFT Score 540 or above, with a score of 90 in each event, without event substitution and meets AR 600-9 requirements.

SFC: ACFT Score 540 or above, with a score of 90 in each event, without event substitution and meets AR 600-9 requirements.

Highly qualified looks like:

SSG: ACFT Score 480 or above, with a score of 80 in each event, and meets AR 600-9 requirements.

SFC: ACFT Score 480 or above, with a score of 80 in each event, and meets AR 600-9 requirements.

MILITARY/CIVILIAN EDUCATION

Most-qualified looks like:

SSG: Distinguished Honor Graduate or Commandant's List at PME and functional courses and 60 or more college semester hours or a degree.

SFC: Distinguished Honor Graduate or Commandant's List at PME and functional courses and 80 or more college semester hours.

Highly qualified looks like:

SSG: Graduate of the Advanced Leader Course (ALC) with some college.

SFC: Graduate of the Senior Leader Course (SLC) with some college.



MOS 19D



ASSIGNMENTS (Broadening and Generating)

SSG: Troop Master Gunner, Assistant Operations Sergeant, Drill Sergeant, Recruiter, Instructor, Observer Controller Trainer (OC/T), Combat Development NCO, Training Developer/Writer, SFAB Advise/Assist NCO, EOL, Ranger Instructor.

SFC: Battalion/Squadron Master Gunner, Talent Manager (HRC), Career Management NCO (OCOA), Operations Sergeant, Assistant Operations Sergeant, Senior Intelligence NCO, Observer Controller Trainer (OC/T), EOA, Inspector General NCO, Senior Drill Sergeant, Senior Instructor, Project Warrior, Military Science Instructor (MSI), SFAB Advise/Assist NCO, MATA Instructor, Ranger Instructor.



MOS 19D



TRAINING

Most-qualified looks like:

SSG: Two or more of the following courses: Scout Leader Course (SLC), Bradley MasterGunner, Instructor/Operator Course (I/O certification), Ranger, Jump Master, and/or Battle Staff.

SFC: Cavalry Leaders Course (CLC), Scout Leader Course (SLC), Bradley Master Gunner, Instructor/Operator Course (I/O certification), Ranger, Jump Master, or Battle Staff.

Highly qualified looks like:

SSG: One of the following courses: Scout Leader Course (SLC), Bradley Master Gunner, Instructor/Operator Course (I/O certification), Ranger, Jump Master, and/or Battle Staff.

SFC: One of the following courses: Cavalry Leader Course (CLC), Scout Leader Course (SLC), Bradley Master Gunner, Instructor/Operator Course (I/O certification), Ranger, Jump Master, or Battle Staff.

OTHER INDICATIONS







Most-qualified looks like:

SSG: Gainey Cup Best Scout Squad Competition, Squad/Section/Platoon-level competitions, SGT Audie Murphy, SGT Morales, Division NCO Quarter/Year, Distinguished score during Gunnery.

SFC: Gainey Cup Best Scout Squad Competition, Squad/Section/Platoon-level competitions, SGT Audie Murphy, SGT Morales, Division NCO Quarter/Year. Focused on Platoon level accomplishments.

19K Talent Development Model

Years of Service 2 4 6 8 10 12 14 16 18 20 22 24 26 28 30

<p>Rank Position</p>	 Driver/ Loader	 Gunner	  Tank/MPF Commander Platoon Sergeant Requires a <u>minimum</u> of 18-24 months to be considered KD complete. *See additional note below for SSG.			 First Sergeant	 BN/BDE CSM												
<p>Military Education</p> <p>NCOPDS (earliest opportunities to attend courses)</p>	<div style="display: flex; justify-content: space-around; align-items: center;"> <div style="border: 1px solid black; background-color: #4a86e8; color: white; padding: 5px; margin: 2px;">BLC</div> <div style="border: 1px solid black; background-color: #4a86e8; color: white; padding: 5px; margin: 2px;">ALC</div> <div style="border: 1px solid black; background-color: #4a86e8; color: white; padding: 5px; margin: 2px;">SLC</div> <div style="border: 1px solid black; background-color: #4a86e8; color: white; padding: 5px; margin: 2px;">MLC</div> <div style="border: 1px solid black; background-color: #4a86e8; color: white; padding: 5px; margin: 2px;">SMC</div> <div style="border: 1px solid black; background-color: #4a86e8; color: white; padding: 5px; margin: 2px;">NOM</div> </div>																		
	Associate's Degree		Bachelor's Degree			Master's Degree													
<p>Civilian Education Degree Program</p>	<table border="1" style="width: 100%; border-collapse: collapse;"> <thead> <tr> <th style="width: 16.6%;">PVT-SPC</th> <th style="width: 16.6%;">SGT</th> <th style="width: 16.6%;">SSG</th> <th style="width: 16.6%;">SFC</th> <th style="width: 16.6%;">MSG</th> <th style="width: 16.6%;">SGM/CSM</th> </tr> </thead> <tbody> <tr> <td style="vertical-align: top;"> <p><i>No broadening opportunities exist</i></p> </td> <td style="vertical-align: top;"> <p><i>No broadening opportunities exist</i></p> </td> <td style="vertical-align: top;"> <ul style="list-style-type: none"> AC/RC OC/T Drill Sergeant Instructor MSI Recruiter SGL </td> <td style="vertical-align: top;"> <ul style="list-style-type: none"> AC/RC OC/T CTC OC/T Equal Opportunity Advisor Inspector General Instructor MSI Senior Drill Sergeant SGL Talent Management NCO Career Management NCO </td> <td style="vertical-align: top;"> <ul style="list-style-type: none"> AC/RC OC/T CTC OC/T Equal Opportunity Advisor Inspector General SR Instructor MSI Senior Career Management NCO Senior Talent Management NCO </td> <td style="vertical-align: top;"> <ul style="list-style-type: none"> Branch SGM Chief Career Management NCO Chief MSI CSM O/C CST SGM DOTS SGM CH Instructor JMRC CSM USAAC BDE CSM USASMA <ul style="list-style-type: none"> Executive Officer Instructor Training Developer </td> </tr> </tbody> </table>							PVT-SPC	SGT	SSG	SFC	MSG	SGM/CSM	<p><i>No broadening opportunities exist</i></p>	<p><i>No broadening opportunities exist</i></p>	<ul style="list-style-type: none"> AC/RC OC/T Drill Sergeant Instructor MSI Recruiter SGL 	<ul style="list-style-type: none"> AC/RC OC/T CTC OC/T Equal Opportunity Advisor Inspector General Instructor MSI Senior Drill Sergeant SGL Talent Management NCO Career Management NCO 	<ul style="list-style-type: none"> AC/RC OC/T CTC OC/T Equal Opportunity Advisor Inspector General SR Instructor MSI Senior Career Management NCO Senior Talent Management NCO 	<ul style="list-style-type: none"> Branch SGM Chief Career Management NCO Chief MSI CSM O/C CST SGM DOTS SGM CH Instructor JMRC CSM USAAC BDE CSM USASMA <ul style="list-style-type: none"> Executive Officer Instructor Training Developer
PVT-SPC	SGT	SSG	SFC	MSG	SGM/CSM														
<p><i>No broadening opportunities exist</i></p>	<p><i>No broadening opportunities exist</i></p>	<ul style="list-style-type: none"> AC/RC OC/T Drill Sergeant Instructor MSI Recruiter SGL 	<ul style="list-style-type: none"> AC/RC OC/T CTC OC/T Equal Opportunity Advisor Inspector General Instructor MSI Senior Drill Sergeant SGL Talent Management NCO Career Management NCO 	<ul style="list-style-type: none"> AC/RC OC/T CTC OC/T Equal Opportunity Advisor Inspector General SR Instructor MSI Senior Career Management NCO Senior Talent Management NCO 	<ul style="list-style-type: none"> Branch SGM Chief Career Management NCO Chief MSI CSM O/C CST SGM DOTS SGM CH Instructor JMRC CSM USAAC BDE CSM USASMA <ul style="list-style-type: none"> Executive Officer Instructor Training Developer 														
<p>Broadening Opportunities</p> <p>(Not ordered in precedence)</p>	<table border="1" style="width: 100%; border-collapse: collapse;"> <thead> <tr> <th style="width: 16.6%;">SPC</th> <th style="width: 16.6%;">SGT</th> <th style="width: 16.6%;">SSG</th> <th style="width: 16.6%;">SFC</th> <th style="width: 16.6%;">MSG</th> <th style="width: 16.6%;">SGM</th> </tr> </thead> <tbody> <tr> <td style="vertical-align: top;"> <ul style="list-style-type: none"> DTMS Environmental Compliance Unit Armorer MPF Operations and Maintenance <p>(Earliest opportunities to attend courses, not all encompassing)</p> </td> <td style="vertical-align: top;"> <ul style="list-style-type: none"> Abrams Master Gunner Safety Unit Prevention Leader HAZMAT </td> <td style="vertical-align: top;"> <ul style="list-style-type: none"> Tank Commander Course MPF Commander Course Basic Recruiter Course Battle Staff NCO CFDIC Drill Sergeant Equal Opportunity Master Fitness Master Resiliency Master Driver </td> <td style="vertical-align: top;"> <ul style="list-style-type: none"> Cavalry Leader Course Inspector General Maneuver Leader Maintenance Course </td> <td style="vertical-align: top;"> <ul style="list-style-type: none"> 1SG/Commander Course Joint Firepower Course </td> <td style="vertical-align: top;"> <ul style="list-style-type: none"> Command Sergeant Major Legal Orientation Keystone AMF Pre-Command Course </td> </tr> </tbody> </table>							SPC	SGT	SSG	SFC	MSG	SGM	<ul style="list-style-type: none"> DTMS Environmental Compliance Unit Armorer MPF Operations and Maintenance <p>(Earliest opportunities to attend courses, not all encompassing)</p>	<ul style="list-style-type: none"> Abrams Master Gunner Safety Unit Prevention Leader HAZMAT 	<ul style="list-style-type: none"> Tank Commander Course MPF Commander Course Basic Recruiter Course Battle Staff NCO CFDIC Drill Sergeant Equal Opportunity Master Fitness Master Resiliency Master Driver 	<ul style="list-style-type: none"> Cavalry Leader Course Inspector General Maneuver Leader Maintenance Course 	<ul style="list-style-type: none"> 1SG/Commander Course Joint Firepower Course 	<ul style="list-style-type: none"> Command Sergeant Major Legal Orientation Keystone AMF Pre-Command Course
SPC	SGT	SSG	SFC	MSG	SGM														
<ul style="list-style-type: none"> DTMS Environmental Compliance Unit Armorer MPF Operations and Maintenance <p>(Earliest opportunities to attend courses, not all encompassing)</p>	<ul style="list-style-type: none"> Abrams Master Gunner Safety Unit Prevention Leader HAZMAT 	<ul style="list-style-type: none"> Tank Commander Course MPF Commander Course Basic Recruiter Course Battle Staff NCO CFDIC Drill Sergeant Equal Opportunity Master Fitness Master Resiliency Master Driver 	<ul style="list-style-type: none"> Cavalry Leader Course Inspector General Maneuver Leader Maintenance Course 	<ul style="list-style-type: none"> 1SG/Commander Course Joint Firepower Course 	<ul style="list-style-type: none"> Command Sergeant Major Legal Orientation Keystone AMF Pre-Command Course 														
	<p>*Requires a <u>minimum</u> of 18 – 24 months to be considered Career Developmental (KD) complete <u>or</u> 12-month Tank Commander w/ 12-months Master Gunner experience at current grade.</p>																		



MOS 19K



The Tanker's role on the battlefield is to close with and destroy enemy forces using firepower, mobility, and shock effect. Tankers primarily conduct decisive action in unified land operations.

LEADERSHIP POSITIONS

Most-qualified looks like:

SSG: 24 months as a Tank/MPF Commander or 12 months of Squad Leader with 12 months of Master Gunner experience at current grade with MQ rating and high enumeration. Selected to serve as a Platoon Sergeant or Battalion Master Gunner.

SFC: 24 months as a Platoon Sergeant with MQ rating and high enumeration. Selected to serve as a First Sergeant.

Highly qualified looks like:

SSG: 18-24 months as Tank/MPF Commander or 12 months of Squad Leader with 12 months of Master Gunner experience at current grade with HQ rating and mid-level enumeration.

SFC: 18-24 months as Platoon Sergeant with HQ rating and mid-level enumeration.

*Armor Proponent defines tank commander positions as those within Operating Force, Opposing Force (OPFOR) elements at the Combat Training Centers (JMRC, JRTC, NTC), or within 1-16th Cavalry Squadron, 316th Cavalry BDE, Fort Benning, GA.



U.S. ARMY

MOS 19K



PHYSICAL FITNESS

Most-qualified looks like:

SSG: ACFT Score 540 or above, with a score of 90 in each event, without event substitution and meets AR 600-9 requirements.

SFC: ACFT Score 540 or above, with a score of 90 in each event, without event substitution and meets AR 600-9 requirements.

Highly qualified looks like:

SSG: ACFT Score 480 or above, with a score of 80 in each event, and meets AR 600-9 requirements.

SFC: ACFT Score 480 or above, with a score of 80 in each event, and meets AR 600-9 requirements.

MILITARY/CIVILIAN EDUCATION

Most-qualified looks like:

SSG: Distinguished Honor Graduate or Commandant's List at PME and functional courses and 60 or more college semester hours or a degree.

SFC: Distinguished Honor Graduate or Commandant's List at PME and functional courses and 80 or more college semester hours.

Highly qualified looks like:

SSG: Graduate of the Advanced Leader Course (ALC) with some college.

SFC: Graduate of the Senior Leader Course (SLC) with some college.



MOS 19K



ASSIGNMENTS (Broadening and Generating)

SSG: Instructor, Doctrinal Developer/Writer, Combat Development NCO, AC/RC positions, Drill Sergeant, Assistant Operations Sergeant, Recruiter, EOA.

SFC: Talent Manager (HRC), Career Management NCO (OCOA), Operations Sergeant, Assistant Operations Sergeant, Senior Intelligence NCO, Observer Controller Trainer (OC/T), EOA, Inspector General NCO, Senior Drill Sergeant, Senior Instructor, Military Science Instructor (MSI).



U.S. ARMY

MOS 19K



TRAINING

Most-qualified looks like:

SSG: Two or more of the following courses: Abrams Master Gunner, Instructor/Operator Course (I/O Certification), and/or Battle Staff.

SFC: Two or more of the following courses: Abrams Master Gunner, Maneuver Leaders Maintenance Course (MLMC), Instructor/Operator Course (I/O Certification), Cavalry Leader Course (CLC), and/or Battle Staff.

Highly qualified looks like:

SSG: One of the following courses: Abrams Master Gunner, Instructor/Operator Course (I/O Certification), or Battle Staff.

SFC: One of the following courses: Abrams Master Gunner, Maneuver Leaders Maintenance Course (MLMC), Instructor/Operator Course (I/O Certification), Cavalry Leader Course, or Battle Staff.

OTHER INDICATIONS

Most-qualified looks like:

SSG: Sullivan Cup Best Tank Crew Competition, Tank/Crew/Platoon-level Competitions SGT Audie Murphy, SGT Morales, Division level NCO Quarter/Year, Distinguished score during gunnery.

SFC: Sullivan Cup Best Tank Crew Competitions, Tank/Crew/Platoon-level Competitions, SGT Audie Murphy, SGT Morales, Division level NCO Quarter/Year. Focused on Platoon level accomplishments.



MOS 19Z-MSG/1SG



The Armor MSG/1SG serves as the principal NCO in an Armor Company, Cavalry Troop, or operations staff section in an ABCT, SBCT, IBCT or higher-level organizations.

LEADERSHIP POSITIONS

Most-qualified looks like:

MSG: 24 months as a Company/Troop First Sergeant with MQ rating and high enumeration and selected to serve in a secondary First Sergeant position.

Highly qualified looks like:

MSG: 24 months as First Sergeant with HQ rating and mid-level enumeration.

*Armor Proponent defines Secondary 1SG positions as HHT/HHC, SFAB, and Garrison First Sergeant positions.



MOS 19Z-MSG/1SG



PHYSICAL FITNESS

Most-qualified looks like:

MSG: ACFT Score 540 or above, with a score of 90 in each event, without event substitution and meets AR 600-9 requirements.

Highly qualified looks like:

MSG: ACFT Score 480 or above, with a score of 80 in each event, and meets AR 600-9 requirements.

MILITARY/CIVILIAN EDUCATION

Most-qualified looks like:

MSG: Distinguished Honor Graduate or Commandant's List at PME and functional courses, with completion of a Bachelor's Degree.

Highly qualified looks like:

MSG: Graduate of Master Leaders Course (MLC) with 80-120 college semester hours earned.

ASSIGNMENTS (Broadening and Generating)

MSG: Brigade or higher-level Master Gunner, Senior Talent Manager (HRC), Senior Career Management NCO (OCOA), Battalion or higher Operations Sergeant, ROTC MSI, AC/RC, OC/T, Division or higher-level staff, Inspector General NCO, EOA.



MOS 19Z-MSG/1SG



TRAINING

Most-qualified looks like:

MSG: Two or more of the following courses: Abrams/Bradley Master Gunner, Cavalry Leaders Course (CLC), Joint Fire Power Control and/or Battle.

Highly qualified looks like:

MSG: One of the following courses: Abrams/Bradley Master Gunner, Cavalry Leaders Course (CLC), Joint Fire Power Control, or Battle Staff.

OTHER INDICATORS

Most-qualified looks like:

MSG: Focused on Company/Troop level accomplishments.



CMF 19 Branch DA Pam 600-25 NCO Professional Development Board Brief

Controlled by: AR Proponent, Office Chief of AR
POC: SGM Russell J. Zacherl, 706-545-7725

*The overall classification of this brief is: **UNCLASSIFIED***



CMF 19 COMMONALITIES



KEY DEVELOPMENT POSITIONS

MQ: 24 months with MQ rating and high enumeration. Selected to serve in higher position.

HQ: 18-24 months with HQ rating and mid-level enumeration.

Note: Armor Proponent Requires a *minimum* of 18 – 24 months to be considered Career Developmental (KD) complete or 12-month Bradley Commander w/ 12-months Troop Master Gunner experience at current grade for SSGs.

Note: Armor Proponent defines key development positions for SSGs and SFCs as those within the Operating Force, Opposing Force (OPFOR), and 1-16th Cavalry Squadron, 316th Cavalry BDE Fort Benning, GA

MIL/CIV EDUCATION

MQ: Distinguished Honor Graduate or Commandant's List at PME and functional courses and a college degree.

HQ: Graduate of required PME and some college.

Note: NCOs should strive toward earning a college degree or credentialing. Although education is an important factor enhancing potential value to the Army, comparison of SMs based on civilian education attainments should be viewed as an indicator of individual initiative rather than as a prerequisite for selection as most/highly qualified. College is favorable to set SMs apart from their peers, but is not a requirement for promotion.

PHYSICAL FITNESS

MQ: ACFT score 540 or above, with a score of 90 in each event.

HQ: ACFT score 480 or above, with a score of 80 in each event and meets AR 600-9 requirements.

TRAINING FOR SSG

MQ: Two or more of the following courses

HQ: One of the following courses

- Bradley Master Gunner
- Instructor/Operator Course (I/O Certification)
- Battle Staff

OTHER ASSIGNMENTS FOR SSG

- Company Master Gunner
- Instructor
- Doctrinal Developer/Writer
- Combat Development NCO
- Observer controller/Trainer (OC/T)
- Drill Sergeant
- Recruiter
- Assistant Operations Sergeant

OTHER INDICATORS FOR SSG

- Sullivan/Gainey Cup
- Crew/Platoon level competitions
- SGT Audie Murphy
- SGT Morales
- Division level NCO of the Quarter/Year
- Distinguished Score during Gunnery

TRAINING FOR SFC

MQ: Two or more of the following courses

HQ: One of the following courses

- Tank/Bradley Master Gunner
- Maneuver Leader Maintenance Course
- Instructor/Operator Course (I/O Certificate)
- Cavalry Leader Course (CLC)
- Battle Staff

OTHER ASSIGNMENTS FOR SFC

- Career Management NCO (OCoA)
- Talent Manager (HRC)
- Inspector General NCO
- Military Science Instructor (MSI)
- Project Warrior (PDSI: P4W)
- Observer Controller Trainer (OC/T)
- EOA
- Battalion Master Gunner
- Senior Drill Sergeant
- Senior Instructor
- Operations Sergeant
- Senior Intelligence NCO

OTHER INDICATORS FOR SFC

- Sullivan/Gainey Cup
- Crew/Platoon level competitions
- SGT Audie Murphy
- SGT Morales
- Division level NCO Quarter/Year
- Focused on Platoon level accomplishments