

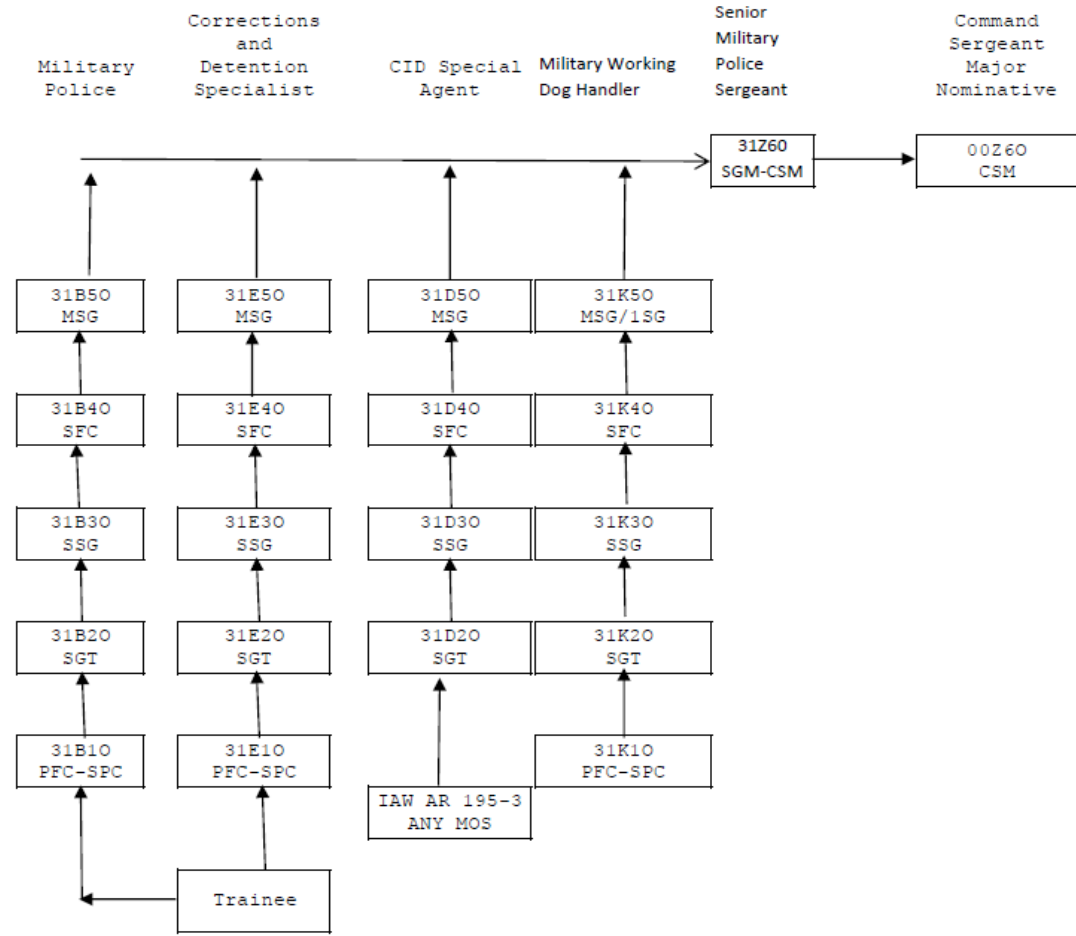

U.S. ARMY

CMF 31 Progression Chart



SUBSTITUTABILITY: None.

→ Line of normal progression.

Figure 10-31. CMF 31 - Military Police career progression (Effective 202010)



U.S. ARMY

31B Talent Development Model (Caps at MSG)

Years of Service	1	3	6	10	14	18
Key Leadership Position <i>(18-30+ MONTHS)</i>	Military Police	Team Leader	Squad Leader	Platoon Sergeant Detachment Sergeant	First Sergeant	
Military/Civilian Education	DLC 1 BLC	DLC 2 ALC	DLC 3 SLC	DLC 4 MLC	DLC 5 SMC	
Critical Development <i>(POST Leadership)</i>		Asst. Squad Leader Plans NCO Training Sergeant MMS NCO	SFAB (Police Advisor) Operations Sergeant PSD NCO MP Investigator NCO Desk Sergeant	Operations NCO PSD NCO	SFAB (Operations NCO) Operations NCO Provost NCO PM Operations NCO	
Broadening Opportunities	Drug Suppression Investigator, MP Investigator, PSD Specialist, Traffic MGMT & Collision Investigator	MP Investigator, PSD NCO	Drill Sergeant, Recruiter, Instructor/Writer, Small Group Leader, Military Science Instructor, Observer Coach/Trainer, Capabilities Division NCO (Futures Command)	Training NCO, System Development Manager, Project NCO	Talent Mgmt NCO, Career MGMT NCO, Tactical NCO, System Development NCO, Training Developer, Senior Training Management NCO, Capability Developer	Senior PDNCO, Inspector General NCO, White House Fellowship, EO Advisor, PSD NCO
Military Training	MP Investigator, Traffic MGMT and Collision Investigator	MP Investigator, Anti-Terrorism Officer (Basic), Conventional Physical Security/Crime Prevention	MP Investigator, Anti-Terrorism Officer (Basic), Conventional Physical Security/Crime Prevention	MP Investigator, Anti-Terrorism Officer (Basic), Conventional Physical Security/Crime Prevention	Law Enforcement Senior Leaders	
		Protective Services Training, Special Reaction Team		Battle Staff NCO, Protective Services Training		
		Senior Enlisted Joint Professional Military Education (1)		Senior Enlisted Joint Professional Military Education (2)		



U.S. ARMY

MOS 31B

Military Police enable maneuver, protect the force, and shape the security environment by conducting police operations, detention and security, and mobility support across the full range of military operations in order to enable protection and promote the rule of law; while at home station, Military Police support garrison law enforcement policing operations to safeguard communities, reduce crime, and preserve good order and discipline.

LEADERSHIP POSITIONS

Most qualified looks like:

SSG: Squad Leader for 30 or more months

SFC: Platoon Sergeant/Detachment Sergeant for 30 or more months

MSG: First Sergeant for a 30 or more months

Highly qualified looks like:

SSG: Squad Leader for 24 to 29 months

SFC: Platoon Sergeant/Detachment Sergeant for 24 to 29 months

MSG: First Sergeant for 24 to 29 months



MOS 31B

PHYSICAL FITNESS

Most qualified looks like:

SSG: 540 on ACFT
SFC: 540 on ACFT
MSG: 540 on ACFT

Highly qualified looks like:

SSG: 510 on ACFT
SFC: 510 on ACFT
MSG: 510 on ACFT

MILITARY/CIVILIAN EDUCATION

Most qualified looks like:

SSG: Associates Degree or 60 credit hours toward a Bachelor Degree, Distinguished Honor Graduate/Leadership Awardee of ALC
SFC: Associate Degree and/or over 90 total credit hours toward Bachelor Degree, Distinguished Honor Graduate/Leadership Awardee of SLC
MSG: Bachelors Degree, Distinguished Honor Graduate/Leadership Awardee of MLC

Highly qualified looks like:

SSG: 30 College credit hours, ALC Commandants List
SFC: Associate Degree and/or over 60 credit hours toward Bachelor Degree, SLC Commandants List
MSG: Associate Degree and/or over 90 total credit hours toward Bachelor Degree, MLC Commandants List



MOS 31B

ASSIGNMENTS (Broadening and Critical Developmental) **PROPONENT SPECIFIC CHALLENGING/HIGH RISK**

SSG: The Broadening assignments for a SSG are Drill Sergeant, Recruiter, Instructor/Writer, Small Group Leader, Military Science Instructor, Observer Coach/Trainer, and Capabilities Division NCO (Futures Command). The Critical Development Assignments for a SSG is SFAB (Police Advisor), Operations Sergeant, PSD NCO, MP Investigator NCO, and Desk Sergeant.

SFC: The Broadening assignments for a SFC are Drill Sergeant, Recruiter, Instructor/Writer, Small Group Leader, Military Science Instructor, Observer Coach/Trainer, Capabilities Division NCO (Futures Command), Talent MGMT NCO, Career Management NCO, Tactical NCO, System Development NCO, Training Developer, Senior Training Management NCO, and Capability Developer. The Critical Developmental Assignments for a SFC is Operations NCO and PSD NCO.

MSG: The Broadening Assignments for a MSG are Senior PDNCO, Inspector General NCO, White House Fellowship, EO Advisor, and PSD NCO. The Critical Developmental Assignments for a MSG is SFAB (Operations NCO), Operations NCO, Provost NCO, and PM Operations NCO.



MOS 31B

TRAINING

Most qualified looks like:

SSG: ALC, DLC II, SEJPME I, Military Police Investigator, Conventional Physical Security/Crime Prevention Course, Protective Services Training

SFC: SLC, DLC III, SEJPME II, Battle Staff Course

MSG: MLC, DLC IV, SEJPME II, Law Enforcement Senior Leaders Course

Highly qualified looks like:

SSG: ALC, DLC II, Traffic Management and Collision Investigator

SFC: SLC, DLC III, Conventional Physical Security/Crime Prevention Course

MSG: MLC, DLC IV

OTHER INDICATORS

Most qualified looks like:

SSG: Expert Soldier Badge, Audie Murphy/SGT Morales member, NCO of the Year/Quarter, Instructor Badge (Basic/Senior/Master), Recruiter Badge (Silver/Gold), Order of the Marechaussee

SFC: Expert Soldier Badge, Audie Murphy/SGT Morales member, NCO of the Year/Quarter, Instructor Badge (Basic/Senior/Master), Recruiter Badge (Silver/Gold), Order of the Marechaussee

MSG: Expert Soldier Badge, Audie Murphy/SGT Morales member, NCO of the Year/Quarter, Instructor Badge (Basic/Senior/Master), Recruiter Badge (Silver/Gold), Order of the Marechaussee



U.S. ARMY

31D Talent Development Model (Caps at MSG)

Years of Service	1	3	6	10	14	18
Key Leadership Position <small>(18-30+ MONTHS)</small>	Special Agent		Special Agent		Detachment Sergeant	
Military/Civilian Education	Associate's Degree		Bachelor's Degree			
Critical Development <small>(POST Leadership)</small>		Criminal Intel NCO Protective Service Agent		Evidence Custodian Protective Service NCO Operations NCO Criminal Intel NCO		Detachment Sergeant Operations Sergeant
Broadening Opportunities		Instructor/Writer, Small Group Leader			Assistant Inspector General, EO Advisor, CID Enlisted Development NCO	
Military Training	Protective Services Training, Child Abuse Prevention Investigative Techniques, Domestic Violence Intervention Training, Special Victim Capability, Advanced Crime Scene Investigative Techniques			Advanced Crime Scene Investigative Techniques		Law Enforcement Senior Leader, Military Police Pre-Command Course
		Crime and Criminal Intelligence Analyst				
	Senior Enlisted Joint Professional Military Education (1)			Senior Enlisted Joint Professional Military Education (2)		

DLC 2

ALC

DLC 3

SLC

DLC 4

MLC

DLC 5

SMC



U.S. ARMY

MOS 31D

The CID Special Agent supervises or conducts investigations of incidents and offenses or allegations of criminality affecting DA or DoD personnel, property, facilities, or activities.

LEADERSHIP POSITIONS

Most qualified looks like:

SSG: Special Agent for 30 or more months

SFC: Detachment Sergeant for 30 or more months

MSG: First Sergeant for 30 or more months

Highly qualified looks like:

SSG: Special Agent for 24 to 29 months

SFC: Detachment Sergeant for 24 to 29 months

MSG: First Sergeant for 24 to 29 months



MOS 31D

PHYSICAL FITNESS

Most qualified looks like:

- SSG: 540 on ACFT
- SFC: 540 on ACFT
- MSG: 540 on ACFT

Highly qualified looks like:

- SSG: 510 on ACFT
- SFC: 510 on ACFT
- MSG: 510 on ACFT

MILITARY/CIVILIAN EDUCATION

Most qualified looks like:

- SSG: Associates Degree and 90 credit hours toward a Bachelor Degree Distinguished Honor Graduate/Leadership Awardee of ALC
- SFC: Associates Degree and 105 credit hours toward a Bachelor Degree, Distinguished Honor Graduate/Leadership Awardee of SLC
- MSG: Bachelors Degree, Distinguished Honor Graduate/Leadership Awardee of MLC

Highly qualified looks like:

- SSG: Associates Degree and 75 credit hours toward a Bachelor Degree, ALC Commandants List
- SFC: Associates Degree and 90 credit hours toward a Bachelor Degree, SLC Commandants List
- MSG: Associates Degree and 105 credit hours toward a Bachelor Degree MLC Commandants List



MOS 31D

ASSIGNMENTS (Broadening and Critical Developmental)
PROPONENT SPECIFIC CHALLENGING/HIGH RISK

SSG: The Broadening assignments for a Small Group Leader and Instructor/Writer. The Critical Developmental Assignments for a SSG is Criminal Intel NCO and Protective Service Agent.

SFC: The Broadening assignments for a SFC are Small Group Leader, Instructor/Writer, Talent MGMT NCO, Training Developer, System Development NCO, and Inspector General NCO. The Critical Developmental Assignments for a SFC is Evidence Custodian, Protective Service NCO, Operations NCO, and Criminal Intel NCO.

MSG: The Broadening Assignments for a MSG are Assistant Inspector General, EO Advisor, and CID Enlisted Development NCO. The Critical Developmental Assignments for a MSG is Detachment Sergeant and Operations Sergeant.



MOS 31D

TRAINING

Most qualified looks like:

SSG: ALC, DLC II, SEJPME I, Protective Services Training

SFC: SLC, DLC III, SEJPME II, Crime and Criminal Analyst Course

MSG: MLC, DLC IV, SEJPME II, Law Enforcement Senior Leaders Course

Highly Qualified looks like:

SSG: ALC, DLC II, Domestic Violence Intervention Training

SFC: SLC, DLC III, Child Abuse Prevention Investigative Techniques

MSG: MLC, DLC IV, Advanced Crime Scene Investigation Techniques Course

OTHER INDICATORS

Most qualified looks like:

SSG: Expert Soldier Badge, Audie Murphy/SGT Morales member, NCO of the Year/Quarter, Instructor Badge (Basic/Senior/Master), Order of the Marechausee

SFC: Expert Soldier Badge, Audie Murphy/SGT Morales member, NCO of the Year/Quarter, Instructor Badge (Basic/Senior/Master), Order of the Marechausee

MSG: Expert Soldier Badge, Audie Murphy/SGT Morales member, NCO of the Year/Quarter, Instructor Badge (Basic/Senior/Master), Order of the Marechausee

31E Talent Development Model (Caps at MSG)



Years of Service	1	3	6	10	14	18
Key Leadership Position <i>(18-30+ MONTHS)</i>	C/D Specialist	Team Leader	Squad Leader	Platoon Sergeant	First Sergeant	
Military/Civilian Education	DLC 1 BLC	DLC 2 ALC	DLC 3 SLC	DLC 4 MLC	DLC 5 SMC	
Critical Development <i>(POST Leadership)</i>		C/D NCO	Operations NCO Special Housing Unit Shift Leader	Watch Commander Operations NCO Special Housing Unit NCOIC	Watch Commander ACC Ops/ Trng NCO	
Broadening Opportunities	MP Investigator	MP Investigator, Housing Unit NCO	Drill Sergeant, Instructor, Small Group Leader, Observer Coach/Trainer	Corrections Supervisor, Corrections Liaison, MP Investigator Supervisor, Housing Unit NCOIC, ACA Plans and Policy NCO, Project Supervisor	Talent Mgmt NCO, Training Developer, System Development NCO, Prisoner Services/Admin NCO, Corrections Supervisor, Plans NCO	Senior Career Management NCO, Inspector General NCO, Training with Industry, BN/BDE Operations
Military Training	MP Investigator, Special Reaction Team		Anti-Terrorism Officer (Basic)	Conv Physical Security/Crime Prevention	Battle Staff NCO, Anti-Terrorism Officer (Advanced)	Law Enforcement Senior Leaders
		Senior Enlisted Joint Professional Military Education (1)			Senior Enlisted Joint Professional Military Education (2)	



U.S. ARMY

MOS 31E

The Correction/Detention (C/D) Specialist in CONUS operations provides exemplarily custody and control of U.S. military inmates located at the two Regional Correctional Facilities and the United States Disciplinary Barracks; OCONUS, C/D Specialists delivers humane, legal, and thorough detainee operations at an unparalleled level of expertise to all overseas contingency operations.

LEADERSHIP POSITIONS

Most qualified looks like:

SSG: Squad Leader for 30 or more months

SFC: Platoon Sergeant or Detachment Sergeant for 30 or more months

MSG: First Sergeant for 30 or more months

Highly qualified looks like:

SSG: Squad Leader for 24 to 29 months

SFC: Platoon Sergeant or Detachment Sergeant for 24 to 29 months

MSG: First Sergeant for 24 to 29 months



MOS 31E

PHYSICAL FITNESS

Most qualified looks like:

SSG: 540 on ACFT
SFC: 540 on ACFT
MSG: 540 on ACFT

Highly qualified looks like:

SSG: 510 on ACFT
SFC: 510 on ACFT
MSG: 510 on ACFT

MILITARY/CIVILIAN EDUCATION

Most qualified looks like:

SSG: Associates Degree or 60 credit hours toward a Bachelor Degree, Distinguished Honor Graduate/Leadership Awardee of ALC
SFC: Associate Degree and/or over 90 total credit hours toward Bachelor Degree, Distinguished Honor Graduate/Leadership Awardee of SLC
MSG: Bachelors Degree, Distinguished Honor Graduate/Leadership Awardee of MLC

Highly qualified looks like:

SSG: 30 College credit hours, ALC Commandants List
SFC: Associate Degree and/or over 60 credit hours toward Bachelor Degree, SLC Commandants List
MSG: Associate Degree and/or over 90 total credit hours toward Bachelor Degree, MLC Commandants List



MOS 31E

ASSIGNMENTS (Broadening and Critical Developmental) **PROPONENT SPECIFIC CHALLENGING/HIGH RISK**

SSG: The Broadening assignments for a SSG are Drill Sergeant, Instructor, Small Group Leader, Observer Coach/Trainer, Corrections Supervisor, Corrections Liaison, MP Investigator Supervisor, Housing Unit NCOIC, ACA Plans and Policy NCO, and Project Supervisor. The Critical Developmental Assignments for a SSG is Operations NCO and Special Housing Unit Shift Leader.

SFC: The Broadening assignments for a SFC are Drill Sergeant, Instructor, Small Group Leader, Observer Coach/Trainer, Talent MGMT NCO, Training Developer, System Development NCO, Prisoner Services/Admin NCO, Corrections Supervisor, and Plans NCO. The Critical Developmental Assignments for a SFC is Watch Commander, Operations NCO, and Special Housing Unit NCOIC.

MSG: The Broadening Assignments for a MSG are Senior Career Management NCO, Inspector General NCO, Training with Industry, and BN/BDE Operations. The Critical Developmental Assignments for a MSG is Watch Commander and ACC Ops/Trng NCO.



MOS 31E

TRAINING

Most qualified looks like:

SSG: ALC, DLC II, SEJPME I, Anti-Terrorism Officer (Advanced) Course

SFC: SLC, DLC III, SEJPME II, Battle Staff Course

MSG: MLC, DLC IV, SEJPME II, Law Enforcement Senior Leaders Course

Highly Qualified looks like:

SSG: ALC, DLC II, Special Reaction Team

SFC: SLC, DLC III, Conventional Physical Security/Crime Prevention Course

MSG: MLC, DLC IV

OTHER INDICATORS

Most qualified looks like:

SSG: Expert Soldier Badge, Audie Murphy/SGT Morales member, NCO of the Year/Quarter, Instructor Badge (Basic/Senior/Master), Recruiter Badge (Silver/Gold), Order of the Marechaussee

SFC: Expert Soldier Badge, Audie Murphy/SGT Morales member, NCO of the Year/Quarter, Instructor Badge (Basic/Senior/Master), Recruiter Badge (Silver/Gold), Order of the Marechaussee

MSG: Expert Soldier Badge, Audie Murphy/SGT Morales member, NCO of the Year/Quarter, Instructor Badge (Basic/Senior/Master), Recruiter Badge (Silver/Gold), Order of the Marechaussee

31K Talent Development Model (Caps at MSG)



U.S. ARMY

Years of Service

1





3

6

10

14

18

					
Key Leadership Position <i>(18-30+ MONTHS)</i>	MWD Handler	Team Leader	Squad Leader	Kennel Master	First Sergeant MWD Program Manager
Military/Civilian Education	DLC 1 BLC	DLC 2 ALC	DLC 3 SLC	DLC 4 MLC	DLC 5 SMC
Critical Development <i>(POST Leadership)</i>			MWD Plans NCO Operations NCO	Operations NCO BDE MWD Program Manager	MWD Course Manager
Broadening Opportunities	MWD Trainer			Drill Sergeant, Instructor, Small Group Leader	MWD Career MGMT NCO, Training Development System NCO (MWD), Senior Training Developer
Military Training	Hazardous Materials Course (Driving and Handling)	Technical Transportation of Hazmat, Basic Instructors Course (USAF)	MWD Trainer/Kennel Master Course, Anti-Terrorism Officer (Basic), Conventional Physical Security/Crime Prevention		Capabilities Development Course, Law Enforcement Senior Leaders
	Patrol Explosive Detection Dog Enhanced (PEDD-E)		Battle Staff NCO		
	Senior Enlisted Joint Professional Military Education (1)			Senior Enlisted Joint Professional Military Education (2)	



MOS 31K

Military Working Dog (MWD) teams support joint forces in offensive, defensive, and stability tasks, contributes to the preservation of combat power, and enable the security environment on the battlefield and at post/camp/station; while Patrol Drug Detector Dog (PDDD), Patrol Explosive Detector Dog (PEDD), and Patrol Explosive Detector Dog – Enhanced (PEDD-E) teams provide installation and maneuver commanders the ability to detect and locate hidden personnel, illicit drugs and paraphernalia, weapons, ammunition, explosive ordnance, and improvised explosive devices (IED).

LEADERSHIP POSITIONS

Most qualified looks like:

- SSG: Squad Leader for 30 or more months
- SFC: Kennel Master for 30 or more months
- MSG: First Sergeant or MWD Program Manager for 30 or more months

Highly qualified looks like:

- SSG: Squad Leader for 24 to 29 months
- SFC: Kennel Master for 24 to 29 months
- MSG: First Sergeant or MWD Program Manager for 24 to 29 months



MOS 31K

PHYSICAL FITNESS

Most qualified looks like:

SSG: 540 on ACFT
SFC: 540 on ACFT
MSG: 540 on ACFT

Highly qualified looks like:

SSG: 510 on ACFT
SFC: 510 on ACFT
MSG: 510 on ACFT

MILITARY/CIVILIAN EDUCATION

Most qualified looks like:

SSG: Associates Degree or 60 credit hours toward a Bachelor Degree, Distinguished Honor Graduate/Leadership Awardee of ALC
SFC: Associate Degree and/or over 90 total credit hours toward Bachelor Degree, Distinguished Honor Graduate/Leadership Awardee of SLC
MSG: Bachelors Degree, Distinguished Honor Graduate/Leadership Awardee of MLC

Highly qualified looks like:

SSG: 30 College credit hours, ALC Commandants List
SFC: Associate Degree and/or over 60 credit hours toward Bachelor Degree, SLC Commandants List
MSG: Associate Degree and/or over 90 total credit hours toward Bachelor Degree, MLC Commandants List



MOS 31K

ASSIGNMENTS (Broadening and Critical Developmental) **PROPONENT SPECIFIC CHALLENGING/HIGH RISK**

SSG: The Broadening assignments for a SSG are Drill Sergeant, Instructor, Small Group Leader, MWD Trainer, and MWD Handler Observer Coach/Trainer. The Critical Developmental Assignments for a SSG is MWD Plans NCO and Operations NCO.

SFC: The Broadening assignments for a SFC are Drill Sergeant, Instructor, Small Group Leader, MWD Trainer, Talent MGMT NCO, Senior Training MGMT NCO (MWD), and Multi-Purpose Canine Program Manager. The Critical Developmental Assignments for a SFC is Operations NCO and BDE MWD Program Manager.

MSG: The Broadening Assignments for a MSG are MWD Career Management NCO, Training Development System NCO (MWD), and Senior Training Developer. The Critical Developmental Assignment for a MSG is MWD Course Manager.



U.S. ARMY

MOS 31K

TRAINING

Most qualified looks like:

SSG: ALC, DLC II, SEJPME I, MWD Trainer/Kennel Master Course

SFC: SLC, DLC III, SEJPME II, Battle Staff, MWD Trainer/Kennel Master Course

MSG: MLC, DLC IV, SEJPME II, Capabilities Development Course

Highly Qualified looks like:

SSG: ALC, DLC II, Anti Terrorism Officer (Basic) Course

SFC: SLC, DLC III, Conventional Physical Security/Crime Prevention Course

MSG: MLC, DLC IV, Law Enforcement Senior Leaders Course

OTHER INDICATORS

Most qualified looks like:

SSG: Expert Soldier Badge, Audie Murphy/SGT Morales member, NCO of the Year/Quarter, Instructor Badge (Basic Senior/Master), Order of the Marechausee

SFC: Expert Soldier Badge, Audie Murphy/SGT Morales member, NCO of the Year/Quarter, Instructor Badge (Basic/Senior/Master), Order of the Marechausee

MSG: Expert Soldier Badge, Audie Murphy/SGT Morales member, NCO of the Year/Quarter, Instructor Badge (Basic/Senior/Master), Order of the Marechausee



U.S. ARMY

MOS 31Z

	YEARS POST UNITED STATES ARMY SERGEANTS MAJOR ACADEMY GRADUATION						
	1	2	3	4	5	6	
Key Leadership Position <i>(24-36 months)</i>	Battalion Command Sergeant Major		Brigade/Group Command Sergeant Major			Nominative Command Sergeant Major	
Military/Civilian Education	<div style="background-color: yellow; padding: 5px; text-align: center;">Distributed Leaders Course 6</div> <div style="background-color: lightblue; padding: 5px; text-align: center;">Bachelor's Degree</div>				<div style="background-color: green; padding: 5px; text-align: center;">Nominative Leader Course</div> <div style="background-color: lightblue; padding: 5px; text-align: center;">Master's Degree</div>		
Critical Development <i>(POST Leadership)</i>	Battalion Operations SGM Facility SGM Directorate of Emergency Services		Brigade/Group Operations SGM Chief Career Management NCO G2/G3 SGM (CID HQ) Military District of Washington Provost SGM Provost NCO (TRADOC/FORSCOM/IMCOM/USAREUR-AF/USARPAC)			Army Provost SGM USAMPS/MP Corps CSM HQ USACIDC/CID CSM	
Broadening Opportunities	<div style="background-color: yellow; padding: 5px;"> Directorate of Training and Education (USAMPS) SGM Directorate of Plans and Operations (USAMPS) SGM Basic Military Police Training Division (USAMPS) SGM Non-Commissioned Officer Academy Assistant Commandant (MCSOE) </div>		<div style="background-color: yellow; padding: 5px;"> Observer-Coach CSM (2x BN CSM OCT) Enlisted Military Police Branch SGM Military Working Dog Program SGM United States Army Sergeants Major Academy Fellowship United States Army Sergeants Major Academy Small Group Leader </div>			<div style="background-color: yellow; padding: 5px;"> MSCoE CSM Army Univeristy CSM Senior Staff SGM (G-3) </div>	
Military Training	<div style="background-color: lightgreen; padding: 5px; text-align: center;"> Military Police Pre-Command Course Law Enforcement Senior Leaders Course </div>				<div style="background-color: lightgreen; padding: 5px; text-align: center;"> Senior Leaders Seminar, Keystone Course </div>		



U.S. ARMY

MOS 31Z

Senior Military Police Sergeant is responsible for supervising the manning, training, equipping and combat readiness of a Battalion and Brigade/Group level of command; principle staff NCO in operations whom plans, coordinates and manages Battalion and Brigade operations, training and tasking's to provide Police Operations; Corrections and Detention, Security and Mobility support and Criminal Investigations.

LEADERSHIP POSITIONS

Most qualified looks like:

SGM/CSM: CSM for 30 to 36 month period

Highly qualified looks like:

SGM/CSM: CSM for 24 to 30 months



U.S. ARMY

MOS 31Z

PHYSICAL FITNESS

Most qualified looks like:

SGM/CSM: 540 on ACFT

Highly qualified looks like:

SGM/CSM: 510 on ACFT

MILITARY/CIVILIAN EDUCATION

Most qualified looks like:

SGM/CSM: Master Degree, Distinguished Honor Graduate/Leadership Awardee of USASMA

Highly qualified looks like:

SGM/CSM: Bachelors Degree, USASMA Commandants List



MOS 31Z

ASSIGNMENTS (Broadening and Critical Developmental) **PROONENT SPECIFIC CHALLENGING/HIGH RISK**

SGM/CSM: The Key Leadership Assignment for a 31Z is Battalion/Brigade/Group CSM and should serve in the position for a minimum for 30 months. Key Developmental Assignment for a 31Z is Battalion/Brigade/Group Operations Sergeant Major, Facility SGM, DES SGM, Chief Career Management NCO, G2/G3 Sergeant Major at CID Headquarters, MDW Provost SGM, and TRADOC/FORSCOM/IMCOM/USAREUR-AF/USARPAC Provost NCO. Broadening assignments for a SGM/CSM is Directorate of Training (USAMPS) SGM, Directorate of Plans and Operations (USAMPS) SGM, Basic Military Police Training Division (USAMPS) SGM, NCOA Assistant Commandant (MSCOE), Observer-Coach CSM (2x BN CSM OCT), Enlisted MP Branch SGM, Military Working Dog Program SGM, USASMA Small Group Leader, and USASMA Fellowship positions and should serve in the position for 24 months.



U.S. ARMY

MOS 31Z

TRAINING

Most qualified looks like:

SGM/CSM: DLC VI, Law Enforcement Senior Leaders Course,

Highly Qualified looks like:

SGM/CSM: Military Police Pre-Command Course

OTHER INDICATORS

Most qualified looks like:

SGM/CSM: Audie Murphy/SGT Morales member and Order of the Marechausee