

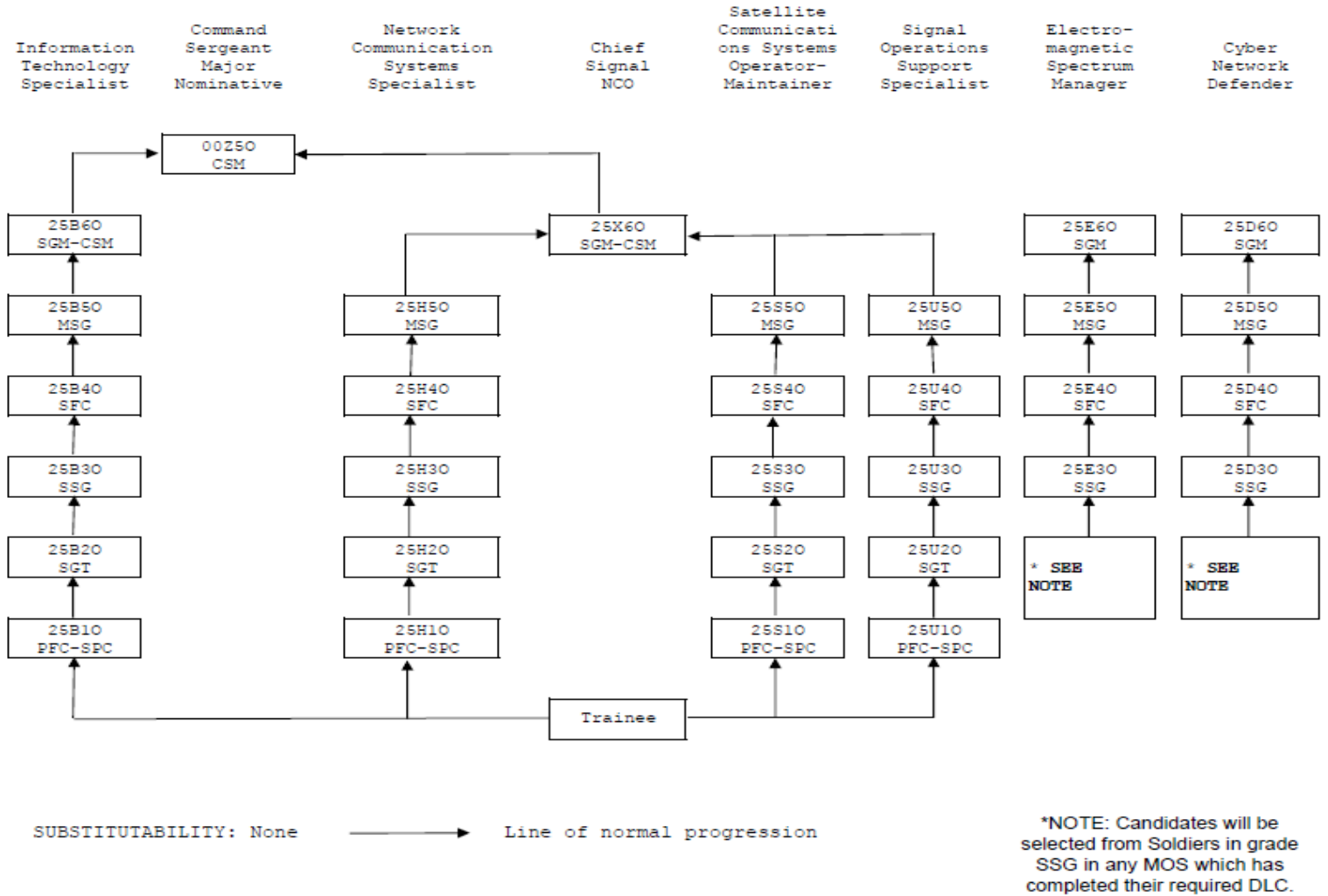

CMF 25 Progression Chart



Effective 202210

Figure 10-25a. CMF 25--Communication and Information Systems career progression



U.S. ARMY

25B Talent Development Model

Years of Service	2	4	6	8	10	12	14	16	18	20	22	24	26	28	30
Key Leadership Position <small>MQ rating and highly numerated ranking</small>	Info Tech Specialist	Senior Info Tech Specialist	Info Tech Team Chief	Info Tech Team Chief	Detachment Sergeant	Detachment Sergeant	Detachment Sergeant	Detachment Sergeant	First Sergeant	First Sergeant	Senior Information Technology Chief	Senior Information Technology Chief	Senior Information Technology Chief	Senior Information Technology Chief	BN/BDE/NOM CSM
Military/Civilian Education	DLC 1 BLC Start College IAT LVL I Certs	DLC 2 ALC 30+ Credit Hours IAT LVL II / IAM LVL I Certs	DLC 3 SLC Associate Degree IAT LVL II-III / IAM LVL I-II Certs	DLC 3 SLC Associate Degree IAT LVL II-III / IAM LVL I-II Certs	DLC 4 MLC Associate Degree IAT LVL II-III / IAM LVL I-II Certs	DLC 4 MLC Associate Degree IAT LVL II-III / IAM LVL I-II Certs	DLC 4 MLC Associate Degree IAT LVL II-III / IAM LVL I-II Certs	DLC 4 MLC Associate Degree IAT LVL II-III / IAM LVL I-II Certs	DLC 5 SGM-A Bachelor's Degree IAT LVL III / IAM LVL II-III Certs	DLC 5 SGM-A Bachelor's Degree IAT LVL III / IAM LVL II-III Certs	DLC 5 SGM-A Bachelor's Degree IAT LVL III / IAM LVL II-III Certs	DLC 6 Nom Master's Degree IAM LVL III Certs	DLC 6 Nom Master's Degree IAM LVL III Certs	DLC 6 Nom Master's Degree IAM LVL III Certs	DLC 6 Nom Master's Degree IAM LVL III Certs
Critical Development		Senior Info Tech Specialist GCC/ASCC IT Specialist	Senior Info Tech Specialist GCC/ASCC IT Specialist	Info Tech Team Chief Info Tech NCO GCC/ASCC IT NCO	Info Tech Team Chief Info Tech NCO GCC/ASCC IT NCO	Info Tech Security MGR Info Tech Supervisor Info Tech Staff NCO	Info Tech Security MGR Info Tech Supervisor Info Tech Staff NCO	Info Tech Security MGR Info Tech Supervisor Info Tech Staff NCO	Info Tech Chief	Info Tech Chief	Info Tech Chief	Senior Information Technology Chief Chief Signal NCO	Senior Information Technology Chief Chief Signal NCO	Senior Information Technology Chief Chief Signal NCO	Senior Information Technology Chief Chief Signal NCO
Broadening Opportunities	Security Force Assistance Brigade (SFAB) Nuclear Surety Info Tech Specialist	Instructor/Writer, ALC Small Group Leader (SGL), Recruiter, Drill Sergeant, Defense Information Systems Agency (DISA), White House Communications Agency (WHCA), Security Force Assistance Brigades (SFABs), Joint Communications Support Element (JCSE), Special Missions Unit (SMU), Nuclear Surety ALT COMSEC ACCT MGR, Training With Industry(TWI)	Instructor/Writer, ALC Small Group Leader (SGL), Recruiter, Drill Sergeant, Defense Information Systems Agency (DISA), White House Communications Agency (WHCA), Security Force Assistance Brigades (SFABs), Joint Communications Support Element (JCSE), Special Missions Unit (SMU), Nuclear Surety ALT COMSEC ACCT MGR, Training With Industry(TWI)	Instructor/Writer, ALC Small Group Leader (SGL), Recruiter, Drill Sergeant, Defense Information Systems Agency (DISA), White House Communications Agency (WHCA), Security Force Assistance Brigades (SFABs), Joint Communications Support Element (JCSE), Special Missions Unit (SMU), Nuclear Surety ALT COMSEC ACCT MGR, Training With Industry(TWI)	Instructor/Writer, ALC Small Group Leader (SGL), Recruiter, Drill Sergeant, Defense Information Systems Agency (DISA), White House Communications Agency (WHCA), Security Force Assistance Brigades (SFABs), Joint Communications Support Element (JCSE), Special Missions Unit (SMU), Nuclear Surety ALT COMSEC ACCT MGR, Training With Industry(TWI)	Defense Information Systems Agency (DISA), White House Communications Agency (WHCA), Training With Industry (TWI), Joint Communication Unit (JCU), Military Equal Opportunity Advisor (MEO Advisor), Sexual Assault Response Coordinator/Victim Advocate (SARC/VA), Special Missions Unit (SMU)	Defense Information Systems Agency (DISA), White House Communications Agency (WHCA), Training With Industry (TWI), Joint Communication Unit (JCU), Military Equal Opportunity Advisor (MEO Advisor), Sexual Assault Response Coordinator/Victim Advocate (SARC/VA), Special Missions Unit (SMU)	Defense Information Systems Agency (DISA), White House Communications Agency (WHCA), Training With Industry (TWI), Joint Communication Unit (JCU), Military Equal Opportunity Advisor (MEO Advisor), Sexual Assault Response Coordinator/Victim Advocate (SARC/VA), Special Missions Unit (SMU)	Sr. Career Management NCO, SR Talent Management NCO, Assistant Commandant, White House Communications Agency (WHCA), NATO, Military Equal Opportunity Advisor (MEO Advisor)	Sr. Career Management NCO, SR Talent Management NCO, Assistant Commandant, White House Communications Agency (WHCA), NATO, Military Equal Opportunity Advisor (MEO Advisor)	Sr. Career Management NCO, SR Talent Management NCO, Assistant Commandant, White House Communications Agency (WHCA), NATO, Military Equal Opportunity Advisor (MEO Advisor)	Signal Proponent SGM, USASMA Fellowship, Program Human Resources Command (HRC)	Signal Proponent SGM, USASMA Fellowship, Program Human Resources Command (HRC)	Signal Proponent SGM, USASMA Fellowship, Program Human Resources Command (HRC)	Signal Proponent SGM, USASMA Fellowship, Program Human Resources Command (HRC)
Military Training	Air Assault Airborne IAT LVL I Certs	Air Assault, Ranger, Airborne, Jumpster, Marksmanship Master Trainer, Master Resilience Trainer, Signal Digital Master Gunner, Management Client Course, Master Fitness Trainer, SEJPME – I	Air Assault, Ranger, Airborne, Jumpster, Marksmanship Master Trainer, Master Resilience Trainer, Signal Digital Master Gunner, Management Client Course, Master Fitness Trainer, SEJPME – I	Air Assault, Ranger, Airborne, Jumpster, Marksmanship Master Trainer, Master Resilience Trainer, Signal Digital Master Gunner, Management Client Course, Master Fitness Trainer, SEJPME – I	Air Assault, Ranger, Airborne, Jumpster, Marksmanship Master Trainer, Master Resilience Trainer, Signal Digital Master Gunner, Management Client Course, Master Fitness Trainer, SEJPME – I	Air Assault, Ranger, Airborne, Jumpster, Marksmanship Master Trainer, Master Resilience Trainer, Signal Digital Master Gunner, Management Client Course, Master Fitness Trainer, SEJPME – II, Joint C4 Planner Course, Battle Staff NCO	Air Assault, Ranger, Airborne, Jumpster, Marksmanship Master Trainer, Master Resilience Trainer, Signal Digital Master Gunner, Management Client Course, Master Fitness Trainer, SEJPME – II, Joint C4 Planner Course, Battle Staff NCO	Air Assault, Ranger, Airborne, Jumpster, Marksmanship Master Trainer, Master Resilience Trainer, Signal Digital Master Gunner, Management Client Course, Master Fitness Trainer, SEJPME – II, Joint C4 Planner Course, Battle Staff NCO	Air Assault, Ranger, Airborne, Jumpster, Master Fitness Trainer, Master Resilience Trainer, Signal Digital Master Gunner, SEJPME – II, Joint C4 Planner Course, Battle Staff NCO	Air Assault, Ranger, Airborne, Jumpster, Master Fitness Trainer, Master Resilience Trainer, Signal Digital Master Gunner, SEJPME – II, Joint C4 Planner Course, Battle Staff NCO	Air Assault, Ranger, Airborne, Jumpster, Master Fitness Trainer, Master Resilience Trainer, Signal Digital Master Gunner, SEJPME – II, Joint C4 Planner Course, Battle Staff NCO	Air Assault, Master Fitness Trainer, Signal Digital Master Gunner, SEJPME – II, Joint C4 Planner Course, Battle Staff NCO, Keystone Course, CSM Legal Orientation Course, Nominative Leader Course	Air Assault, Master Fitness Trainer, Signal Digital Master Gunner, SEJPME – II, Joint C4 Planner Course, Battle Staff NCO, Keystone Course, CSM Legal Orientation Course, Nominative Leader Course	Air Assault, Master Fitness Trainer, Signal Digital Master Gunner, SEJPME – II, Joint C4 Planner Course, Battle Staff NCO, Keystone Course, CSM Legal Orientation Course, Nominative Leader Course	Air Assault, Master Fitness Trainer, Signal Digital Master Gunner, SEJPME – II, Joint C4 Planner Course, Battle Staff NCO, Keystone Course, CSM Legal Orientation Course, Nominative Leader Course



MOS 25B

The Information Technology Specialist plans and supervises the deployment, installation, operation and maintenance of computer systems and the IT network and provides support for the network environment in unclassified and classified networks for operations at all echelons to include Joint organizations. Additionally, the Information Technology Specialist performs Communications Security (COMSEC) Account Management, IAW AR 380-40.

LEADERSHIP POSITIONS

Most qualified looks like:

- SSG: Info Tech Chief for 24 or more months
- SFC: Detachment Sergeant for 24 or more months
- MSG: First Sergeant for 24 or more months
- CSM: Command Sergeant Major for 24 months or more

Highly qualified looks like:

- SSG: Info Tech Chief for 18 to 24 months
- SFC: Detachment Sergeant for 18 to 24 months
- MSG: First Sergeant for 18 to 24 months
- CSM: Command Sergeant Major for 18 months or more



MOS 25B

PHYSICAL FITNESS

Most qualified looks like:

SSG: 540 on ACFT

SFC: 540 on ACFT

MSG: 540 on ACFT

SGM/CSM: 540 on ACFT

Highly qualified looks like:

SSG: 510 on ACFT

SFC: 510 on ACFT

MSG: 510 on ACFT

SGM/CSM: 510 on ACFT

MILITARY/CIVILIAN EDUCATION/CERTIFICATIONS

Most qualified looks like:

SSG: ALC Distinguished Honor Grad/Honor Grad; 30+ Credit hours; Information Assurance Technician Level II / Information Assurance Management Level I cert, Cisco Certified Network Associate, Certified Wireless Network Administrator

SFC: SLC Distinguished Honor Grad/Honor Grad; Associates's Degree; Information Assurance Technician Level III / Information Assurance Management Level II cert, Certified Ethical Hacker, Cisco Certified Network Professional, Microsoft Certified Solutions Associate

MSG: MLC Distinguished Honor Grad/Honor Grad; Bachelor's Degree; Information Assurance Technician Level III /Information Assurance Management Level III cert, Certified Information Systems Security Professional, Certified Information Systems Auditor, Microsoft Certified Solutions Associate, AWS Certified Cloud Practitioner

SGM: Distinguished Honor Grad/Honor Grad; Master's Degree; Information Assurance Management Level III, Certified Information Systems Security Professional, Certified Information Security Manager, Certified Chief Information Security Officer, Microsoft Certified Solutions Associate, AWS Certified Cloud Practitioner

Highly qualified looks like:

SSG: Commandant List; 20+ semester hours of College; Information Assurance Technician Level II

SFC: Commandant List; 30+ semester hours ; Information Assurance Technician Level II /Information Assurance Management Level I

MSG: Commandant List; Associate College; Information Assurance Technician Level II /Information Assurance Management Level I-II

SGM: Commandant List; Bachelor's Degree; Information Assurance Technician Level II-III /Information Assurance Management Level II



MOS 25B

ASSIGNMENTS (Broadening and Critical Developmental)

PROPONENT SPECIFIC CHALLENGING/HIGH RISK

SSG Broadening Assignments are: Drill Sergeant, Recruiter, Instructor/Writer, Nuclear Surety COMSEC Account Manager, Small Group Leader (ALC), Special Mission Unit, White House Communication Agency, Defense Information Systems Agency, Security Forces Assistance Brigade (SFAB), Joint Communication Unit, Joint Communications Support Element. Critical Development assignments are: **Info Tech Security MGR, Info Tech Supervisor, Info Tech Staff NCO.**

SFC Broadening Assignments are: Drill Sergeant, Recruiter, Instructor/Writer, Small Group Leader (SLC), Special Mission Unit, White House Communication Agency, Defense Information Systems Agency, Security Forces Assistance Brigade (SFAB), Joint Communication Unit, Sexual Assault Response Coordinator/Victim Advocate. Critical Development assignments are: **Info Tech Security MGR, Info Tech Supervisor, Info Tech Staff NCO.**

MSG Broadening Assignments are: Senior Instructor, Special Mission Unit, White House Communication Agency, Defense Information Systems Agency, NATO, Senior Career Management NCO, Senior Career Advisor (HRC), Equal Opportunity Advisor. Critical Development assignments are: **Information Technology Chief.**

SGM Broadening Assignments are: HRC Branch SGM, Sergeants Major Academy (SGM-A) Fellowship Program. Critical Development assignments are: **Senior Information Technology Chief.**



MOS 25B

TRAINING

Most qualified looks like:

SSG: Ranger School, Jump Master, Battle Staff NCO Course, Signal Digital Master Gunner, Management Client Course, Joint C4 Planner Course

SFC: Ranger School, Jump Master, Battle Staff NCO Course, Signal Digital Master Gunner, SHARP, Joint C4 Planner Course

MSG: Jump Master, Signal Digital Master Gunner, Company Commander & First Sergeant Pre-Command Course, Joint C4 Planner Course

SGM: Jump Master, Signal Digital Master Gunner, Joint C4 Planner Course

Highly qualified looks like:

SSG: Air Assault, Airborne, Master Fitness Trainer, Instructor Course (CFD-IC)

SFC: Air Assault, Airborne, Master Fitness Trainer, Instructor Course (CFD-IC)

MSG: Air Assault, Airborne, Master Fitness Trainer.

SGM: Air Assault, Airborne

OTHER INDICATORS

Most qualified looks like:

SSG: Audie Murphy/SGT Morales member, NCO of the Year/Quarter, Instructor Badge (Basic/Senior/Master), Recruiter Badge (Silver/Gold), Order of the Mercury

SFC: Audie Murphy/SGT Morales member, NCO of the Year/Quarter, Instructor Badge (Basic/Senior/Master), Recruiter Badge (Silver/Gold), Order of the Mercury

MSG: Audie Murphy/SGT Morales member, NCO of the Year/Quarter, Instructor Badge (Basic/Senior/Master), Recruiter Badge (Silver/Gold), Order of the Mercury

SGM/CSM: Order of Mercury



U.S. ARMY

25H Talent Development Model (Caps at MSG)

Years of Service	2	4	6	8	10	12	14	16	18	20	22	24	26	28	30	
Key Leadership Position <small>MQ rating and highly numerated ranking</small>		Senior System Operator	Section Supervisor			Platoon Sergeant, Detachment Sergeant			First Sergeant			See 25X for SGM/CSM				
Military/Civilian Education	DLC 1	DLC 2	DLC 3				DLC 4			DLC 5			See 25X for SGM/CSM			
Key Development	System Operator	Sr Network Communication SYS Specialist, Sr Cable SYS Installer, Sr Transmissions Sys Operator, Operation NCO	Network Communication SYS Supervisor, Transmissions SYS Plans/Operations NCO			Associate Degree IAT lvl I, IAT lvl II		MLC	Network Communication SYS Manager, Network Communication SYS Planner, Switch System Chief,	Sr Network Communication SYS Manager			See 25X for SGM/CSM			
Broadening Opportunities	White House Communications Agency (WHCA), Security Force Assistance Brigade (SFAB)											See 25X for SGM/CSM				
		Drill SGT, Recruiter, Small Group Leader, Instructor/Writer, Training Developer, NATO Observer/Controller				Inspector General, Equal Opportunity Advisor, Special Missions Unit, Defense Information Systems Agency, Joint Communications Support Element, Joint Communications Unit, Defense Attached				SR Career Management NCO (Proponent), SR Talent Management NCO, Dep CMDT NCO, Branch Chief/1SG NCOA, Chief Training Developer						
Military Training	Ranger, Airborne, Air Assault											See 25X for SGM/CSM				
		Signal Digital Master Gunner, SHARP, Joint C4 Planner Course, Master Resiliency Training Course Battle Staff NCO				Air Load Planner, Master Fitness Trainer				Jumpmaster Course, Master Fitness Trainer Course, Military Equal Opportunity Advisor Course, Management Client Course, Common Faculty Development-Instructor Course, Operational Contract Support Course						
										Mission Command Digital Master Gunner, Capabilities Development Course, Common Faculty Development-Instructor Course, Company Commander/First Sergeant Course, Operational Contract Support Course						



MOS 25H

The Network Communication Systems Specialist supervises, installs, operates and performs limited field level maintenance on commercial and tactical fiber, cabling and wiring, IP based nodal systems, integrated network, line-of-site communications systems and associated equipment. Performs network management functions in support of maintaining, troubleshooting, and reengineering of networks in support of operational requirements.

LEADERSHIP POSITIONS

Most qualified looks like:

- SSG: Section Supervisor for 24 or more months
- SFC: Platoon/Detachment Sergeant for 24 or more months
- MSG: First Sergeant for 24 or more months

Highly qualified looks like:

- SSG: Section Supervisor for 18 to 24 months
- SFC: Platoon/Detachment Sergeant for 18 to 24 months
- MSG: First Sergeant for 18 to 24 months



MOS 25H

PHYSICAL FITNESS

Most qualified looks like:

- SSG: 540 on ACFT
- SFC: 540 on ACFT
- MSG: 540 on ACFT

Highly qualified looks like:

- SSG: 510 on ACFT
- SFC: 510 on ACFT
- MSG: 510 on ACFT

MILITARY/CIVILIAN EDUCATION/CERTIFICATIONS

Most qualified looks like:

- SSG: ALC Distinguished Honor Grad/Honor Grad; 30+ Credit hours; Cisco Certified Entry Networking Technician (CCENT), CompTIA Network+ certification;
- SFC: SLC Distinguished Honor Grad/Honor Grad; Associate Degree; Cisco Certified Entry Networking Technician (CCENT), CompTIA Network+ certification; CompTIA Security+ certification
- MSG: MLC Distinguished Honor Grad/Honor Grad; Bachelor's Degree; Cisco Certified Entry Networking Technician (CCENT), CompTIA Network+ certification; CompTIA Security+ certification

Highly qualified looks like:

- SSG: Commandant List; -30 semester hours of College; Certified Entry Networking Technician (CCENT)
- SFC: Commandant List; 30+ semester hours of College; CompTIA Network+ certification
- MSG: Commandant List; Associate Degree; CompTIA Network+ certification



MOS 25H

ASSIGNMENTS (Broadening and Critical Developmental)
PROPONENT SPECIFIC CHALLENGING/HIGH RISK

SSG Broadening Assignments are: Drill Sergeant, Recruiter, Instructor/Writer, Small Group Leader (ALC), White House Communication Agency, Security Forces Assistance Brigade (SFAB), Joint Communication Unit, Joint Communications Support Element. Critical Development assignments are: Network Communication SYS Supervisor, Transmissions SYS Supervisor, Plans/Operations NCO.

SFC Broadening Assignments are: Inspector General, Equal Opportunity Advisor, Special Missions Unit, Joint Communications Support Element, Joint Communications Unit, Career Management NCO (Proponent), Instructor/Writer, SR Drill Sergeant, Recruiter, Small Group Leader, Observer Controller/Trainer. Critical Development assignments are: Network Communication SYS Manager, Network Communication SYS Planner, Switch System Chief.

MSG Broadening Assignments are: Senior Instructor, Special Mission Unit, White House Communication Agency, Defense Information Systems Agency, NATO, Senior Career Advisor (HRC), Equal Opportunity Advisor. Critical Development assignments are: Sr Network Communication SYS Manager.



MOS 25H

TRAINING

Most qualified looks like:

SSG: Ranger School, Jump Master, Battle Staff NCO Course, Signal Digital Master Gunner, Management Client Course,

SFC: Ranger School, Jump Master, Battle Staff NCO Course, Signal Digital Master Gunner, SHARP, Joint C4 Planner Course

MSG: Jump Master, Signal Digital Master Gunner, Company Commander & First Sergeant Pre-Command Course, Management Client Course, Joint C4 Planner Course

Highly qualified looks like:

SSG: Air Assault, Airborne, Master Fitness Trainer, Management Client Course,

SFC: Air Assault, Airborne, Master Fitness Trainer, Management Client Course, Signal Digital Master Gunner,

MSG: Air Assault, Airborne, Master Fitness Trainer, Management Client Course, Signal Digital Master Gunner

OTHER INDICATORS

Most qualified looks like:

SSG: Audie Murphy/SGT Morales member, NCO of the Year/Quarter, Instructor Badge (Basic/Senior/Master), Recruiter Badge (Silver/Gold), Order of the Mercury

SFC: Audie Murphy/SGT Morales member, NCO of the Year/Quarter, Instructor Badge (Basic/Senior/Master), Recruiter Badge (Silver/Gold), Order of the Mercury

MSG: Audie Murphy/SGT Morales member, NCO of the Year/Quarter, Instructor Badge (Basic/Senior/Master), Recruiter Badge (Silver/Gold), Order of the Mercury



U.S. ARMY

25U Talent Development Model (Caps at MSG)

Years of Service	2	4	6	8	10	12	14	16	18	20	22	24	26	28	30
Key Leadership Position <small>MQ rating and highly numerated ranking</small>		Team Chief		Section Chief, Radio Retrans Supervisor		Section Chief, Platoon Sergeant, Detachment Sergeant/NCO		First Sergeant, Signal Opns Sec Chief							
Military/Civilian Education	DLC 1 Start College IAT LVL I Certs	DLC 2 30+ Credit Hours IAT LVL II / IAM LVL I Certs	DLC 3 Associate Degree IAT LVL II-III / IAM LVL I-II Certs	DLC 4 Bachelor's Degree IAT LVL III / IAM LVL II-III Certs	DLC 5										
Critical Development	Forward Signal Support Spt, Signal Opns Spt Sp, Signal Maint Spt, Radio Retrans Opr, Signal Tac Net Sp	Forward Signal Spt NCO, Signal Advisor, GCC/ASCC Commo NCO, Signal Maint NCO, Signal Opns Spt NCO	Signal Opns NCO, Forward Signal Spt NCO, Signal TAC NET NCO, Signal Advisor, GCC/ASCC Commo NCO, SR Signal Maint NCO			SR Signal Opns NCO, SR GCC/ASCC Commo NCO		Signal Opns Sec Chief							
Broadening Opportunities	Security Forces Assistance Brigade (SFAB)	Drill Sergeant, Recruiter, NCOA Small Group Leader, Instructor/Writer, Defense Information Systems Agency (DISA), White House Communication Agency, Security Forces Assistance Brigade, Joint Communication Unit (JCU), Joint Communications Support Element, Training with Industry	Senior Instructor/Writer, White House Communication Agency, Defense Information Systems Agency, Training with Industry, NATO, Special Mission Unit, Joint Communication Unit (JCU), Joint Communications Support Element (JCSE), Security Force Assistance Brigade (SFAB)					Senior Instructor, Assistant Cmdt NCOA, Sr. Career Management NCO, Senior Talent Management NCO							
Military Training	Air Assault Airborne IAT LVL I Certs	Air Assault, Ranger, Airborne, Jumpster, Marksmanship Master Trainer, Master Resilience Trainer, Signal Digital Master Gunner, Management Client Course, Master Fitness Trainer, SEJPME - I	Air Assault, Ranger, Airborne, Jumpster, Marksmanship Master Trainer, Master Resilience Trainer, Signal Digital Master Gunner, Management Client Course, Master Fitness Trainer, SEJPME - II, Joint C4 Planner Course, Battle Staff NCO					Air Assault, Ranger, Airborne, Jumpster, Master Fitness Trainer, Master Resilience Trainer, Signal Digital Master Gunner, SEJPME - II, Joint C4 Planner Course, Battle Staff NCO							



U.S. ARMY

MOS 25U

The Signal Support Systems Specialist supervises, installs, deploys, maintains, troubleshoots, trains, and assists the General Purpose User with Programs of Record (POR) and Commercial off the Shelf (COTS) communications equipment, as appropriate, within the Tactical Operations Center (TOC), Command Post (CP), and vehicle platforms.

LEADERSHIP POSITIONS

Most qualified looks like:

SSG: Section Chief, Radio Retrans Supervisor for 24 or more months

SFC: Platoon/Detachment Sergeant for 24 or more months

MSG: First Sergeant, Signal Operations Chief for 24 or more months

Highly qualified looks like:

SSG: Section Chief, Radio Retrans Supervisor for 18 to 24 months

SFC: Platoon/Detachment Sergeant for 18 to 24 months

MSG: First Sergeant, Signal Operations Chief for 18 to 24 months



U.S. ARMY

MOS 25U

PHYSICAL FITNESS

Most qualified looks like:

SSG: 540 on ACFT

SFC: 540 on ACFT

MSG: 540 on ACFT

Highly qualified looks like:

SSG: 510 on ACFT

SFC: 510 on ACFT

MSG: 510 on ACFT

MILITARY/CIVILIAN EDUCATION/CERTIFICATIONS

Most qualified looks like:

SSG: ALC Distinguished Honor Grad/Honor Grad; 30+ Credit hours; CompTIA A+ certification

SFC: SLC Distinguished Honor Grad/Honor Grad; Associate Degree; CompTIA Network+ certification

MSG: MLC Distinguished Honor Grad/Honor Grad; Bachelor's Degree; CompTIA Network+ certification; CompTIA Security+ certification

Highly qualified looks like:

SSG: Commandant List; 20+ semester hours of College

SFC: Commandant List; 30+ semester hours of College; CompTIA A+ certification

MSG: Commandant List; Associate Degree; CompTIA Network+ certification



MOS 25U

ASSIGNMENTS (Broadening and Critical Developmental) **PROPONENT SPECIFIC CHALLENGING/HIGH RISK**

SSG Broadening Assignments are: Drill Sergeant, Recruiter, Instructor/Writer, Small Group Leader (ALC), White House Communication Agency, Security Forces Assistance Brigade (SFAB), Joint Communication Unit, Inspector General. Critical Development assignments are: Signal Opns NCO, Forward Signal Spt NCO, Signal TAC NET NCO, Signal Advisor, GCC/ASCC Commo NCO, SR Signal Maint NCO.

SFC Broadening Assignments are: Inspector General, Equal Opportunity Advisor, Special Missions Unit, Joint Communications Support Element, Joint Communications Unit, Career Management NCO (Proponent), Instructor/Writer, SR Drill Sergeant, Recruiter, Small Group Leader, Observer Controller/Trainer. Critical Development assignments are: SR Signal Opns NCO, SR GCC/ASCC Commo NCO.

MSG Broadening Assignments are: Senior Instructor, Special Mission Unit, White House Communication Agency, Defense Information Systems Agency, NATO, Senior Career Advisor (HRC), Equal Opportunity Advisor. Critical Development assignment is: Signal Operations Chief



MOS 25U

TRAINING

Most qualified looks like:

SSG: Ranger School, Jump Master, Battle Staff NCO Course, Signal Digital Master Gunner, Management Client Course.

SFC: Ranger School, Jump Master, Battle Staff NCO Course, Signal Digital Master Gunner, SHARP, Joint C4 Planner Course.

MSG: Jump Master, Signal Digital Master Gunner, Company Commander & First Sergeant Pre-Command Course, Management Client Course, Joint C4 Planner Course.

Highly Qualified looks like:

SSG: Air Assault, Airborne, Master Fitness Trainer.

SFC: Air Assault, Airborne, Master Fitness Trainer, Signal Digital Master Gunner.

MSG: Air Assault, Airborne, Master Fitness Trainer, Signal Digital Master Gunner, Joint C4 Planner Course.

OTHER INDICATORS

Most qualified looks like:

SSG: Audie Murphy/SGT Morales member, NCO of the Year/Quarter, Instructor Badge (Basic/Senior/Master), Recruiter Badge (Silver/Gold), Order of the Mercury.

SFC: Audie Murphy/SGT Morales member, NCO of the Year/Quarter, Instructor Badge (Basic/Senior/Master), Recruiter Badge (Silver/Gold), Order of the Mercury.

MSG: Audie Murphy/SGT Morales member, NCO of the Year/Quarter, Instructor Badge (Basic/Senior/Master), Recruiter Badge (Silver/Gold), Order of the Mercury.

25S Talent Development Model (Caps at MSG)



Years of Service	2	4	6	8	10	12	14	16	18	20	22	24	26	28	30
Key Leadership Position <small>MQ rating and highly numerated ranking</small>	SATCOM Operator	Team Chief	SATCOM Supervisor	SATCOM Supervisor	SATCOM Supervisor	Platoon/ Detachment Sergeant	Platoon/ Detachment Sergeant	Platoon/ Detachment Sergeant	Platoon/ Detachment Sergeant	Platoon/ Detachment Sergeant	Platoon/ Detachment Sergeant	Platoon/ Detachment Sergeant	Platoon/ Detachment Sergeant	Platoon/ Detachment Sergeant	Platoon/ Detachment Sergeant
Military/Civilian Education	DLC 1 WLC	DLC 2 ALC	DLC 3 SLC	DLC 3 SLC	DLC 3 SLC	DLC 4	DLC 4	DLC 4	DLC 4	DLC 4	DLC 5	DLC 5	DLC 5	DLC 5	DLC 5
Critical Development	SATCOM TRG SPC	SR SATCOM Operator SR SATCOM Controller SATCOM OPS SGT SATCOM Training NCO Circuit Control TM Chief	SATCOM System Supervisor Circuit Control Supervisor MILSTAR Team Chief SATCOM Maintenance Supervisor SATCOM Operations NCO	SATCOM System Supervisor Circuit Control Supervisor MILSTAR Team Chief SATCOM Maintenance Supervisor SATCOM Operations NCO	SATCOM System Supervisor Circuit Control Supervisor MILSTAR Team Chief SATCOM Maintenance Supervisor SATCOM Operations NCO	SR SATCOM OPS NCO	SR SATCOM OPS NCO	SR SATCOM OPS NCO	SR SATCOM OPS NCO	SATCOM OPS Chief SATCOM Systems Chief	SATCOM OPS Chief SATCOM Systems Chief	SATCOM OPS Chief SATCOM Systems Chief	SATCOM OPS Chief SATCOM Systems Chief	SATCOM OPS Chief SATCOM Systems Chief	SATCOM OPS Chief SATCOM Systems Chief
Broadening Opportunities	Joint Communication Support Element (JCSE), White House Communications Agency (WHCA), Security Force Assistance Brigade (SFAB)										See 25X for SGM/CSM				
Military Training	Airborne, Air Assault, Ranger, Jump Master, Marksmanship Master Trainer, Master Resilience Trainer, Master Fitness Trainer, SHARP Foundations										See 25X for SGM/CSM				
	Joint C4 Planners Course, Advanced EHF Mission Planners Course, COMSEC Account Manager Course, Battle Staff Course, SE/PME 1/2										See 25X for SGM/CSM				



MOS 25S



The Satellite Communication (SATCOM) Systems Operator-Maintainer supervises, installs, operates and maintains tactical through strategic multichannel satellite communications ground terminals, systems, networks and associated equipment.

LEADERSHIP POSITIONS

Most qualified looks like:

- SSG: SATCOM Supervisor for 24 or more months
- SFC: Platoon/Detachment Sergeant, Section Chief for 24 or more months
- MSG: First Sergeant for 24 or more months

Highly qualified looks like:

- SSG: SATCOM Supervisor for 18 to 24 months
- SFC: Platoon/Detachment Sergeant, Section Chief for 18 to 24 months
- MSG: First Sergeant for 18 to 24 months



MOS 25S

PHYSICAL FITNESS

Most qualified looks like:

SSG: 540 on ACFT

SFC: 540 on ACFT

MSG: 540 on ACFT

Highly qualified looks like:

SSG: 510 on ACFT

SFC: 510 on ACFT

MSG: 510 on ACFT

MILITARY/CIVILIAN EDUCATION/CERTIFICATIONS

Most qualified looks like:

SSG: ALC Distinguished Honor Grad/Honor Grad; 30+ Credit hours; CompTIA A+ Certification, Certified Satellite Installer (CSI), Electronics Associate AC (EM2),

SFC: SLC Distinguished Honor Grad/Honor Grad; Associate Degree; CompTIA Network+ Certification, Certified Satellite Installer (CSI), Electronics Associate AC (EM2), Electronics Associate Analog (EM3)

MSG: MLC Distinguished Honor Grad/Honor Grad; Bachelor's Degree; Cisco Certified Entry Networking Technician (CCENT)

Highly qualified looks like:

SSG: Commandant List; 20+ semester hours of College; Certified Satellite Installer (CSI)

SFC: Commandant List; 30+ semester hours of College; CompTIA Network+ certification

MSG: Commandant List; Associate Degree; CompTIA Network+ certification, Electronics Associate AC (EM2)



MOS 25S

ASSIGNMENTS (Broadening and Critical Developmental)
PROPONENT SPECIFIC CHALLENGING/HIGH RISK

SSG Broadening Assignments are: Drill Sergeant, Recruiter, Instructor/Writer, Small Group Leader (ALC), White House Communication Agency, Security Forces Assistance Brigade (SFAB), Joint Communications Support Element. Critical Development assignments are: SATCOM System Supervisor, Circuit Control Supervisor, MILSTAR Team Chief, SATCOM Maintenance Supervisor.

SFC Broadening Assignments are: Drill Sergeant, Recruiter, Instructor/Writer, Small Group Leader (SLC), White House Communication Agency, Security Forces Assistance Brigade (SFAB), Joint Communications Support Element. Critical Development assignments is: SR SATCOM OPS NCO.

MSG Broadening Assignments are: Special Mission Unit, White House Communication Agency, NATO, Senior Career Advisor (HRC), Equal Opportunity Advisor. Critical Development assignments are: SATCOM Ops Chief, SATCOM Syst Chief.



MOS 25S

TRAINING

Most qualified looks like:

SSG: Jump Master, Signal Digital Master Gunner, Management Client Course

SFC: Jump Master, Battle Staff NCO Course, Signal Digital Master Gunner, SHARP, Joint C4 Planner Course

MSG: Jump Master, Signal Digital Master Gunner, Company Commander & First Sergeant Pre-Command Course, Management Client Course, Joint C4 Planner Course

Highly qualified looks like:

SSG: Air Assault, Airborne, Management Client Course,

SFC: Air Assault, Airborne, Trainer, Management Client Course, Signal Digital Master Gunner,

MSG: Air Assault, Airborne, Management Client Course, Signal Digital Master Gunner

OTHER INDICATORS

Most qualified looks like:

SSG: Audie Murphy/SGT Morales member, NCO of the Year/Quarter, Instructor Badge (Basic/Senior/Master), Recruiter Badge (Silver/Gold), Order of the Mercury

SFC: Audie Murphy/SGT Morales member, NCO of the Year/Quarter, Instructor Badge (Basic/Senior/Master), Recruiter Badge (Silver/Gold), Order of the Mercury

MSG: Audie Murphy/SGT Morales member, NCO of the Year/Quarter, Instructor Badge (Basic/Senior/Master), Recruiter Badge (Silver/Gold), Order of the Mercury



U.S. ARMY

MOS 25D (accesses at SSG)

Years of Service	2	4	6	8	10	12	14	16	18	20	22	24	26	28	30
Key Leadership Position <small>MQ rating and highly numerated ranking</small>	<p>MOS 25D has no authorizations for Team Chief, Platoon Sergeant, or First Sergeant or Command Sergeant Major.</p> <p>MOS 25D Soldiers are not authorized for assignment as Recruiters, Drill Sergeant, Platoon Sergeants, First Sergeants, Command Sergeants Major, Inspector General (IG), or Equal Opportunity Advisors (EOA).</p>														
Military/Civilian Education				DLC 3			DLC 4			DLC 5			DLC 6		
				30+Credit Hours IAT LVL II / IAM LVL I Certs CSSP Analyst	SLC		Associate Degree IAT LVL II-III / IAM LVL I-II Certs CSSP Auditor/	MLC		Bachelor's Degree IAT LVL III / IAM LVL II-III Certs CSSP Auditor/	SGM-A		Master's Degree IAM LVL III Certs CSSP Auditor/ Incident Responder		
Critical Development				Infrastructure Supporter, CND Analyst, Cyber Mission Units			Infrastructure Supporter, Senior Analyst, Auditor, Joint/DOD, Cyber Mission Units			Senior Incident Responder, Senior Auditor, CND Manager, Regional Cyber Center or ASCC			Senior CND Manager, Regional Cyber Center		
Broadening Opportunities				Cyber Protection Teams, White House Communication Agency (WHCA), Defense Information Systems Agency (DISA), ARCYBER, Security Force Assistance Brigade (SFAB), Cyber Warfare Support Battalion (CWSB)			Cyber Protection Teams, White House Communication Agency (WHCA), Defense Information Systems Agency (DISA), ARCYBER, U.S. Special Operations Command (USSOCOM), Instructor/Writer			Army Cyber Command, USSOCOM, Cyber Protection Brigade,					
Military Training				Airborne, Air Assault, Jumpmaster, Basic Computer Network Operations Course (BCNOPC), Security Force Assistance Brigade (SFAB), Master Fitness Trainer, Master Resilience Trainer, Joint C4 Planner, SEJPME – II			Airborne, Air Assault, Jumpmaster, Basic Computer Network Operations Course (BCNOPC), Incident Handler, Forensic Analyst/Systems and Network Auditor, Master Fitness Trainer, Master Resilience Trainer, Joint C4 Planner, SEJPME – II						Air Assault, Master Fitness Trainer, Executive Cyberspace Operations Planners Seminar (ECOPS), Joint C4 Planner, SEJPME – II		



U.S. ARMY

MOS 25D

The Cyber Network Defender performs the duties associated with the five Computer Network Defense (CND) specialties (Infrastructure Support, Analyst, Incident Responder, Auditor and Manager), Information Assurance Technical (IAT) Levels I-III functions, Information Assurance Management (IAM) Levels I-III functions, as required by skill level IAW AR 25-2 and DoD 8140.03-M.

LEADERSHIP POSITIONS

SSG: Infrastructure Support 12 months, CND Analyst 12 months

SFC: Infrastructure Support 12 months, Senior CND Analyst 12 months

MSG: Senior Incident Responder 12 months, Senior Auditor 12 months, CND Manager 12 months

SGM: Senior CND Manager 24 months, Regional Cyber Center 24 months



MOS 25D

PHYSICAL FITNESS

Most qualified looks like:

- SSG: 540 on ACFT
- SFC: 540 on ACFT
- MSG: 540 on ACFT
- SGM: 540 on ACFT

Highly qualified looks like:

- SSG: 510 on ACFT
- SFC: 510 on ACFT
- MSG: 510 on ACFT
- SGM: 510 on ACFT

MILITARY/CIVILIAN EDUCATION

Most qualified looks like:

- SSG: Distinguished Honor Grad/Honor Grad; 30+ college credits; Information Assurance Technician Level II / Information Assurance Management Level I cert, CompTIA Cybersecurity Analyst, EC-Council Certified Network Defender, Certified Ethical Hacker, Microsoft Certified Solutions Expert
- SFC: Distinguished Honor Grad/Honor Grad; Associate Degree; Information Assurance Technician Level III / Information Assurance Management Level II cert, Certified Ethical Hacker, Cisco Certified Network Professional, GIAC Certified Forensics Analyst, Microsoft Certified Solutions Expert
- MSG: Distinguished Honor Grad/Honor Grad; Bachelor's Degree; Information Assurance Technician Level III / Information Assurance Management Level III cert, Certified Ethical Hacker, Certified Information Systems Auditor, GIAC Systems and Network Auditor, Microsoft Certified Solutions Expert
- SGM: Master's Degree; Information Assurance Management Level III, Certified Information Systems Security Professional, Certified Information Security Manager, Certified Chief Information Security Officer, Microsoft Certified Solutions Expert

Highly qualified looks like:

- SSG: Commandant List; 20+ semester hours of College; Information Assurance Technician Level II
- SFC: Commandant List; 30+ college credits; Information Assurance Technician Level II / Information Assurance Management Level I cert
- MSG: Commandant List; Associate College; Information Assurance Technician Level II / Information Assurance Management Level I-II
- SGM: Bachelor's Degree; Information Assurance Technician Level II-III / Information Assurance Management Level II



MOS 25D

ASSIGNMENTS (Broadening and Critical Developmental) PROPONENT SPECIFIC CHALLENGING/HIGH RISK

SSG Broadening assignments are: Special Mission Unit, White House Communication Agency, Defense Information Systems Agency, SFAB, ARCYBER. **Critical Development assignments are:** Infrastructure Support, Analyst

SFC Broadening assignments are: Instructor/Writer, Special Mission Unit, White House Communication Agency, Defense Information Systems Agency, ARCYBER. **Critical Development assignments are:** Senior Analyst, Incident Responder, Auditor.

MSG Broadening assignments are: Special Mission Unit, ARCYBER. **Critical Development assignments are:** Senior Incident Responder, Senior Auditor, CND Manager

SGM Broadening assignments are: ARCYBER. **Critical Development assignments are:** Senior CND Manager



MOS 25D

TRAINING

Most qualified looks like:

SSG: Ranger School, Jump Master, Battle Staff NCO Course, Joint C4 Planner Course

SFC: Ranger School, Jump Master, Battle Staff NCO Course, Instructor Course (CFD-IC), Joint C4 Planner Course

MSG: Ranger School, Jump Master, Battle Staff NCO Course, Joint C4 Planner Course

SGM: Ranger School, Jump Master, Joint C4 Planner Course

Highly qualified looks like:

SSG: Air Assault, Airborne, Master Fitness Trainer, Management Client Course, Master Resilience Trainer

SFC: Air Assault, Airborne, Master Resilience Trainer, Master Fitness Trainer

MSG: Air Assault, Airborne,

SGM: Air Assault, Airborne

OTHER INDICATORS

Most qualified looks like:

SSG: NCO of the Quarter/Year, Sergeant Audie Murphy Club, Sergeant Morales Club, Distinguished Leader Award, Expert Soldier Badge, Best Warrior Competition

SFC: Instructor of the Quarter/Year, NCO of the Quarter/Year, Sergeant Audie Murphy Club, Sergeant Morales Club, Distinguished Leader Award, Expert Soldier Badge, Best Warrior Competition

MSG: Distinguished Leader Award, Expert Soldier Badge





SGM: Order of Mercury



U.S. ARMY

MOS 25E (accesses at SSG)

Years of Service 2 4 6 8 10 12 14 16 18 20 22 24 26 28 30

																				
Key Leadership Position MQ rating and highly numerated ranking	<p>MOS 25E has no authorizations for Team Chief, Platoon Sergeant, First Sergeant, or Command Sergeant Major.</p> <p>MOS 25E Soldiers are not authorized for assignment as Recruiters, Drill Sergeant, Inspector General (IG), or Equal Opportunity Advisors (EOA).</p>																			
Military/Civilian Education																				
Key Development																				
Broadening Opportunities																				
Military Training																				

MOS 25E has no authorizations for Team Chief, Platoon Sergeant, First Sergeant, or Command Sergeant Major.

MOS 25E Soldiers are not authorized for assignment as Recruiters, Drill Sergeant, Inspector General (IG), or Equal Opportunity Advisors (EOA).

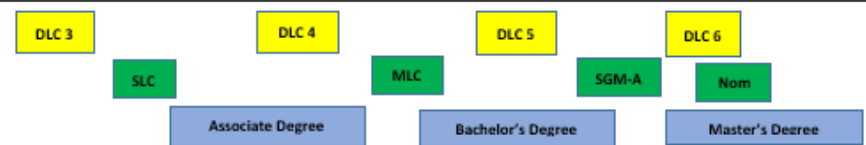

Electromagnetic Spectrum Mgr, Electro Spec NCO, Corps Spec Manager, Theater Spec Mgmt NCO

Spectrum Mgmt Chief, Corps Spec Mgmt Chief, Theater Spec Mgmt Chief, Joint Electronic Spec Mgr, CCMD J-6 JFMO NCOIC

Joint Spectrum Manager, Senior Spec Mgr, Army Spectrum Mgmt Chief, CCMD J-6 JFMO NCOIC

Senior Army Spectrum Management Chief, Senior Spec Mgr

Defense Information Systems Agency (DISA), White House Communications Agency (WHCA), Joint Spectrum Center (JSC), Security Forces Assistance Brigade (SFAB)

Instructor/Writer, Training Developer, Capability Developer NCO

DISA, USASMA/OCLL Fellowships, Joint and Combined Warfighting School (JCWS)

Ranger, Airborne, Air Assault, Master Fitness, Master Resilience

ASI S9 – Joint Spectrum Manager



MOS 25E

The Electromagnetic Spectrum Manager develops, produces, and distributes the Signal Operating Instructions (SOI) using computer software programs; maintains a database of frequency requests and assignments and performs periodic reviews and updates; takes steps to resolve frequency interference reports and maintains a database of interference incidents; and performs unlimited frequency planning, selection, and de-confliction using automated tools.

LEADERSHIP POSITIONS

Most qualified looks like:

SSG: Electromagnetic Spectrum Manager 12 months, Corps Spectrum Manager 12 months, Theater Spectrum Manager 12 months

SFC: Spectrum Management Chief 12 months, Corps Spectrum Management Chief 12 months, Theater Spectrum Management Chief 12 months, Army Spectrum Management Chief 12 months

MSG: Joint Electronic Spectrum Manager 12 months, Senior Spectrum Manager 12 months

SGM: Senior Army Spectrum Manager 24 months



U.S. ARMY

MOS 25E

PHYSICAL FITNESS

Most qualified looks like:

SSG: 540 on ACFT

SFC: 540 on ACFT

MSG: 540 on ACFT

SGM: 540 on ACFT

Highly qualified looks like:

SSG: 510 on ACFT

SFC: 510 on ACFT

MSG: 510 on ACFT

SGM: 510 on ACFT

MILITARY/CIVILIAN EDUCATION

Most qualified looks like:

SSG: Distinguished Honor Grad/Honor Grad; 30+ college credits

SFC: Distinguished Honor Grad/Honor Grad; Associate Degree

MSG: Distinguished Honor Grad/Honor Grad; Bachelor's Degree

SGM: Distinguished Honor Grad/Honor Grad; Master's Degree

Highly qualified looks like:

SSG: Commandant List; 20+ college credits

SFC: Commandant List; 30+ college credits

MSG: Commandant List; Associate College

SGM: Commandant List; Bachelor's Degree



MOS 25E

ASSIGNMENTS (Broadening and Critical Developmental) PROPONENT SPECIFIC CHALLENGING/HIGH RISK

SSG Broadening assignments are: Instructor/Writer, Asymmetric Warfare Group, NATO, Defense Information Systems Agency, Cyber Protection Brigade, ARCYBER, White House Communication Agency. **Critical Development assignments are:** Electromagnetic Spectrum Mgr, Electro Spec NCO, Corps Spec Manager, Theater Spec Mgmt NCO.

SFC Broadening assignments are: Small Group Leader, Instructor/Writer, Asymmetric Warfare Group, NATO, Defense Information Systems Agency, Cyber Protection Brigade, ARCYBER, White House Communication Agency, Security Forces Assistance Brigade (SFAB). **Critical Development assignments are:** Spectrum Mgmt Chief, Corps Spec Mgmt Chief, Theater Spec Mgmt Chief, Joint Electronic Spec Mgr, CCMD J-6 JFMO NCOIC.

MSG Broadening assignments are: Instructor/Writer, Asymmetric Warfare Group, NATO, Defense Information Systems Agency, Cyber Protection Brigade, ARCYBER, White House Communication Agency, Small Group Leader. **Critical Development assignments are:** Joint Spectrum Manager, Senior Spec Mgr, Army Spectrum Mgmt Chief, CCMD J-6 JFMO NCOIC.

SGM Broadening assignments are: White House Communication Agency, Defense Information Systems Agency, USASMA Fellowship. **Critical Development assignments are:** Senior Army Spectrum Management Chief, Senior Spec Mgr.



MOS 25E

TRAINING

Most qualified looks like:

SSG: Ranger, Jump Master, Battle Staff, Signal Digital Master Gunner (S-DMG)

SFC: Ranger, Jump Master, Battle Staff, Signal Digital Master Gunner (S-DMG)

MSG: Ranger, Jump Master, Battle Staff, Signal Digital Master Gunner (S-DMG)

SGM: Ranger, Jump Master

Highly qualified looks like:

SSG: Air Assault, Airborne, Instructor, Pathfinder, Master Resiliency Trainer

SFC: Air Assault, Airborne, Instructor, Pathfinder, Master Resiliency Trainer

MSG: Air Assault, Airborne, Pathfinder, Master Resiliency Trainer

SGM: Air Assault, Airborne, Pathfinder

OTHER INDICATORS

Most qualified looks like:

SSG: NCO of the Quarter/Year, Sergeant Audie Murphy Club, Sergeant Morales Club, Distinguished Leader Award, Expert Soldier Badge, Best Warrior Competition

SFC: Instructor of the Quarter/Year, NCO of the Quarter/Year, Sergeant Audie Murphy Club, Sergeant Morales Club, Distinguished Leader Award, Expert Soldier Badge, Best Warrior Competition

MSG: Distinguished Leader Award

SGM: Order of Mercury









U.S. ARMY

MOS 25X

Years of Service

2 4 6 8 10 12 14 16 18 20 22 24 26 28 30

	      
Key Leadership Position <small>MQ rating and highly numerated ranking</small>	<p>See 25H, 25S and 25U for SPC-MSG</p> <p>Chief Signal NCO, Senior Enlisted Leader/Advisor</p> <p>BN/BDE CSM Garrison CSM</p>
Military/Civilian Education	<p>See 25H, 25S and 25U for SPC-MSG</p> <p>SGM-A</p> <p>DLC 6</p> <p>Nom</p> <p>Master's Degree IAM Lvl II-III, CAPM, PMP, Certified Lean Sigma Six</p>
Key Development	<p>See 25H, 25S and 25U for SPC-MSG</p> <p>Chief Signal NCO (S3 BN/BDE) Chief Signal NCO (G3) Chief Signal NCO (G6 Division/Corps)</p>
Broadening Opportunities	<p>See 25H, 25S and 25U for SPC-MSG</p> <p>NATO SR Enlisted Leader, SGM-A Fellowship Program, Congressional Fellowship Program, Equal Opportunity Advisor, IG NCO</p> <p>IG NCO, EOA, SMU, WHCA, DISA, JCSE, Ranger</p> <p>Chief Career Management NCO (Proponent), Chief Professional Development NCO/Branch SGM (HRC)</p> <p>Commandant NCOA, Chief Instructor/Writer (SGM-A), Chief Capabilities Development NCO</p>
Military Training	<p>See 25H, 25S and 25U for SPC-MSG</p> <p>Joint C4 Planners Course, Keystone Course, CSM Legal Orientation Course, General Officer Senior Commander's Course, Nominative Leader Course, Pre-Command Course, Battle Staff NCO Course, Mission Command Digital Master Gunner (MC-DMG)</p>



MOS 25X

The Chief Signal NCO, plans, develops, coordinates, directs, and supervises the installation, operation and management of integrated C2 telecommunications and information management networks; writes Command and Control Communications policy; provides technical advice and assistance to commanders, staff, and subordinate units; and coordinates Signal activities with higher, lower and adjacent headquarters.

LEADERSHIP POSITIONS

Most qualified looks like:

- SGM: G6 SGM NCO 24 months
- CSM: CSM for 24 to 30 month period

Highly qualified looks like:

- SGM: G6 SGM NCO 18 months
- SGM/CSM: CSM for 18 to 24 months



U.S. ARMY

MOS 25X

PHYSICAL FITNESS

Most qualified looks like:

SGM/CSM: 540 on ACFT

Highly qualified looks like:

SGM/CSM: 510 on ACFT

MILITARY/CIVILIAN EDUCATION

Most qualified looks like:

SGM/CSM: Master Degree

Highly qualified looks like:

SGM/CSM: Bachelors Degree



U.S. ARMY

MOS 25X

ASSIGNMENTS (Broadening and Critical Developmental) PROONENT SPECIFIC CHALLENGING/HIGH RISK

SGM/CSM: Broadening assignments for SGM/CSM are NCOA Assistant Commandant (MSCOE), USASMA Small Group Leader, and USASMA Fellowship, Signal Proponent SGM. Critical Development Assignment is Battalion/Brigade S3 SGM, G3 SGM, Senior Enlisted Advisor.