

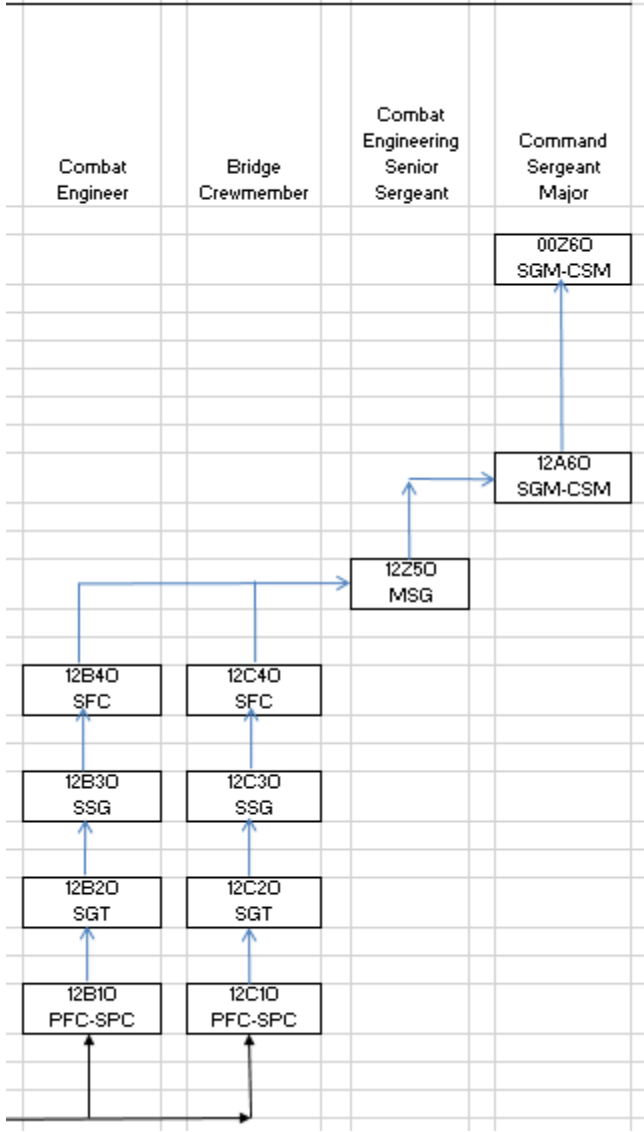

CMF 12 Combat Engineering Progression Chart





CMF 12 General Engineering Progression Chart

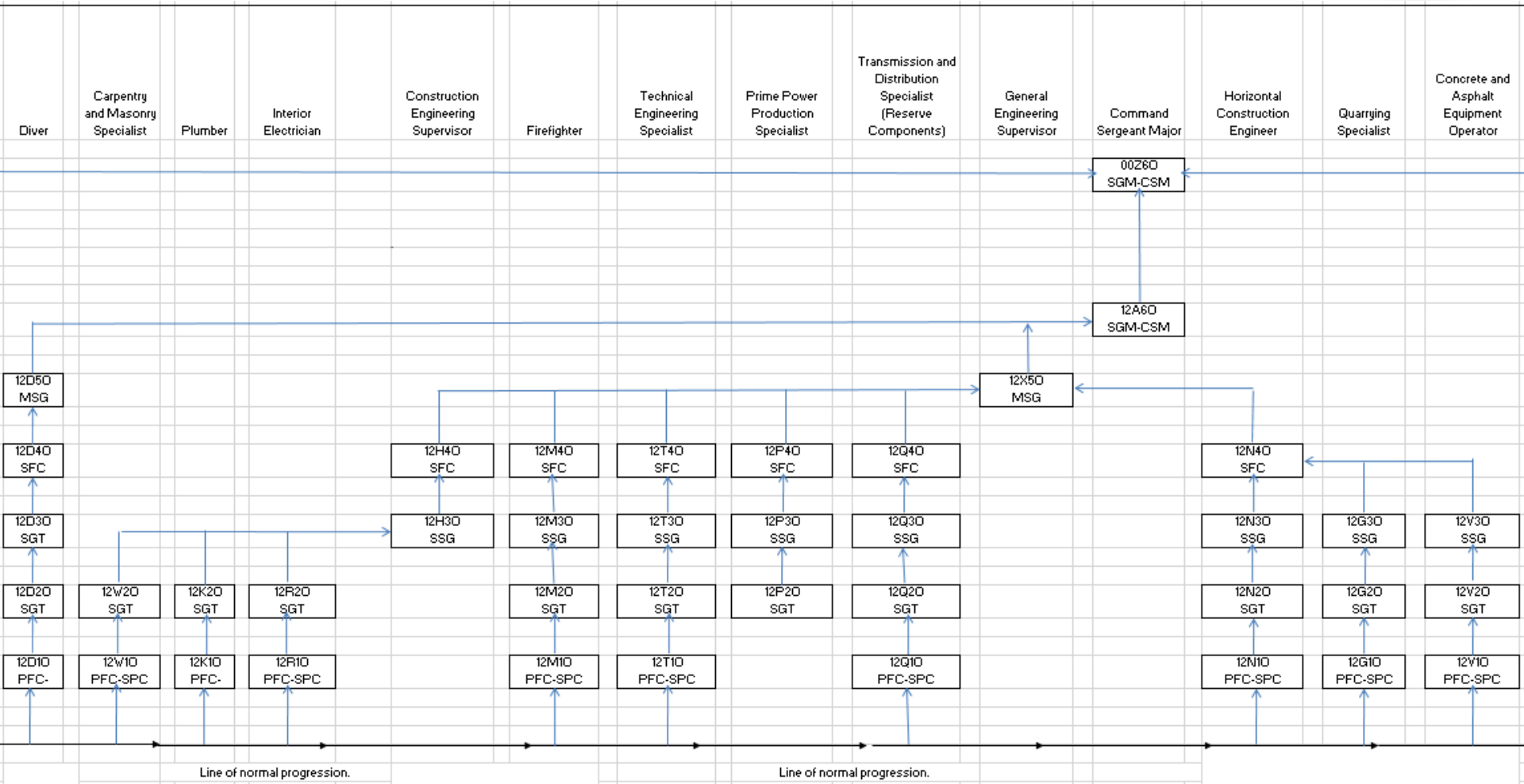



CMF 12 Geospatial Engineering Progression Chart

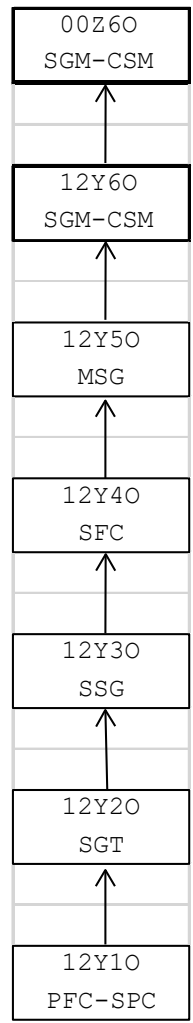



MOS 12A



Engineers Sergeant Major (PDPC 7S) or Command Sergeant Major (PDPC 7C) seeking eligibility at the Senior Enlisted Nominative Level (00Z).

LEADERSHIP POSITIONS

Most Qualified looks like:

SSG: N/A

SFC: N/A

MSG: N/A

CSM/SGM: Successfully served as CSM at 7C level for 24 months or SGM at 7S level for 36 months (nominative eligible)

Highly Qualified looks like:

SSG: N/A

SFC: N/A

MSG: N/A

CSM/SGM: Successfully served as CSM at 7C level for 18 months or SGM at 7S level for 18 months (nominative eligible)



U.S. ARMY

MOS 12A



Combat Engineers Sergeant Major (PDPC 6S or 7S) or Command Sergeant Major (PDPC 6C or 7C) competing for BN or BDE CSL appointment.

LEADERSHIP POSITIONS

Most Qualified looks like:

SSG: N/A

SFC: N/A

MSG: N/A

CSM/SGM: BN CSL: 18 months at brigade or higher staff (6S/7S) or 18 months as a current BN CSM

BDE CSL: 36 months as a BN CSM (6C)

Highly Qualified looks like:

SSG: N/A

SFC: N/A

MSG: N/A

CSM/SGM: BN CSL: 12 months at brigade staff (6S)

BDE CSL: 24 months as a BN CSM (6C)



U.S. ARMY

MOS 12A



PHYSICAL FITNESS

Most Qualified looks like:

SSG: N/A

SFC: N/A

MSG: N/A

CSM/SGM: 270 or above or received the Army Physical Fitness Badge

Highly Qualified looks like:

SSG: N/A

SFC: N/A

MSG: N/A

CSM/SGM: 250 – 269 on APFT

MILITARY, CIVILIAN EDUCATION

Most Qualified looks like:

SSG: N/A

SFC: N/A

MSG: N/A

CSM/SGM: USASMA Distinguished Honor Graduate or Honor Graduate, Masters Degree

Highly Qualified looks like:

SSG: N/A

SFC: N/A

MSG: N/A

CSM/SGM: USASMA Commandants List



MOS 12A



ASSIGNMENTS (Broadening and Key Developmental)
PROPONENT SPECIFIC CHALLENGING / HIGH RISK

SSG: N/A

SFC: N/A

MSG: N/A

CSM/SGM: NCOA Commandant, CSM Observer-Coach Trainer (OC/T), BEB OC/T, BDE CSM OC/T, BEB CSM in SFAB, Chief Career Management NCO (Proponent-USAES), Army Congressional Fellowship, CSA Strategic Studies Group

Army wide Special Duty Assignments are specific, defined and provided in
the Annex to the Board MOI



U.S. ARMY

MOS 12A



TRAINING

Most Qualified looks like:

SSG: N/A

SFC: N/A

MSG: N/A

CSM/SGM: Air Assault, Airborne, Rappel Master, Master Fitness Trainer, Joint Engineer Operations Course (JEOC), MRT, SHARP, EOL

Highly Qualified looks like:

SSG: N/A

SFC: N/A

MSG: N/A

CSM/SGM: SHARP, MRT, EOL

OTHER INDICATORS

Most Qualified looks like:

SSG: N/A

SFC: N/A

MSG: N/A

CSM/SGM: Audie Murphy-SGT Morales (Active Member), Project Management (ASI-P6), Lean Six Sigma Black Belt (ASI-1Y)



MOS 12B



Combat engineers conduct mobility, counter-mobility, and survivability actions in support of combat forces and works as a member of a team, squad, or platoon performing basic combat construction and reconnaissance missions.

LEADERSHIP POSITIONS

Most Qualified looks like:

SSG: 18 months Squad Leader, Sapper Instructor, Section Sergeant (K9) coupled with broadening assignment

SFC: 18 months Platoon Sergeant, Sapper Instructor, Detachment Sergeant (K9) coupled with broadening assignment

MSG: N/A

CSM/SGM: N/A

Highly Qualified looks like:

SSG: 18 months Squad Leader or Section Sergeant

SFC: 18 months Platoon Sergeant or Detachment Sergeant (K9)

MSG: N/A

CSM/SGM: N/A



U.S. ARMY

MOS 12B



PHYSICAL FITNESS

Most Qualified looks like:

SSG: 270 or above or received the Army Physical Fitness Badge; placed 5th or higher at Best Sapper

SFC: 270 or above or received the Army Physical Fitness Badge; placed 5th or higher at Best Sapper

MSG: N/A

CSM/SGM: N/A

Highly Qualified looks like:

SSG: 250 – 269 on APFT

SFC: 250 – 269 on APFT

MSG: N/A

CSM/SGM: N/A

MILITARY/CIVILIAN EDUCATION

Most Qualified looks like:

SSG: ALC Distinguished Honor Graduate or Honor Graduate, AA Degree

SFC: SLC Distinguished Honor Graduate or Honor Graduate, Bachelors Degree

MSG: N/A

CSM/SGM: N/A

Highly Qualified looks like:

SSG: ALC Commandants List, Some College

SFC: SLC Commandants List, AA Degree

MSG: N/A

CSM/SGM: N/A



MOS 12B



ASSIGNMENTS (Broadening and Key Developmental)
PROPONENT SPECIFIC CHALLENGING / HIGH RISK

SSG: Sapper Instructor, Asymmetric Warfare Operational Support, Defense Attaché System, SFAB, training with Industry Program, White House fellowship Program, Observer-Coach Trainer (OC/T), Small Group Leader, Instructor Writer.

SFC: Career Management NCO (Proponent-USAES), Sapper Instructor, Observer-Coach Trainer (OC/T), Asymmetric Warfare Operational Support, AWG Operational Specialist, SFAB, Small Group Leader, Instructor /Writer. EOA, SARC, Military Science Instructor, and Training Developer NCO.

MSG: N/A

CSM/SGM: N/A

Army wide Special Duty Assignments are specific, defined and provided in
the Annex to the Board MOI



U.S. ARMY

MOS 12B



TRAINING

Most Qualified looks like:

SSG: Air Assault, Airborne, Sapper, Ranger, Explosive Ordnance Clearance Agent, MRT, SHARP, EOL

SFC: Air Assault, Airborne, Rappel Master, JEOC, Master Fitness Trainer, EOCA, MRT, SHARP, EOL

MSG: N/A

CSM/SGM: N/A

Highly Qualified looks like:

SSG: SHARP, MRT, EOL

SFC: SHARP, MRT, EOL

MSG: N/A

CSM/SGM: N/A

OTHER INDICATORS

Most Qualified looks like:

SSG: Audie Murphy-SGT Morales (Active Member), Steel de Fleury, Sturgis Award, Army Combat Engineer Sergeants Award, NCO of the Quarter/Year, Six Sigma Green Belt, Senior Instructor Badge

SFC: Audie Murphy-SGT Morales (Active Member), NCO of the Quarter/Year, Bronze de Fleury, Project Management (ASI-P6), Lean Six Sigma Green Belt (ASI-1X), Master Instructor Badge

MSG: N/A

CSM/SGM: N/A



MOS 12C



A Bridge Crewmember commands, serves, and assists as a member of a squad, section, or platoon. A bridge crewmember directs the loading, off-loading, assembly, and disassembly of float and fixed bridges for wet and dry gap crossing operations. Operates and supervises the use of Bridge Erection Boats (BEB) and rafting operations. Installs and supervises the placement of kedge and overhead anchorage systems. The bridge crewmember accomplishes these tasks while staying current in basic Soldiering skills, which is necessary for today's battlefield.

LEADERSHIP POSITIONS

Most Qualified looks like:

- SSG: 18 months Squad Leader coupled with broadening assignment
- SFC: 18 months Platoon Sergeant coupled with broadening assignment
- MSG: N/A
- CSM/SGM: N/A

Highly Qualified looks like:

- SSG: 18 months Squad Leader or Section Sergeant
- SFC: 18 months Platoon Sergeant in operating force
- MSG: N/A
- CSM/SGM: N/A



U.S. ARMY

MOS 12C



PHYSICAL FITNESS

Most Qualified looks like:

SSG: 270 or above or received the Army Physical Fitness Badge; placed 5th or higher at Best Sapper

SFC: 270 or above or received the Army Physical Fitness Badge; placed 5th or higher at Best Sapper

MSG: N/A

CSM/SGM: N/A

Highly Qualified looks like:

SSG: 250 – 269 on APFT

SFC: 250 – 269 on APFT

MSG: N/A

CSM/SGM: N/A

MILITARY/CIVILIAN EDUCATION

Most Qualified looks like:

SSG: ALC Distinguished Honor Graduate or Honor Graduate, AA Degree

SFC: SLC Distinguished Honor Graduate or Honor Graduate, Bachelors Degree

MSG: N/A

CSM/SGM: N/A

Highly Qualified looks like:

SSG: ALC Commandants List, Some College

SFC: SLC Commandants List, AA Degree

MSG: N/A

CSM/SGM: N/A



MOS 12C



ASSIGNMENTS (Broadening and Key Developmental)
PROPONENT SPECIFIC CHALLENGING / HIGH RISK

SSG: Sapper Instructor, Asymmetric Warfare Operational Support, Defense Attaché System, SFAB, White House fellowship Program, Observer-Coach Trainer (OC/T), Small Group Leader, Instructor Writer.

SFC: Sapper Instructor, Asymmetric Warfare Operational Support, AWG Operational Specialist, Defense Attaché System, SFAB, White House Fellowship Program, Observer-Coach Trainer (OC/T), Small Group Leader, Instructor/Writer. EOA, SARC, Career Management NCO, Military Science Instructor, and Training Developer NCO.

MSG: N/A

CSM/SGM: N/A

Army wide Special Duty Assignments are specific, defined and provided in
the Annex to the Board MOI



U.S. ARMY

MOS 12C



TRAINING

Most Qualified looks like:

SSG: Air Assault, Airborne, Sapper, Ranger, Explosive Ordnance Clearance Agent, MRT, SHARP, EOL

SFC: Air Assault, Airborne, Rappel Master, JEOC, Master Fitness Trainer, EOCA, MRT, SHARP, EOL

MSG: N/A

CSM/SGM: N/A

Highly Qualified looks like:

SSG: SHARP, MRT, EOL

SFC: SHARP, MRT, EOL

MSG:

CSM/SGM:

OTHER INDICATORS

Most Qualified looks like:

SSG: Audie Murphy-SGT Morales (Active Member), Steel de Fleury, Sturgis Award, Army Combat Engineer Sergeants Award, NCO of the Quarter/Year, Six Sigma Green Belt, Senior Instructor Badge

SFC: Audie Murphy-SGT Morales (Active Member), NCO of the Quarter/Year, Bronze de Fleury, Project Management (ASI-P6), Lean Six Sigma Green Belt (ASI-1X), Master Instructor Badge

MSG: N/A

CSM/SGM: N/A



MOS 12D



The Engineer Divers perform or supervise SCUBA and Surface-Supplied diving operations to a depth of 190FSW in support of General Engineering, Geospatial Survey, and Defense Support of Civil Authorities (DSCA). The Engineer Diver works as a member of a diving section, team, or detachment performing a multitude of underwater engineering tasks.

LEADERSHIP POSITIONS

Most Qualified looks like:

- SSG: 18 months Diving Supervisor or Recovery Supervisor coupled with TDA assignment
- SFC: 18 months Senior Diving Supervisor or Reconnaissance Team NCOIC coupled with TDA assignment
- MSG: 18 months First Sergeant, Master Diving Supervisor, Chief Diving Supervisor
- CSM/SGM: N/A

Highly Qualified looks like:

- SSG: 18 months Diving Supervisor or Recovery Supervisor
- SFC: 18 months Senior Diving Supervisor or Reconnaissance Team NCOIC
- MSG: 18 months First Sergeant or Master Diving Supervisor
- CSM/SGM: N/A



U.S. ARMY

MOS 12D



PHYSICAL FITNESS

Most Qualified looks like:

SSG: 270 or above or received Army Physical Fitness Badge

SFC: Physical Fitness Badge

MSG: Physical Fitness Badge

CSM/SGM: N/A

Highly Qualified looks like:

SSG: 250 – 289 on APFT

SFC: 250 – 289 on APFT

MSG: 250 – 289 on APFT

CSM/SGM: N/A

MILITARY/CIVILIAN EDUCATION

Most Qualified looks like:

SSG: ALC Distinguished Honor Graduate or Honor Graduate, AA Degree

SFC: SLC Distinguished Honor Graduate or Honor Graduate, Bachelors Degree

MSG: MLC Distinguished Honor Graduate or Honor Graduate, Bachelors Degree

CSM/SGM: N/A

Highly Qualified looks like:

SSG: ALC Commandants List, Some College

SFC: SLC Commandants List, AA Degree

MSG: MLC Commandants List, Three years College

CSM/SGM: N/A



MOS 12D



ASSIGNMENTS (Broadening and Key Developmental)
PROPONENT SPECIFIC CHALLENGING / HIGH RISK

SSG: Drill Sergeant, AIT Platoon Sergeant, Asymmetric Warfare Operational Support, Defense Attaché System (DAS), Training With Industry (TWI) Program, White House Fellowship Program, Recruiter, Instructor Writer, Training Developer

SFC: AIT Platoon Sergeant, Asymmetric Warfare Operational Support, CSA Strategic Studies Group, HQDA Strategic Broadening Seminar Program, White House Fellowship, Diver Liaison NCO, Instructor Writer, Combat Developer

MSG: CSA Strategic Studies Group, HQDA Strategic Broadening Seminar Program, White House Fellowship, Training Developer

CSM/SGM: N/A

Army wide Special Duty Assignments are specific, defined and provided in
the Annex to the Board MOI



MOS 12D



TRAINING

Most Qualified looks like:

SSG: Air Assault, Airborne, SHARP, MFT, MRT, EOL

SFC: Air Assault, Airborne, Joint Engineer Operations Course (JEOC), EOA, SHARP, MFT, MRT, IG

MSG: Air Assault, Airborne, Joint Engineer Operations Course (JEOC), EOA, SHARP, MFT, MRT, IG

CSM/SGM: N/A

Highly Qualified looks like:

SSG: First Class Divers Badge

SFC: Master Diver Badge

MSG: Master Diver Badge

CSM/SGM: N/A

OTHER INDICATORS

Most Qualified looks like:

SSG: Audie Murphy-SGT Morales (Active Member), Steel de Fleury Award, Sturgis Award, Army Combat Engineer Sergeant's Award, NCO of the Quarter/Year, Six Sigma Green Belt

SFC: Audie Murphy-SGT Morales (Active Member), Bronze de Fleury Award, Sturgis Award, NCO of the Quarter/Year, Project Management (ASI-P6), Lean Six Sigma Green Belt (ASI-1X)

MSG: Itschner Award, Bronze de Fleury Award, Battle Staff NCO Course, Project Management (ASI-P6), Six Sigma Black Belt, Audie Murphy-SGT Morales (Active Member)

CSM/SGM: N/A



MOS 12H



The Construction Engineering Supervisor serves as a member of a squad, section, or platoon. Duties start with supervising construction repair and utility service installation of buildings. The Construction Engineering Supervisor is responsible for concrete placement, culvert placement and installation; construction of fixed bridges; and directs and supervises demolition operations.

LEADERSHIP POSITIONS

Most Qualified looks like:

SSG: 18 months Construction Squad Leader, Construction Supervisor, Construction Engineer (SFAB) coupled with broadening assignment

SFC: 18 months Platoon Sergeant or Senior Construction Supervisor coupled with broadening assignment

MSG: N/A

CSM/SGM: N/A

Highly Qualified looks like:

SSG: 18 months Construction Squad Leader, Construction Supervisor, Construction Engineer (SFAB)

SFC: 18 months Platoon Sergeant or Senior Construction Supervisor

MSG: N/A

CSM/SGM: N/A



U.S. ARMY

MOS 12H



PHYSICAL FITNESS

Most Qualified looks like:

SSG: 270 or above or received the Army Physical Fitness Badge

SFC: 270 or above or received the Army Physical Fitness Badge

MSG: N/A

CSM/SGM: N/A

Highly Qualified looks like:

SSG: 250 – 269 on APFT

SFC: 250 – 269 on APFT

MSG: N/A

CSM/SGM: N/A

MILITARY/CIVILIAN EDUCATION

Most Qualified looks like:

SSG: ALC Distinguished Honor Graduate or Honor Graduate, AA Degree

SFC: SLC Distinguished Honor Graduate or Honor Graduate, Bachelors Degree

MSG: N/A

CSM/SGM: N/A

Highly Qualified looks like:

SSG: ALC Commandants List, Some College

SFC: SLC Commandants List, AA Degree

MSG: N/A

CSM/SGM: N/A



MOS 12H



ASSIGNMENTS (Broadening and Key Developmental)
PROPONENT SPECIFIC CHALLENGING / HIGH RISK

SSG: Drill Sergeant, AIT Platoon Sergeant, Security Force Assistance Brigade (SFAB), Defense Attaché System (DAS), White House Fellowship Program, Observer-Coach Trainer (OC/T), Recruiter, Instructor and Instructor/Writer

SFC: Senior Drill Sergeant, AIT Platoon Sergeant, Senior Construction Supervisor (FEST Team), Defense Attaché System (DAS), Security Force Assistance Brigade (SFAB), White House Fellowship, Observer-Coach Trainer (OC/T), Recruiter, Instructor and Instructor/Writer

MSG: N/A

CSM/SGM: N/A

Army wide Special Duty Assignments are specific, defined and provided in
the Annex to the Board MOI



MOS 12H



TRAINING

Most Qualified looks like:

SSG: Air Assault, Airborne, Jump Master, Ranger, SHARP, MFT, MRT, EOL

SFC: Air Assault, Airborne, Jump Master, Ranger, Joint Engineer Operations Course (JEOC), EOA, SHARP, MFT, MRT, IG

MSG: N/A

CSM/SGM: N/A

Highly Qualified looks like:

SSG: SHARP, MRT, EOL

SFC: SHARP, MRT, EOL

MSG: N/A

CSM/SGM: N/A

OTHER INDICATORS

Most Qualified looks like:

SSG: Audie Murphy-SGT Morales (Active Member), Steel de Fleury Award, Sturgis Award, Army Combat Engineer Sergeant's Award, NCO of the Quarter/Year, Six Sigma Green Belt, Senior Instructor Badge

SFC: Audie Murphy-SGT Morales (Active Member), Bronze de Fleury Award, Sturgis Award, NCO of the Quarter/Year, Project Management (ASI-P6), Lean Six Sigma Green Belt (ASI-1X), Master Instructor Badge

MSG: N/A

CSM/SGM: N/A



MOS 12M



The Firefighter supervises, directs, and performs firefighting operations during structural fires, aircraft crash incidents, vehicle emergencies, and natural cover fires. The Firefighter also supervises emergency response crews during hazardous materials (HAZMAT) incidents and conducts fire prevention operations to include determining building classification and installation level inspections.

LEADERSHIP POSITIONS

Most Qualified looks like:

SSG: 18 months Station Chief or Squad Leader coupled with broadening assignment

SFC: 18 months Detachment Fire Chief coupled with broadening assignment

MSG: N/A

CSM/SGM: N/A

Highly Qualified looks like:

SSG: 18 months Fire Team Chief

SFC: 18 months Detachment Fire Chief, BEB Fire Chief Observer-Coach/Trainer, or Instructor/Writer

MSG: N/A

CSM/SGM: N/A



U.S. ARMY

MOS 12M



PHYSICAL FITNESS

Most Qualified looks like:

SSG: 270 or above or received the Army Physical Fitness Badge

SFC: 270 or above or received the Army Physical Fitness Badge

MSG: N/A

CSM/SGM: N/A

Highly Qualified looks like:

SSG: 250 - 269 on APFT

SFC: 250 - 269 on APFT

MSG: N/A

CSM/SGM: N/A

MILITARY/CIVILIAN EDUCATION

Most Qualified looks like:

SSG: Fire Department Health and Safety Officer, EMT-B, AA Degree

SFC: Defense Support of Civil Authorities (DSCA) Phase I & II, EMT-B, Bachelors Degree

MSG: N/A

CSM/SGM: N/A

Highly Qualified looks like:

SSG: 12M ALC is non-standard; 12M's receive a met the standard rating on their 1059, Some College

SFC: 12M SLC is non-standard; 12M's receive a met the standard rating on their 1059, AA Degree

MSG: N/A

CSM/SGM: N/A



MOS 12M



ASSIGNMENTS (Broadening and Key Developmental)
PROPONENT SPECIFIC CHALLENGING / HIGH RISK

SSG: AIT Platoon Sergeant, Asymmetric Warfare Operational Support, Defense Attaché System (DAS), White House Fellowship Program, AIT Platoon Sergeant, Recruiter, and Instructor/Writer.

SFC: AIT Platoon Sergeant and BEB Fire Chief Observer-Coach/Trainer (OC/T), Sexual Assault Response Coordinator (SARC), Brigade Victim Advocate (VA), Equal Opportunity Advisor (EO), Assistant Inspector General, Asymmetric Warfare Operational Support, Asymmetric Warfare Operational Specialist, CSA Strategic Studies Group, HQDA Strategic Broadening Seminar Program, White House Fellowship, Instructor, and Instructor/Writer.

MSG: N/A

CSM/SGM: N/A

Army wide Special Duty Assignments are specific, defined and provided in
the Annex to the Board MOI



U.S. ARMY

MOS 12M



TRAINING

Most Qualified looks like:

SSG: Hazardous Materials Technician, Rescue Technician I, Emergency Medical Responder, Healthcare Provider CPR, National Incident Management System 300/400, Fire Instructor II, and Fire Inspector III, Airborne and Air Assault

SFC: Hazardous Materials Incident Commander, Emergency Medical Responder, Healthcare Provider CPR, National Incident Management System 300/400, Defense Support of Civil Authorities (DSCA) Phase I and II, Fire Instructor III, and Fire Inspector III, Master Fitness trainer, Battle Staff, Airborne and Air Assault

MSG: N/A

CSM/SGM: N/A

Highly Qualified looks like:

SSG: Air Assault, Airborne, Rappel Masters Course, Jump Master, SHARP, MRT, EOL

SFC: Air Assault, Airborne, Rappel Masters Course, Jump Master, SHARP, MRT, EOL

MSG: N/A

CSM/SGM: N/A

OTHER INDICATORS

Most Qualified looks like:

SSG: Audie Murphy-SGT Morales (Active Member), Steel de Fleury, Sturgis Award, ACES Award, NCO of the Quarter/Year, Six Sigma Green Belt

SFC: Audie Murphy-SGT Morales (Active Member), Bronze de Fleury, Sturgis Award, NCO of the Quarter/Year, Project Management (ASI-P6), Lean Six Sigma Green Belt (ASI-1X)

MSG: N/A

CSM/SGM: N/A



MOS 12N



The Horizontal Construction Engineer Supervisor serves as a member of a squad, section, or platoon. Duties start with operating heavy equipment at an apprentice level and progresses to construction equipment supervisor level. The Horizontal Construction Supervisor is responsible for construction projects, obstacle emplacement, and counter obstacle operations involving construction equipment.

LEADERSHIP POSITIONS

Most Qualified looks like:

- SSG: 18 months Squad Leader, Horizontal Construction Supervisor, Section Sergeant or Construction Foreman coupled with broadening assignment
- SFC: 18 months Platoon Sergeant, Senior Horizontal Construction Supervisor, Construction Inspector, Construction Equipment Supervisor, Operations Sergeant coupled with broadening assignment
- MSG: N/A
- CSM/SGM: N/A

Highly Qualified looks like:

- SSG: 18 months Squad Leader, Horizontal Construction Supervisor or Section Sergeant
- SFC: 18 months Platoon Sergeant or Senior Horizontal Construction Supervisor
- MSG: N/A
- CSM/SGM: N/A



U.S. ARMY

MOS 12N



PHYSICAL FITNESS

Most Qualified looks like:

SSG: 270 or above or received the Army Physical Fitness Badge; placed 5th or higher at Best Sapper

SFC: 270 or above or received the Army Physical Fitness Badge; placed 5th or higher at Best Sapper

MSG: N/A

CSM/SGM: N/A

Highly Qualified looks like:

SSG: 250 – 269 on APFT

SFC: 250 – 269 on APFT

MSG: N/A

CSM/SGM: N/A

MILITARY/CIVILIAN EDUCATION

Most Qualified looks like:

SSG: ALC Distinguished Honor Graduate or Honor Graduate, AA Degree

SFC: SLC Distinguished Honor Graduate or Honor Graduate, Bachelors Degree

MSG: N/A

CSM/SGM: N/A

Highly Qualified looks like:

SSG: ALC Commandants List, Some College

SFC: SLC Commandants List, AA Degree

MSG: N/A

CSM/SGM: N/A



MOS 12N



ASSIGNMENTS (Broadening and Key Developmental)
PROPONENT SPECIFIC CHALLENGING / HIGH RISK

SSG: Drill Sergeant, Asymmetric Warfare Operational Support, Defense Attaché System (DAS), Training With Industry (TWI) Program, Observer-Coach Trainer (OC/T), Small Group Leader (SGL), Recruiter, Instructor and Instructor/Writer

SFC: Career Management NCO (Proponent-USAES), Senior Drill Sergeant, Observer-Coach Trainer (OC/T), AIT Platoon Sergeant, Asymmetric Warfare Operational Support, Security Force Assistance Brigade (SFAB), Training With Industry (TWI) Program, White House Fellowship, Recruiter, Instructor and Instructor/Writer

MSG: N/A

CSM/SGM: N/A

Army wide Special Duty Assignments are specific, defined and provided in the Annex to the Board MOI



MOS 12N



TRAINING

Most Qualified looks like:

SSG: Air Assault, Airborne, Jump Master, Sapper, Ranger, SHARP, MFT, MRT, EOL
SFC: Air Assault, Airborne, Jump Master, Sapper, Ranger, Joint Engineer Operations Course (JEOC),
EOA, SHARP, MFT, MRT, IG
MSG: N/A
CSM/SGM: N/A

Highly Qualified looks like:

SSG: SHARP, MRT, EOL
SFC: SHARP, MRT, EOL
MSG: N/A
CSM/SGM: N/A

OTHER INDICATORS

Most Qualified looks like:

SSG: Audie Murphy-SGT Morales (Active Member), Steel de Fleury Award, Sturgis Award, Army
Combat Engineer Sergeant's Award, NCO of the Quarter/Year, Six Sigma Green Belt, Senior Instructor
Badge
SFC: Audie Murphy-SGT Morales (Active Member), Bronze de Fleury Award, Sturgis Award, NCO of
the Quarter/Year, Project Management (ASI-P6), Lean Six Sigma Green Belt (ASI-1X), Master
Instructor Badge
MSG: N/A
CSM/SGM: N/A



MOS 12P



The Prime Power Production Specialist serves as a member of a team, squad, section, or platoon performing electrical assessments, electrical facilities maintenance, QA/QC operations. Duties start with supervising, operating, installing, and performing organizational and sustainment level maintenance on electric power plants consisting of medium voltage power generation sets and associated auxiliary systems in support of overseas contingency bases, Forward Base Mode (FBM) sites, and Theatre High Altitude Air Defense System (THAADs) sites.

LEADERSHIP POSITIONS

Most Qualified looks like:

SSG: 18 months Senior Power Station Electrician, Senior Power Station Mechanic, Senior Power Station Instrumentation Technician, or Senior Power Plant Operator coupled with broadening assignment

SFC: 18 months Prime Power Supervisor, Intelligence Sergeant, Operations Sergeant, Senior Power Station Electrician or Senior Power Station Mechanic coupled with broadening assignment

MSG: N/A

CSM/SGM: N/A

Highly Qualified looks like:

SSG: 18 months Senior Power Station Electrician, Senior Power Station Mechanic, Senior Power Station Instrumentation Technician, or Senior Power Plant Operator

SFC: 18 months Prime Power Supervisor or Senior Power Station Electrician

MSG: N/A

CSM/SGM: N/A



U.S. ARMY

MOS 12P



PHYSICAL FITNESS

Most Qualified looks like:

SSG: 270 or above or received the Army Physical Fitness Badge

SFC: 270 or above or received the Army Physical Fitness Badge

MSG: N/A

CSM/SGM: N/A

Highly Qualified looks like:

SSG: 250 – 269 on APFT

SFC: 250 – 269 on APFT

MSG: N/A

CSM/SGM: N/A

MILITARY/CIVILIAN EDUCATION

Most Qualified looks like:

SSG: ALC Distinguished Honor Graduate or Honor Graduate, AA Degree

SFC: SLC Distinguished Honor Graduate or Honor Graduate, Bachelors Degree

MSG: N/A

CSM/SGM: N/A

Highly Qualified looks like:

SSG: ALC Commandants List, Some College

SFC: SLC Commandants List, AA Degree

MSG: N/A

CSM/SGM: N/A



MOS 12P



ASSIGNMENTS (Broadening and Key Developmental)
PROPONENT SPECIFIC CHALLENGING / HIGH RISK

SSG: Defense Attaché System (DAS), Recruiter, Instructor/Writer, Training Developer, and Facilities Project Coordinator. Recruiter, Instructor/Writer, Training Developer, and Facilities Project Coordinator

SFC: Sexual Assault Response Coordinator (SARC), Brigade Victim Advocate (VA), Equal Opportunity Advisor (EO), Assistant Inspector General, Asymmetric Warfare Operational Support, Asymmetric Warfare Operational Specialist, CSA Strategic Studies Group, HQDA Strategic Broadening Seminar Program, White House Fellowship, and Instructor/Writer

MSG: N/A

CSM/SGM: N/A

Army wide Special Duty Assignments are specific, defined and provided in
the Annex to the Board MOI



MOS 12P



TRAINING

Most Qualified looks like:

SSG: Air Assault, Airborne, Rappel Master, Jump Master, SHARP, MRT, EOL

SFC: Air Assault, Airborne, Rappel Master, Jump Master, SHARP, MRT, EOL

MSG: N/A

CSM/SGM: N/A

Highly Qualified looks like:

SSG: SHARP, MRT, EOL

SFC: SHARP, MRT, EOL

MSG: N/A

CSM/SGM: N/A

OTHER INDICATORS

Most Qualified looks like:

SSG: Audie Murphy-SGT Morales (Active Member), Steel de Fleury, Sturgis Award, ACES Award, NCO of the Quarter/Year, Six Sigma Green Belt, Senior Instructor Badge

SFC: Audie Murphy-SGT Morales (Active Member), Bronze de Fleury, Sturgis Award, NCO of the Quarter/Year, Project Management (ASI-P6), Lean Six Sigma Green Belt (ASI-1X), Master Instructor Badge

MSG: N/A

CSM/SGM: N/A



MOS 12T



The Technical Engineering Specialist participates in construction site development, to include technical investigation, surveying, and drafting. Develops construction plans and specifications, and performs quality control inspections.

LEADERSHIP POSITIONS

Most Qualified looks like:

SSG: 18 months Technical Engineer Squad Leader or Technical Topographic Survey NCO coupled with broadening assignment

SFC: 18 months Senior Technical Engineer NCO or Senior Technical Topographic Survey NCO coupled with broadening assignment

MSG: N/A

CSM/SGM: N/A

Highly Qualified looks like:

SSG: 18 months Technical Engineer Squad Leader

SFC: 18 months Senior Technical Engineer NCO

MSG: N/A

CSM/SGM: N/A



U.S. ARMY

MOS 12T



PHYSICAL FITNESS

Most Qualified looks like:

SSG: 270 or above or received the Army Physical Fitness Badge

SFC: 270 or above or received the Army Physical Fitness Badge

MSG: N/A

CSM/SGM: N/A

Highly Qualified looks like:

SSG: 250 – 269 on APFT

SFC: 250 – 269 on APFT

MSG: N/A

CSM/SGM: N/A

MILITARY/CIVILIAN EDUCATION

Most Qualified looks like:

SSG: ALC Distinguished Honor Graduate or Honor Graduate, AA Degree

SFC: SLC Distinguished Honor Graduate or Honor Graduate, Bachelors Degree

MSG: N/A

CSM/SGM: N/A

Highly Qualified looks like:

SSG: ALC Commandants List, Some College

SFC: SLC Commandants List, AA Degree

MSG: N/A

CSM/SGM: N/A



MOS 12T



ASSIGNMENTS (Broadening and Key Developmental)
PROPONENT SPECIFIC CHALLENGING / HIGH RISK

SSG: AIT Platoon Sergeant, Asymmetric Warfare Operational Support, Defense Attaché System (DAS), Security Force Assistance Brigade (SFAB), Small Group Leader (SGL), Instructor/Writer

SFC: AIT Platoon Sergeant, Sexual Assault Response Coordinator (SARC), Brigade Victim Advocate (VA), Equal Opportunity Advisor (EOA), Asymmetric Warfare Operational Support, Asymmetric Warfare Operational Specialist, CSA Strategic Studies Group, HQDA Strategic Broadening Seminar Program, White House Fellowship, Instructor/Writer and Senior Training Management NCO

MSG: N/A

CSM/SGM: N/A

Army wide Special Duty Assignments are specific, defined and provided in the Annex to the Board MOI



U.S. ARMY

MOS 12T



TRAINING

Most Qualified looks like:

SSG: Air Assault, Airborne, Jump Master, SHARP, MFT, MRT, EOL

SFC: Air Assault, Airborne, Jump Master, Joint Engineer Operations Course (JEOC), EOA, SHARP, MFT, MRT, Inspector General (IG)

MSG: N/A

CSM/SGM: N/A

Highly Qualified looks like:

SSG: SHARP, MRT, EOL

SFC: SHARP, MRT, EOL

MSG: N/A

CSM/SGM: N/A

OTHER INDICATORS

Most Qualified looks like:

SSG: Audie Murphy-SGT Morales (Active Member), Steel de Fleury Award, Sturgis Award, Army Combat Engineer Sergeant's Award, NCO of the Quarter/Year, Six Sigma Green Belt, Senior Instructor Badge

SFC: Audie Murphy-SGT Morales (Active Member), Bronze de Fleury Award, Sturgis Award, NCO of the Quarter/Year, Project Management (ASI-P6), Lean Six Sigma Green Belt (ASI-1X), Master Instructor Badge

MSG: N/A

CSM/SGM: N/A



MOS 12X



The General Engineering Supervisor supervises general engineering activities related to all construction and utility operations; assists Engineer Officers in construction planning, scheduling, and material estimates; provides staff supervision and principal NCO direction to units engaged in performing general engineering missions; inspects construction and training activities. In a company, a 12X First Sergeant is the senior enlisted Soldier in charge of the professional development, training, and welfare of the enlisted force in the company.

LEADERSHIP POSITIONS

Most Qualified looks like:

- SSG: N/A
- SFC: N/A
- MSG: 18 months First Sergeant coupled with broadening assignment
- CSM/SGM: N/A

Highly Qualified looks like:

- SSG: N/A
- SFC: N/A
- MSG: 18 months First Sergeant, Operations Sergeant, Power Station Sergeant, Construction Operations Sergeant, General Engineering Supervisor, Construction Inspector, and Maintenance Supervisor
- CSM/SGM: N/A



U.S. ARMY

MOS 12X



PHYSICAL FITNESS

Most Qualified looks like:

SSG: N/A

SFC: N/A

MSG: 270 or above or received the Army Physical Fitness Badge

CSM/SGM: N/A

Highly Qualified looks like:

SSG: N/A

SFC: N/A

MSG: 250 – 269 on APFT

CSM/SGM: N/A

MILITARY/CIVILIAN EDUCATION

Most Qualified looks like:

SSG: N/A

SFC: N/A

MSG: MLC Distinguished Honor Graduate or Honor Graduate, Bachelors Degree

CSM/SGM: N/A

Highly Qualified looks like:

SSG: N/A

SFC: N/A

MSG: MLC Commandants List, Associate's Degree

CSM/SGM: N/A



MOS 12X



ASSIGNMENTS (Broadening and Key Developmental)
PROPONENT SPECIFIC CHALLENGING / HIGH RISK

SSG: N/A

SFC: N/A

MSG: Senior Career Management NCO (Proponent-USAES), Brigade Engineer Battalion (BEB) Senior Construction Engineer Observer-Coach/Trainer (OC/T), First Sergeant (Security Force Assistance Brigade), Engineer NCOIC (Special Operations Command), Senior Instructor/Writer, Instructor/Writer and Senior Combat Development NCO

CSM/SGM: N/A

Army wide Special Duty Assignments are specific, defined and provided in the Annex to the Board MOI



U.S. ARMY

MOS 12X



TRAINING

Most Qualified looks like:

SSG: N/A

SFC: N/A

MSG: Air Assault, Airborne, Jumpmaster, Rappel Master, Battle Staff NCO, Ranger, Sapper, Joint Engineer Operations Course (JEOC), Master Fitness Trainer (MFT), Equal Opportunity Advisor (EOA), Sexual Harassment Assault Response Coordinator (SHARP), Master Resilience Training (MRT), Inspector General (IG)

CSM/SGM: N/A

Highly Qualified looks like:

SSG: N/A

SFC: N/A

MSG: N/A

CSM/SGM: N/A

OTHER INDICATORS

Most Qualified looks like:

SSG: N/A

SFC: N/A

MSG: Audie Murphy-SGT Morales (Active Member), Bronze de Fleury, Itschner Award, Project Management (ASI-P6), Six Sigma Black Belt

CSM/SGM: N/A



MOS 12Y



The Geospatial Engineer performs a variety of duties in support of their respective command. Soldiers at all levels perform duties ranging from data extraction (feature extraction from imagery), database management, along with supplying and managing Standard, Sharable, and Geospatial Foundation for the common operation picture. Geospatial Soldiers at the corps, division, and brigade levels also include a focus on operational and tactical level as part of the S2. Soldiers at this level also support the combatant commanders and their staffs with tactical decision aids and other GEOINT products in support of combat operations, disaster relief, and humanitarian support and treaty enforcement. ASCC level Geospatial Soldiers also contribute to GEOINT activities by forming cells within the G2 to support intelligence mission requirements.

LEADERSHIP POSITIONS

Most Qualified looks like:

SSG: 18 months Squad Leader or Senior Geospatial Engineer Sergeant with broadening assignment

SFC: 18 months Senior Geospatial Engineer Sergeant coupled with broadening assignment

MSG: 18 months Senior Geospatial Engineer Operations Sergeant with broadening assignment; those seeking First Sergeant opportunities should be uniquely qualified meriting additional consideration

CSM, SGM: Successfully served as CSM at 7C level for 24 months or SGM at 7S level for 36 months (nominative eligible)

Highly Qualified looks like:

SSG: 18 months Squad Leader or Senior Geospatial Engineer Sergeant

SFC: 18 months Senior Geospatial Engineer Sergeant

MSG: 18 months Senior Geospatial Engineer Operations Sergeant

CSM, SGM: Successfully served as CSM at 7C level for 18 months or SGM at 7S level for 12 months (nominative eligible)



U.S. ARMY

MOS 12Y



PHYSICAL FITNESS

Most Qualified looks like:

SSG: 270 or above or received the Army Physical Fitness Badge

SFC: 270 or above or received the Army Physical Fitness Badge

MSG: 270 or above or received the Army Physical Fitness Badge

CSM/SGM: 270 or above or received the Army Physical Fitness Badge

Highly Qualified looks like:

SSG: 250 – 269 on APFT

SFC: 250 – 269 on APFT

MSG: 250 – 269 on APFT

CSM/SGM: 250 - 269 on APFT

MILITARY, CIVILIAN EDUCATION

Most Qualified looks like:

SSG: ALC Distinguished Honor Graduate or Honor Graduate, AA Degree

SFC: SLC Distinguished Honor Graduate or Honor Graduate, Bachelors Degree

MSG: MLC Distinguished Honor Graduate or Honor Graduate, Bachelors Degree

CSM, SGM: USASMA Distinguished Honor Graduate or Honor Graduate, Masters Degree

Highly Qualified looks like:

SSG: ALC Commandants List, Some College

SFC: SLC Commandants List, AA Degree

MSG: MLC Commandants List, Three years College

CSM, SGM: USASMA Commandants List, Three Years College



MOS 12Y



ASSIGNMENTS (Broadening and Key Developmental) **PROPONENT SPECIFIC CHALLENGING , HIGH RISK**

SSG: Drill Sergeant, AIT Platoon Sergeant, Small Group Leader, Recruiter, Instructor, Instructor Writer, Training Developer, Asymmetric Warfare Group, Defense Attaché System, White House Fellowship Program

SFC: Senior Drill Sergeant, AIT Platoon Sergeant, Senior Small Group Leader, Small Group Leader, Instructor, Instructor Writer, Training Developer, Career Advisor NCO, Asymmetric Warfare Group, Defense Attaché System, White House Fellowship Program, CSA Strategic Studies Group, HQDA Strategic Broadening Seminar Program, Observer-Coach Trainer (OC/T)

MSG: Senior Instructor, Senior Career Management NCO (Proponent-USAES), Senior Combat Development NCO, Defense Attaché System, Asymmetric Warfare Group, White House Fellowship Program, CSA Strategic Studies Group, HQDA Strategic Broadening Seminar Program, Assistant Inspector General, Equal Opportunity Advisor (EO)

CSM, SGM: USASMA Fellowship/SGM or CSM positions in TRADOC Engineer or OSUT battalions and brigades

Army wide Special Duty Assignments are specific, defined and provided in the Annex to the Board MOI



MOS 12Y



TRAINING

Most Qualified looks like:

SSG: Airborne, Air Assault, Jumpmaster, Basic Combatives Instructor Course, Battle Staff, Rappel Master, Ranger, Master Fitness Trainer (MFT)

SFC: Airborne, Air Assault, Jumpmaster, Rappel Master, Ranger, Battle Staff, Combatives Instructor Course (Level IV), Joint Engineer Operations Course, MFT

MSG: Joint Engineer Operations Course, Battle Staff, MFT

CSM, SGM: Joint Engineer Operations Course (JEOC), Senior Enlisted Joint Professional Military Education (SEJPME) I-II Course

Highly Qualified looks like:

SSG: SHARP, MRT, EOL

SFC: SHARP, MRT, EOL

MSG: SHARP, MRT, EOL

CSM, SGM: Battle Staff

OTHER INDICATORS

Most Qualified looks like:

SSG: Audie Murphy-SGT Morales (Active Member), Steel de Fleury, Sturgis Award, ACES Award, NCO of the Quarter/Year, Six Sigma Green Belt, Senior Instructor Badge

SFC: Audie Murphy-SGT Morales (Active Member), Bronze de Fleury, Sturgis Award, NCO of the Quarter/Year, Project Management (ASI-P6), Lean Six Sigma Green Belt (ASI-1X), Geographic Information Systems Professional (GISP), Master Instructor Badge

MSG: Itschner Award, Project Management (ASI-P6), Six Sigma Black Belt, GISP

CSM/SGM: Project Management (ASI-P6), Lean Six Sigma Black Belt (ASI-1Y), GISP



MOS 12Z



Combat Engineering Senior Sergeant inspects and advises on bridging, rafting, and river crossing operations, formulates and maintains construction schedules. In a company an MOS 12Z 1SG is the senior enlisted Soldier in charge of the professional development, training and welfare of the enlisted force in the company. Advises engineer staff section personnel at battalion level and higher on matters involving combat engineer operations. Coordinates employment of engineer elements operating with the maneuver units. Inspects construction sites and enforces job specifications and safety standards. Collects, interprets, analyzes, evaluates, and disseminates intelligence data.

LEADERSHIP POSITIONS

Most Qualified looks like:

- SSG: N/A
- SFC: N/A
- MSG: 18 months First Sergeant coupled with broadening assignment
- CSM/SGM: N/A

Highly Qualified looks like:

- SSG: N/A
- SFC: N/A
- MSG: 18 months First Sergeant
- CSM/SGM: N/A



U.S. ARMY

MOS 12Z



PHYSICAL FITNESS

Most Qualified looks like:

SSG: N/A

SFC: N/A

MSG: 270 or above or received the Army Physical Fitness Badge

CSM/SGM: N/A

Highly Qualified looks like:

SSG: N/A

SFC: N/A

MSG: 250 – 269 on APFT

CSM/SGM: N/A

MILITARY/CIVILIAN EDUCATION

Most Qualified looks like:

SSG: N/A

SFC: N/A

MSG: MLC Distinguished Honor Graduate or Honor Graduate, Bachelors Degree

CSM/SGM: N/A

Highly Qualified looks like:

SSG: N/A

SFC: N/A

MSG: MLC Commandants List, three years College

CSM/SGM: N/A



MOS 12Z



ASSIGNMENTS (Broadening and Key Developmental)
PROPONENT SPECIFIC CHALLENGING / HIGH RISK

SSG: N/A

SFC: N/A

MSG: Sapper School Course Chief, Observer-Coach Trainer (OC/T), SFAB, EOA, SARC, Career Management NCO, Military Science Instructor, and Training Developer NCO

CSM/SGM: N/A

Army wide Special Duty Assignments are specific, defined and provided in
the Annex to the Board MOI



MOS 12Z



TRAINING

Most Qualified looks like:

SSG: N/A
SFC: N/A
MSG: Air Assault, Airborne, Rappel Master, Master Fitness Trainer, JEOC, MRT, SHARP, EOL
CSM/SGM: N/A

Highly Qualified looks like:

SSG: N/A
SFC: N/A
MSG: SHARP, MRT, EOL
CSM/SGM: N/A

OTHER INDICATORS

Most Qualified looks like:

SSG: N/A
SFC: N/A
MSG: Audie Murphy-SGT Morales (Active Member), Silver de Fleury, Project Management (ASI-P6), Six Sigma Black Belt
CSM/SGM: N/A