

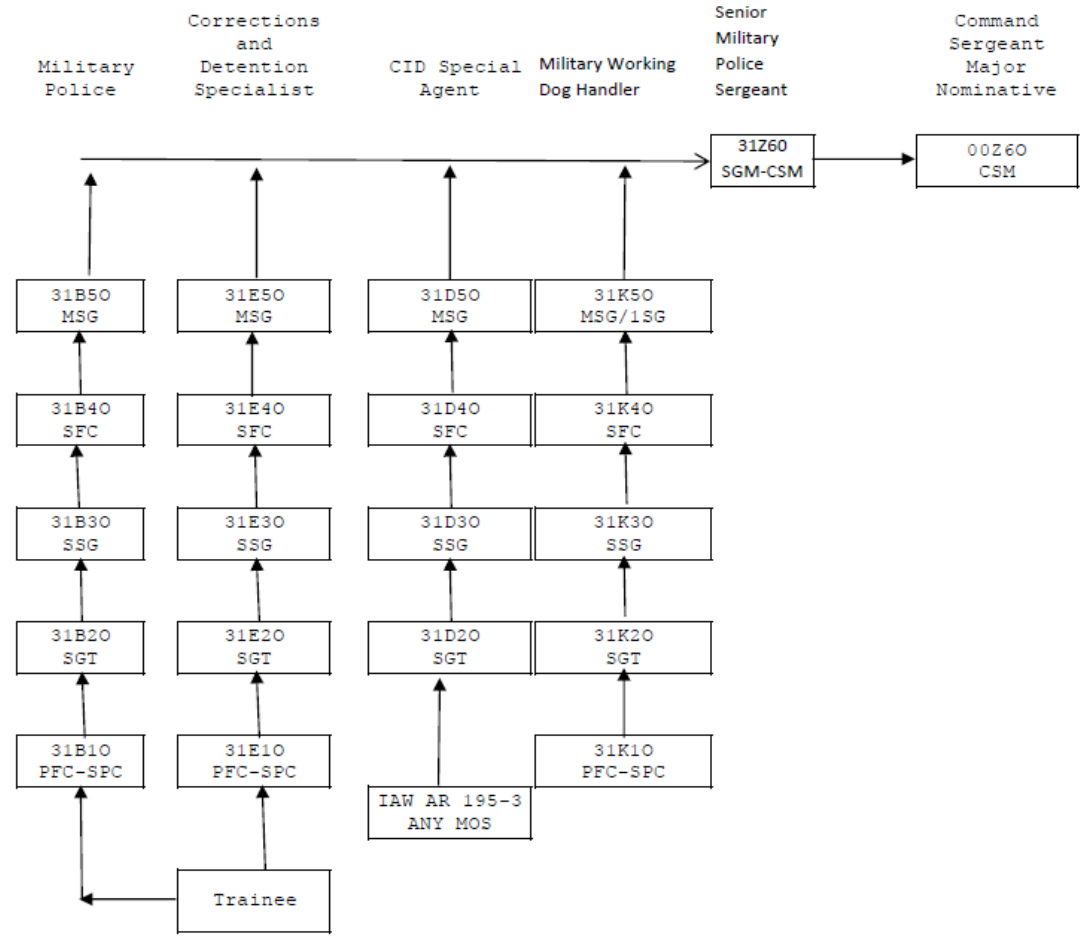

CMF 31 Progression Chart



SUBSTITUTABILITY: None.

→ Line of normal progression.

Figure 10-31. CMF 31 - Military Police career progression (Effective 202010)



MOS 31B



Military Police enable maneuver, protect the force, and shape the security environment by conducting police operations, detention and security, and mobility support across the full range of military operations in order to enable protection and promote the rule of law.

LEADERSHIP POSITIONS

Most qualified looks like:

SSG: Squad Leader for a 20 to 24 month period

SFC: Platoon Sergeant/Detachment Sergeant for 30 or more months

MSG: First Sergeant for a 30 or more months

Highly qualified looks like:

SSG: Squad Leader for 18 to 20 months

SFC: Platoon Sergeant/Detachment Sergeant for 24 to 30 months

MSG: First Sergeant for 24 to 30 months



MOS 31B



PHYSICAL FITNESS

Most qualified looks like:

SSG: GO on ACFT, MP Competitive Challenge Winner

SFC: GO on ACFT, MP Competitive Challenge Winner

MSG: GO on ACFT

Highly qualified looks like:

SSG: GO on ACFT

SFC: GO on ACFT

MSG: GO on ACFT

MILITARY/CIVILIAN EDUCATION

Most qualified looks like:

SSG: Associates Degree, Distinguished Honor Graduate/Leadership Awardee of ALC

SFC: Bachelors Degree, Distinguished Honor Graduate/Leadership Awardee of SLC

MSG: Bachelors Degree, Distinguished Honor Graduate/Leadership Awardee of MLC

Highly qualified looks like:

SSG: 30 College credit hours, ALC Commandants List

SFC: 60 College credit hours, SLC Commandants List

MSG: 90 College credit hours, MLC Commandants List



U.S. ARMY

MOS 31B



ASSIGNMENTS (Broadening and Key Developmental) **PROPONENT SPECIFIC CHALLENGING/HIGH RISK**

SSG: The Key and Developmental Assignment for a SSG is Squad Leader and should serve in the position for 24 months. Broadening assignments for a SSG are Drill Sergeant, Recruiter, Instructor/Writer, Small Group Leader, Military Science Instructor, System Development Manager, Project NCO, Observer Coach/Trainer, Training NCO, and Capabilities Division NCO (Futures Command).

SFC: The Key and Developmental Assignment for a SFC is Platoon Sergeant/Detachment Sergeant and should serve in the position for 30 months or more. Broadening assignments for a SFC are Drill Sergeant, Recruiter, Instructor/Writer, Career Management NCO, Small Group Leader, Observer Coach/Trainer, System Development NCO, Capabilities Division NCO (Futures Command), Capability Developer, Military Science Instructor, Talent Mgmt NCO, Tactical NCO, Senior Training Management NCO, and Training Developer.

MSG: The Key and Developmental Assignment for a MSG is First Sergeant and should serve in the position for 30 months or more. Broadening Assignments for a MSG are Senior PDNCO, Inspector General NCO, White House Fellowship, EO Advisor, and PSD NCO.



MOS 31B



TRAINING

Most qualified looks like:

- SSG: ALC, DLC II, SEJPME I, Military Police Investigator, Conventional Physical Security/Crime Prevention Course
- SFC: SLC, DLC III, SEJPME II, Battle Staff Course
- MSG: MLC, DLC IV, SEJPME II, Law Enforcement Senior Leaders Course

Highly qualified looks like:

- SSG: ALC, DLC II, Traffic Management and Collision Investigator
- SFC: SLC, DLC III, Conventional Physical Security/Crime Prevention Course
- MSG: MLC, DLC IV

OTHER INDICATORS

Most qualified looks like:

- SSG: Audie Murphy/SGT Morales member, NCO of the Year/Quarter, Order of the Marechaussee, Instructor Badge (Basic/Senior/Master), Recruiter Badge (Silver/Gold), Expert Solider Badge
- SFC: Audie Murphy/SGT Morales member, NCO of the Year/Quarter, Order of the Marechaussee, Instructor Badge (Basic/Senior/Master), Recruiter Badge (Silver/Gold), Expert Solider Badge
- MSG: Audie Murphy/SGT Morales member, NCO of the Year/Quarter, Order of the Marechaussee, Instructor Badge (Basic/Senior/Master), Recruiter Badge (Silver/Gold), Expert Solider Badge



MOS 31D



The CID Special Agent supervises or conducts investigations of incidents and offenses or allegations of criminality affecting DA or DoD personnel, property, facilities, or activities.

LEADERSHIP POSITIONS

Most qualified looks like:

SSG: Special Agent for a 20 to 24 month period

SFC: Detachment Sergeant for 30 or more months

MSG: First Sergeant for 30 or more months

Highly qualified looks like:

SSG: Special Agent for 18 to 20 months

SFC: Detachment Sergeant for 24 to 30 months

MSG: First Sergeant for 24 to 30 months



U.S. ARMY

MOS 31D



PHYSICAL FITNESS

Most qualified looks like:

SSG: GO on ACFT, MP Competitive Challenge Winner

SFC: GO on ACFT, MP Competitive Challenge Winner

MSG: GO on ACFT

Highly qualified looks like:

SSG: GO on ACFT

SFC: GO on ACFT

MSG: GO on ACFT

MILITARY/CIVILIAN EDUCATION

Most qualified looks like:

SSG: Associates Degree, Distinguished Honor Graduate/Leadership Awardee of ALC

SFC: Bachelors Degree, Distinguished Honor Graduate/Leadership Awardee of SLC

MSG: Bachelors Degree, Distinguished Honor Graduate/Leadership Awardee of MLC

Highly qualified looks like:

SSG: 80 College credit hours, ALC Commandants List

SFC: 90 College credit hours, SLC Commandants List

MSG: 110 College credit hours, MLC Commandants List



MOS 31D



ASSIGNMENTS (Broadening and Key Developmental) **PROPONENT SPECIFIC CHALLENGING/HIGH RISK**

SSG: The Key and Developmental Assignment for a SSG is CID Special Agent and should serve in the position for 24 months. Broadening assignments for a Small Group Leader and Instructor/Writer.

SFC: The Key and Developmental Assignment for a SFC is Detachment Sergeant and should serve in the position for 30 months or more. Broadening assignments for a SFC are Small Group Leader, Instructor/Writer, Talent Mgmt NCO, Training Developer NCO, System Development NCO, and Inspector General NCO.

MSG: The Key and Developmental Assignment for a MSG is First Sergeant and should serve in the position for 30 months or more. Broadening Assignments for a MSG are Assistant Inspector General, EO Advisor, and CID Enlisted Development NCO.

Army wide Special Duty Assignments are specific, defined and provided in
the Annex to the Board MOI



U.S. ARMY

MOS 31D



TRAINING

Most qualified looks like:

SSG: ALC, DLC II, SEJPME I, Protective Services Training

SFC: SLC, DLC III, SEJPME II, Crime and Criminal Analyst Course

MSG: MLC, DLC IV, SEJPME II, Law Enforcement Senior Leaders Course

Highly Qualified looks like:

SSG: ALC, DLC II, Domestic Violence Intervention Training

SFC: SLC, DLC III, Child Abuse Prevention Investigative Techniques

MSG: MLC, DLC IV, Advanced Crime Scene Investigation Techniques Course

OTHER INDICATORS

Most qualified looks like:

SSG: Audie Murphy/SGT Morales member, NCO of the Year/Quarter, Order of the Marechaussee, Instructor Badge (Basic/Senior/Master), Expert Solider Badge

SFC: Audie Murphy/SGT Morales member, NCO of the Year/Quarter, Order of the Marechaussee, Instructor Badge (Basic/Senior/Master), Expert Solider Badge

MSG: Audie Murphy/SGT Morales member, NCO of the Year/Quarter, Order of the Marechaussee, Instructor Badge (Basic/Senior/Master), Expert Solider Badge



MOS 31E



The Correction/Detention (C/D) Specialist in CONUS operations provides exemplarily custody and control of U.S. military inmates located at the two Regional Correctional Facilities and the United States Disciplinary Barracks. OCONUS, C/D Specialists delivers humane, legal, and thorough detainee operations at an unparalleled level of expertise to all overseas contingency operations.

LEADERSHIP POSITIONS

Most qualified looks like:

SSG: Squad Leader for a 20 to 24 month period

SFC: Platoon Sergeant for a 30 or more months

MSG: First Sergeant for a for a 30 or more months

Highly qualified looks like:

SSG: Squad Leader for 18 to 20 months

SFC: Platoon Sergeant for 24 to 30 months

MSG: First Sergeant for 24 to 30 months



MOS 31E



PHYSICAL FITNESS

Most qualified looks like:

- SSG: GO on ACFT, MP Competitive Challenge Winner
- SFC: GO on ACFT, MP Competitive Challenge Winner
- MSG: GO on ACFT

Highly qualified looks like:

- SSG: GO on ACFT
- SFC: GO on ACFT
- MSG: GO on ACFT

MILITARY/CIVILIAN EDUCATION

Most qualified looks like:

- SSG: Associates Degree, Distinguished Honor Graduate/Leadership Awardee of ALC
- SFC: Bachelors Degree, Distinguished Honor Graduate/Leadership Awardee of SLC
- MSG: Bachelors Degree, Distinguished Honor Graduate/Leadership Awardee of MLC

Highly qualified looks like:

- SSG: 30 College credit hours, ALC Commandants List
- SFC: 60 College credit hours, SLC Commandants List
- MSG: 90 College credit hours, MLC Commandants List



MOS 31E



ASSIGNMENTS (Broadening and Key Developmental) PROPONENT SPECIFIC CHALLENGING/HIGH RISK

SSG: The Key and Developmental Assignment for a SSG is Squad Leader and should serve in the position for 24 months. Broadening assignments for a SSG are Drill Sergeant, Instructor, Small Group Leader, Observer Coach/Trainer, Corrections Supervisor, ACA Plans and Policy NCO, Corrections Liaison, MP Investigator Supervisor, and Housing Unit NCOIC.

SFC: The Key and Developmental Assignment for a SFC is Platoon Sergeant and should serve in the position for 30 months or more. Broadening assignments for a SFC are Drill Sergeant, Instructor, Small Group Leader, Observer Coach/Trainer, Talent Mgmt NCO, Training Developer, System Development NCO, Prisoner Services/Admin NCO, Corrections Supervisor, and Plans NCO.

MSG: The Key and Developmental Assignment for a MSG is First Sergeant and should serve in the position for 30 months or more. Broadening Assignments for a MSG are Senior Career Management NCO, Inspector General NCO, Training with Industry, and BN/BDE Operations.

Army wide Special Duty Assignments are specific, defined and provided in
the Annex to the Board MOI



MOS 31E



TRAINING

Most qualified looks like:

- SSG: ALC, DLC II, SEJPME I, Anti-Terrorism Officer (Advanced) Course
- SFC: SLC, DLC III, SEJPME II, Battle Staff Course
- MSG: MLC, DLC IV, SEJPME II, Law Enforcement Senior Leaders Course

Highly Qualified looks like:

- SSG: ALC, DLC II, Special Reaction Team
- SFC: SLC, DLC III, Conventional Physical Security/Crime Prevention Course
- MSG: MLC, DLC IV

OTHER INDICATORS

Most qualified looks like:

- SSG: Audie Murphy/SGT Morales member, NCO of the Year/Quarter, Order of the Marechaussee, Instructor Badge (Basic/Senior/Master), and Recruiter Badge (Silver/Gold), Expert Solider Badge
- SFC: Audie Murphy/SGT Morales member, NCO of the Year/Quarter, Order of the Marechaussee, Instructor Badge (Basic/Senior/Master), and Recruiter Badge (Silver/Gold), Expert Solider Badge
- MSG: Audie Murphy/SGT Morales member, NCO of the Year/Quarter, Order of the Marechaussee, Instructor Badge (Basic/Senior/Master), and Recruiter Badge (Silver/Gold), Expert Solider Badge



MOS 31K



Military Working Dog (MWD) teams support joint forces in offensive, defensive, and stability tasks, contributes to the preservation of combat power, and enable the security environment on the battlefield and at post/camp/station. MWD teams accomplish their mission by providing target odor detection (explosive/drug) and a less than lethal course of action that serves as a psychological deterrent. Patrol Drug Detector Dog (PDDD), Patrol Explosive Detector Dog (PEDD), and Patrol Explosive Detector Dog – Enhanced (PEDD-E) teams provide installation and maneuver commanders the ability to detect and locate hidden personnel, illicit drugs and paraphernalia, weapons, ammunition, explosive ordnance, and improvised explosive devices (IED).

LEADERSHIP POSITIONS

Most qualified looks like:

SSG: Squad Leader for a 20 to 24 month period

SFC: Kennel Master for 30 or more months

MSG: First Sergeant or MWD Program Manager for 30 or more months

Highly qualified looks like:

SSG: Squad Leader for 18 to 20 months

SFC: Kennel Master for 24 to 30 months

MSG: First Sergeant or MWD Program Manager for 24 to 30 months



MOS 31K



PHYSICAL FITNESS

Most qualified looks like:

- SSG: GO on ACFT, MP Competitive Challenge Winner
- SFC: GO on ACFT, MP Competitive Challenge Winner
- MSG: GO on ACFT

Highly qualified looks like:

- SSG: GO on ACFT
- SFC: GO on ACFT
- MSG: GO on ACFT

MILITARY/CIVILIAN EDUCATION

Most qualified looks like:

- SSG: Associates Degree, Distinguished Honor Graduate/Leadership Awardee of ALC
- SFC: Bachelors Degree, Distinguished Honor Graduate/Leadership Awardee of SLC
- MSG: Bachelors Degree, Distinguished Honor Graduate/Leadership Awardee of MLC

Highly qualified looks like:

- SSG: 30 College credit hours, ALC Commandants List
- SFC: 60 College credit hours, SLC Commandants List
- MSG: 90 College credit hours, MLC Commandants List



MOS 31K



ASSIGNMENTS (Broadening and Key Developmental) PROPONENT SPECIFIC CHALLENGING/HIGH RISK

SSG: The Key and Developmental Assignment for a SSG is Squad Leader and should serve in the position for 24 months. Broadening assignments for a SSG are Drill Sergeant, Instructor, Small Group Leader, MWD Trainer, and MWD Handler Observer Coach/Trainer.

SFC: The Key and Developmental Assignment for a SFC is Kennel Master and should serve in the position for 30 months or more. Broadening assignments for a SFC are Drill Sergeant, Instructor, Small Group Leader, MWD Trainer, Talent Management NCO, Senior Training MGMT NCO (MWD), and Multi-Purpose Canine Program Manager.

MSG: The Key and Developmental Assignment for a MSG is First Sergeant and MWD Program Manager and should serve in the position for 30 months or more. Broadening Assignments for a MSG are MWD Career Management NCO, Training Development NCO (MWD), and Senior Training Developer.



MOS 31K



TRAINING

Most qualified looks like:

SSG: ALC, DLC II, SEJPME I, MWD Trainer/Kennel Master Course

SFC: SLC, DLC III, SEJPME II, Battle Staff, MWD Trainer/Kennel Master Course

MSG: MLC, DLC IV, SEJPME II, Capabilities Development Course

Highly Qualified looks like:

SSG: ALC, DLC II, Anti Terrorism Officer (Basic) Course

SFC: SLC, DLC III, Conventional Physical Security/Crime Prevention Course

MSG: MLC, DLC IV, Law Enforcement Senior Leaders Course

OTHER INDICATORS

Most qualified looks like:

SSG: Audie Murphy/SGT Morales member, NCO of the Year/Quarter, Order of the Marechaussee, and Instructor Badge (Basic Senior/Master), Expert Solider Badge

SFC: Audie Murphy/SGT Morales member, NCO of the Year/Quarter, Order of the Marechaussee, and Instructor Badge (Basic/Senior/Master), Expert Solider Badge

MSG: Audie Murphy/SGT Morales member, NCO of the Year/Quarter, Order of the Marechaussee, and Instructor Badge (Basic/Senior/Master), Expert Solider Badge



MOS 31Z



Senior Military Police Sergeant is responsible for supervising the manning, training, equipping and combat readiness of a Battalion and Brigade/Group level of command; principle staff NCO in operations whom plans, coordinates and manages Battalion and Brigade/Group operations, training and tasking's to provide Police Operations; Corrections and Detention, Security and Mobility support and Criminal Investigations.

LEADERSHIP POSITIONS

Most qualified looks like:

SGM/CSM: CSM for 30 to 36 month period

Highly qualified looks like:

SGM/CSM: CSM for 24 to 30 months



MOS 31Z



PHYSICAL FITNESS

Most qualified looks like:

SGM/CSM: GO on ACFT

Highly qualified looks like:

SGM/CSM: GO on ACFT

MILITARY/CIVILIAN EDUCATION

Most qualified looks like:

SGM/CSM: Master Degree, Distinguished Honor Graduate/Leadership Awardee of USASMA

Highly qualified looks like:

SGM/CSM: Bachelors Degree, USASMA Commandants List



MOS 31Z



ASSIGNMENTS (Broadening and Key Developmental) **PROPONENT SPECIFIC CHALLENGING/HIGH RISK**

SGM/CSM: The Key Leadership Assignment for a 31Z is Battalion/Brigade/Group CSM and should serve in the position for a minimum for 30 months. Key Developmental Assignment for a 31Z is Battalion/Brigade/Group Operations Sergeant Major, Facility SGM, DES SGM, Chief Career Management NCO, G2/G3 Sergeant Major at CID Headquarters, MDW Provost SGM, and TRADOC/FORSCOM/IMCOM/USAREUR-AF/USARPAC Provost NCO. Broadening assignments for a SGM/CSM is Directorate of Training (USAMPS) SGM, Directorate of Plans and Operations (USAMPS) SGM, Basic Military Police Training Division (USAMPS) SGM, NCOA Assistant Commandant (MSCOE), Observer-Coach CSM (2x BN CSM OCT), Enlisted MP Branch SGM, Military Working Dog Program SGM, USASMA Small Group Leader, and USASMA Fellowship positions and should serve in the position for 24 months.



U.S. ARMY

MOS 31Z



TRAINING

Most qualified looks like:

SGM/CSM: DLC VI, Law Enforcement Senior Leaders Course,

Highly Qualified looks like:

SGM/CSM: Military Police Pre-Command Course

OTHER INDICATORS

Most qualified looks like:

SGM/CSM: Audie Murphy/SGT Morales member and Order of the Marechausee