



# HANDBOOK



No. 15-06

MAR 15

# MDMP



*Lessons and Best Practices*

Approved for Public Release  
Distribution Unlimited



CENTER FOR ARMY LESSONS LEARNED

---

SUPPORTING THE WARFIGHTER



# Military Decisionmaking Process

## **DIGITAL VERSION AVAILABLE**

A digital version of this CALL publication is available to view, download, or reproduce from the CALL restricted website, <<https://call2.army.mil>>. Reproduction of this publication is welcomed and highly encouraged.

Common Access Card (CAC) or Army Knowledge Online (AKO) login is required to access the digital version.





## Foreword

Historically, a unit's success is directly related to the ability of the staff to execute the military decisionmaking process (MDMP). Given the increased complexity of today's operational environment and the vast array of mission command systems and processes, integration and synchronization of all activities associated with operations are increasingly difficult.

Observations derived from deployed units, as well as from trainers at Combat Training Centers (CTCs) over the past decade, indicate a significant loss of unit ability to conduct a detailed MDMP. This lack of planning expertise results in de-synchronized operations, and could ultimately cost the lives of Soldiers.

Both in actual operations and in training at the CTCs, planning time is often extremely limited. In these instances, units often omit steps of the MDMP. Most CTC trainers agree that when time is limited, completely omitting any step of the MDMP is not the solution and often degrades mission success. Combat operations in Iraq and Afghanistan resulted in the use of non-doctrinal story boards in the planning process. This practice lacks the fidelity necessary to provide the commander with decisionmaking information he needs, and can lead to a loss of synchronization during operations.

The MDMP is a solid model for developing a solution to a problem. However, if the staff conducting the MDMP is unfamiliar with each of the steps, the process can become very complex, and errors committed early in the process become increasingly problematic as planning continues.

The MDMP facilitates interaction among the commander, staff, and subordinate headquarters throughout the operations process. It provides a structure for the staff to work collectively and produce a coordinated plan. During planning, staff members monitor, track, and aggressively seek information important to their functional areas. They assess how this information affects course of action development and apply it to any recommendations they make.

There are numerous key doctrinal manuals that address MDMP. **This handbook is designed to consolidate much of this doctrine, combined with analysis of observations from recent deployments and CTC rotations, into a single source that is useful to junior leaders as they conduct the MDMP.** More detailed study of the MDMP can be accomplished by studying the key doctrinal manuals listed in Chapter 13 of this handbook.

A handwritten signature in black ink that reads "Paul P. Reese". The signature is written in a cursive style with a large, prominent initial "P".

Paul P. Reese  
COL, AR  
Director, Center for Army Lessons Learned

<b>Military Decisionmaking Process</b>	
<b>Table of Contents</b>	
<b>Introduction</b>	<b>1</b>
<b>Chapter 1. Army Design Methodology</b>	<b>3</b>
<b>Chapter 2. Military Decisionmaking Process</b>	<b>7</b>
<b>Chapter 3. Receipt of Mission</b>	<b>9</b>
<b>Chapter 4. Mission Analysis</b>	<b>11</b>
<b>Chapter 5. Course of Action Development</b>	<b>27</b>
<b>Chapter 6. Course of Action Analysis</b>	<b>39</b>
<b>Chapter 7. Course of Action Comparison</b>	<b>59</b>
<b>Chapter 8. Course of Action Approval</b>	<b>63</b>
<b>Chapter 9. Assessments</b>	<b>65</b>
<b>Chapter 10. Operations Order</b>	<b>71</b>
<b>Chapter 11. Rehearsals</b>	<b>83</b>
<b>Chapter 12. Terminology</b>	<b>97</b>
<b>Chapter 13. References</b>	<b>103</b>

<b>Center For Army Lessons Learned</b>	
<b>Director</b>	<b>COL Paul P. Reese</b>
<b>Deputy Division Chief</b>	<b>Mr. George J. Mordica II</b>
<b>CALL Lead Analyst</b>	<b>Mr. Jeff Baker</b>
<b>CALL Contributing Analyst</b>	<b>Mr. James Cameron</b>
<b>Project Analyst</b>	<b>Mr. Mike Flynn Combined Arms Doctrine Directorate</b>

The Secretary of the Army has determined that the publication of this periodical is necessary in the transaction of the public business as required by law of the Department.

Unless otherwise stated, whenever the masculine or feminine gender is used, both are intended.

**Note:** Any publications (other than CALL publications) referenced in this product, such as ARs, FMs, and TMs, must be obtained through your pinpoint distribution system.



## Introduction

“A good plan violently executed now is better than a perfect plan executed next week.”

— General George S. Patton

Planning is the art and science of understanding a situation, envisioning a desired future, and laying out effective ways of bringing that future about. Planning helps commanders create and communicate a common vision among themselves, their staffs, subordinate commanders, and unified action partners.

All planning is based on imperfect knowledge and assumptions about the future. Planning cannot predict exactly what the effects of the operation will be, how enemies will behave, or how civilians will respond to the friendly force or the enemy. Nonetheless, the understanding and learning that occur during the planning process have great value.

Planning activities occupy a continuum ranging from conceptual to detailed. On one end of the continuum is conceptual planning. Understanding the operational environment and the problem, determining the operation's end state, establishing objectives, and sequencing the operation in broad terms all illustrate conceptual planning.

At the other end of the spectrum is detailed planning. Detailed planning translates the broad operational approach into a complete and practical plan. Detailed planning works out the scheduling, coordination, or technical problems involved with moving, sustaining, synchronizing, and directing the force.

Army leaders employ three methodologies for planning, determining the appropriate mix based on the scope of the problem and their familiarity with it, the time available, and the availability of a staff. Methodologies that assist commanders and staffs with planning include Army design methodology, the military decisionmaking process (MDMP), and troop leading procedures.

This handbook will provide a brief discussion of the Army design methodology and how it is integrated with and complements the MDMP, but the focus of this handbook is to provide commanders and their staffs a tool to assist in the understanding and implementation of MDMP.



# Chapter 1

## Army Design Methodology

This chapter is designed to give a brief explanation of the Army design methodology and how it is integrated with the military decisionmaking process (MDMP). For a more detailed explanation of the Army design methodology, refer to ADP 5-0 and ADRP 5-0.

Army design methodology is a methodology for applying critical and creative thinking to understand, visualize, and describe problems and approaches to solving them (ADRP 5-0). Army design methodology is particularly useful as an aid to conceptual planning, but must be integrated with the detailed planning typically associated with the MDMP to produce executable plans.

Army design methodology entails framing an operational environment, framing a problem, and developing an operational approach to solve the problem. It results in an improved understanding of the operational environment, a problem statement, the initial commander’s intent, and an operational approach that serves as the link between conceptual and detailed planning. Based on their understanding gained during the Army design methodology, commanders issue planning guidance, to include an operational approach, to guide more detailed planning using the MDMP.

Figure 1-1 depicts the general activities of Army design methodology. While planners complete some activities before others, the learning generated in one activity may require revisiting the learning derived in another activity.

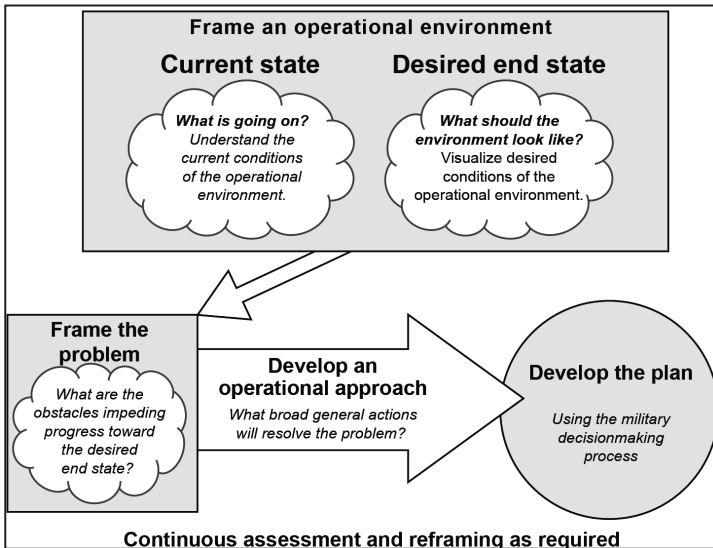

Figure 1-1. Frame the operational environment (ADRP 5-0)

## **Frame the Operational Environment**

The commander, members of the staff, subordinate commanders, and unified action partners form a planning team to establish context for describing the problem and developing an operational approach by framing an operational environment. This framing facilitates hypothesizing, or modeling, that focuses on the part of the operational environment under consideration. Framing provides a perspective from which commanders can understand and act on a problem.

In framing an operational environment, the planning team focuses on defining, analyzing, and synthesizing the characteristics of the operational and mission variables. Members of the planning team capture their work in an operational environmental frame (using narrative and visual models) that describes and depicts the history, culture, current state, relationships, and future goals of relevant actors in an operational environment. An operational environmental frame consists of two parts — the current state of the operational environment and the desired end state of the operational environment.

## **Frame the Problem**

A problem is an issue or obstacle that makes it difficult to achieve a desired goal or objective. In the context of operations, an operational problem is the issue or set of issues that impede commanders from achieving their desired end state. Problem framing involves identifying and understanding those issues that impede progress toward the desired end state.

Members of the planning team frame the problem to ensure that they are solving the right problem, instead of solving symptoms of the problem. Framing the problem involves understanding and isolating the root causes of conflict. The planning team closely examines the symptoms, the underlying tensions, and the root causes of conflict. From this perspective, the planning team can identify the fundamental problem with greater clarity and consider more accurately how to solve it. A technique for framing the problem begins with two basic questions:

- What is the difference between the current state and the desired state of the operational environment?
- What is preventing U.S. forces from reaching the desired end state?

Based on the problem frame, the planning team develops a problem statement — a concise statement of the issue or issues requiring resolution.

## **Develop an Operational Approach**

Based on their understanding of the operational environment and the problem, the planning team members consider operational approaches — the broad general actions — to solve the problem. The operational approach serves as the main idea that informs detailed planning and guides the force through preparation and execution.

The planning team uses the elements of operational art (see ADRP 3-0) to help think through the operational environment and visualize and describe the operational approach. As the planning team considers various approaches, it evaluates the types of defeat or stability mechanisms that may lead to conditions that define the desired end state. Thus, the operational approach enables commanders to begin visualizing and describing possible combinations of actions to reach the desired end state, given the tensions identified in the operational environment and problem frames. The staff uses operational approaches to develop courses of action during detailed planning.

Planners can depict the operational approach by using lines of effort that graphically articulate the links among tasks, objectives, conditions, and the desired end state. Army design methodology offers the latitude to portray the operational approach in a manner that best communicates its vision and structure. Ultimately, the commander determines the optimal method to articulate the operational approach. However, it is important that narratives accompany lines of effort to ensure that subordinate commanders and Soldiers understand the operational approach.

## **Document Results**

Commanders and staffs document the results of Army design methodology to inform more detailed planning. Key outputs of Army design methodology conveyed in text and graphics include the problem statement, initial commander's intent, and planning guidance to include an operational approach.

The problem statement generated during problem framing communicates the commander's understanding of the problem or problem set upon which the organization will act. The initial commander's intent describes the purpose of the operation, initial key tasks, and the desired end state. The operational approach organizes combinations of potential actions in time, space, and purpose that will guide the force to the desired end state. Planning guidance orients the focus of operations, linking desired conditions to potential combinations of actions the force may employ to achieve the desired end state.

## **Reframing**

Through continuous assessment, the commander and staff monitor the operational environment and progress toward setting conditions and achieving objectives. If the current operational approach is failing to meet expectations, or if aspects of the operational environment or problem change significantly, the commander may decide to begin reframing efforts.

During operations, commanders decide to reframe after realizing that the desired conditions have changed, are not achievable, or cannot be attained through the current operational approach, or because of change of mission or end state. Reframing provides the freedom to operate beyond the limits of any single perspective. Conditions will change during execution, and such change is expected because forces interact within the operational environment. Recognizing and anticipating these changes is fundamental to Army design methodology and essential to an organization's ability to learn.

## Chapter 2

### Military Decisionmaking Process

The MDMP is an iterative planning methodology that integrates the activities of the commander, staff, subordinate headquarters, and other partners to understand the situation and mission, develop and compare courses of action (COAs), decide on a COA that best accomplishes the mission, and produce an operation plan or order for execution. The MDMP helps leaders apply thoroughness, clarity, sound judgment, logic, and professional knowledge to understand situations, develop options to solve problems, and reach decisions. The MDMP is a process that helps commanders, staffs, and others think critically and creatively while planning.

The MDMP facilitates collaborative and parallel planning as the higher headquarters solicits input and continuously shares information concerning future operations with subordinate and adjacent units, supporting and supported units, and other military and civilian partners through planning meetings, warning orders (WARNORDs), and other means. Commanders encourage active collaboration among all organizations affected by the pending operations to build a shared understanding of the situation, participate in COA development and decision making, and resolve conflicts before publication of the plan or order.

The MDMP also drives preparation. Since time is a factor in all operations, commanders and staffs conduct a time analysis early in the planning process. This analysis helps them determine what actions are required and when those actions must begin to ensure forces are ready and in position before execution. This may require the commander to direct subordinates to start necessary movements; conduct task organization changes; begin information collection operations; and execute other preparation activities before completing the plan. The commander directs these tasks in a series of WARNORDs as the commander and staff conduct the MDMP.

During planning, assessment focuses on developing an understanding of the current situation, ascertaining what to assess, and determining how to assess progress using measures of effectiveness and measures of performance.

Developing the unit's assessment plan occurs during the MDMP — not after the plan or order is developed.

Key inputs	Steps	Key outputs
<ul style="list-style-type: none"> <li>Higher headquarters' plan or order or a new mission anticipated by the commander</li> </ul>	<p>Step 1: <b>Receipt of Mission</b></p>	<ul style="list-style-type: none"> <li>Commander's initial guidance</li> <li>Initial allocation of time</li> </ul>
Warning order		
<ul style="list-style-type: none"> <li>Commander's initial guidance</li> <li>Higher headquarters' plan or order</li> <li>Higher headquarters' knowledge and intelligence products</li> <li>Knowledge products from other organizations</li> <li>Army design methodology products</li> </ul>	<p>Step 2: <b>Mission Analysis</b></p>	<ul style="list-style-type: none"> <li>Problem statement</li> <li>Mission statement</li> <li>Initial commander's intent</li> <li>Initial planning guidance</li> <li>Initial CCIRs and EEFI</li> <li>Updated IPB and running estimates</li> <li>Assumptions</li> <li>Evaluation criteria for COAs</li> </ul>
Warning order		
<ul style="list-style-type: none"> <li>Mission statement</li> <li>Initial commander's intent, planning guidance, CCIRs, and EEFI</li> <li>Updated IPB and running estimates</li> <li>Assumptions</li> <li>Evaluation criteria for COAs</li> </ul>	<p>Step 3: <b>Course of Action (COA) Development</b></p>	<ul style="list-style-type: none"> <li>COA statements and sketches                             <ul style="list-style-type: none"> <li>Tentative task organization</li> <li>Broad concept of operations</li> </ul> </li> <li>Revised planning guidance</li> <li>Updated assumptions</li> </ul>
<ul style="list-style-type: none"> <li>Updated running estimates</li> <li>Revised planning guidance</li> <li>COA statements and sketches</li> <li>Updated assumptions</li> </ul>	<p>Step 4: <b>COA Analysis (War Game)</b></p>	<ul style="list-style-type: none"> <li>Refined COAs</li> <li>Potential decision points</li> <li>War-game results</li> <li>Initial assessment measures</li> <li>Updated assumptions</li> </ul>
<ul style="list-style-type: none"> <li>Updated running estimates</li> <li>Refined COAs</li> <li>Evaluation criteria</li> <li>War-game results</li> <li>Updated assumptions</li> </ul>	<p>Step 5: <b>COA Comparison</b></p>	<ul style="list-style-type: none"> <li>Evaluated COAs</li> <li>Recommended COAs</li> <li>Updated running estimates</li> <li>Updated assumptions</li> </ul>
<ul style="list-style-type: none"> <li>Updated running estimates</li> <li>Evaluated COAs</li> <li>Recommended COA</li> <li>Updated assumptions</li> </ul>	<p>Step 6: <b>COA Approval</b></p>	<ul style="list-style-type: none"> <li>Commander approved COA and any modifications</li> <li>Refined commander's intent, CCIRs, and EEFI</li> <li>Updated assumptions</li> </ul>
Warning order		
<ul style="list-style-type: none"> <li>Commander approved COA and any modifications</li> <li>Refined commander's intent, CCIRs, and EEFI</li> <li>Updated assumptions</li> </ul>	<p>Step 7: <b>Orders Production, Dissemination, and Transition</b></p>	<ul style="list-style-type: none"> <li>Approved operations plan or order</li> <li>Subordinates understand the plan or order</li> </ul>
<p>CCIR commander's critical information requirement</p>	<p>EEFI essential element of friendly information</p>	<p>IPB intelligence preparation of the battlefield</p>
<p>COA course of action</p>		

Figure 2-1. Military decisionmaking process (FM 6-0)



## Chapter 3

### Receipt of Mission

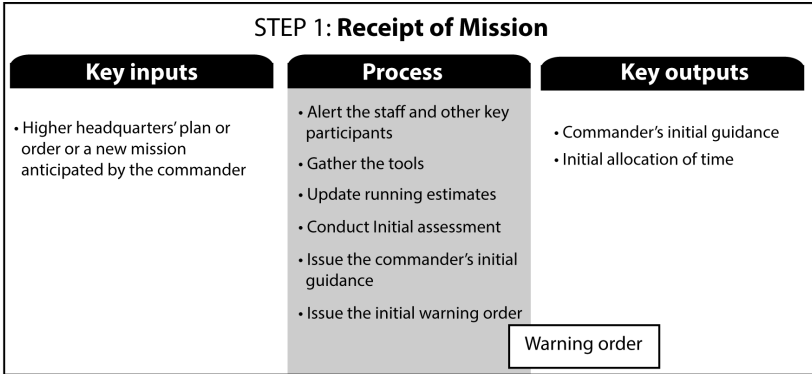

**Figure 3-1. Receipt of Mission (Ref: FM 6-0)**

Commanders initiate the MDMP upon receipt or in anticipation of a mission. The purpose of this step is to alert all participants of the pending planning requirements; determine the amount of time available for planning and preparation and decide on a planning approach, including guidance on how to design and abbreviate the MDMP, if required. When a new mission is identified, commanders and staffs perform the actions and produce the outputs as described in the following paragraphs.

1. Alert the staff and other key participants.
2. Gather the tools. Once notified of the new planning requirement, the staff prepares for mission analysis by gathering the tools needed to perform it. These tools include, but are not limited to:
  - Appropriate manuals, including ADRP 5-0, *The Operations Process*, and ADRP 1-02, *Terms and Military Symbols*.
  - All documents related to the mission and the area of operations, including the higher headquarters' operation plan and operation order, maps and terrain products, and operational graphics.
  - Higher headquarters' and other organizations' intelligence and assessment products.
  - Estimates and products of other military and civilian organizations.
  - Both the unit's own and the higher headquarters' standing operating procedures.
  - Updated running estimates.
  - Army design methodology products.

3. Update running estimates.

4. Conduct an initial assessment. During receipt of mission, the commander and staff conduct an initial assessment of time and resources available to plan, prepare, and begin execution of an operation. This initial assessment helps the commander determine the following:

- Time needed to plan and prepare for the mission.
- Guidance on using the Army design methodology and abbreviating the MDMP, if required.
- Which outside agencies and organizations to contact and incorporate into the planning process.
- The staff's experience, cohesiveness, and level of rest or stress.

The chief of staff or executive officer develops a staff planning timeline that outlines how long the headquarters can spend on each step of the MDMP. The staff planning timeline indicates what products are due, who is responsible for them, and who receives them.

5. Issue the commander's initial guidance. Initial guidance includes the following:

- Initial time allocations.
- Decision to initiate design or go directly into the MDMP.
- How to abbreviate the MDMP, if required.
- Necessary coordination to perform, including liaison officers to exchange.
- Authorized movements to begin information collection activities.
- Collaborative planning times and locations.
- Initial information requirements.
- Additional staff tasks.

6. Issue a warning order (WARNORD #1). The WARNORD includes, at a minimum, the type of operation, the general location of the operation, the initial timeline, and any movement or reconnaissance to initiate.

## Chapter 4

# Mission Analysis

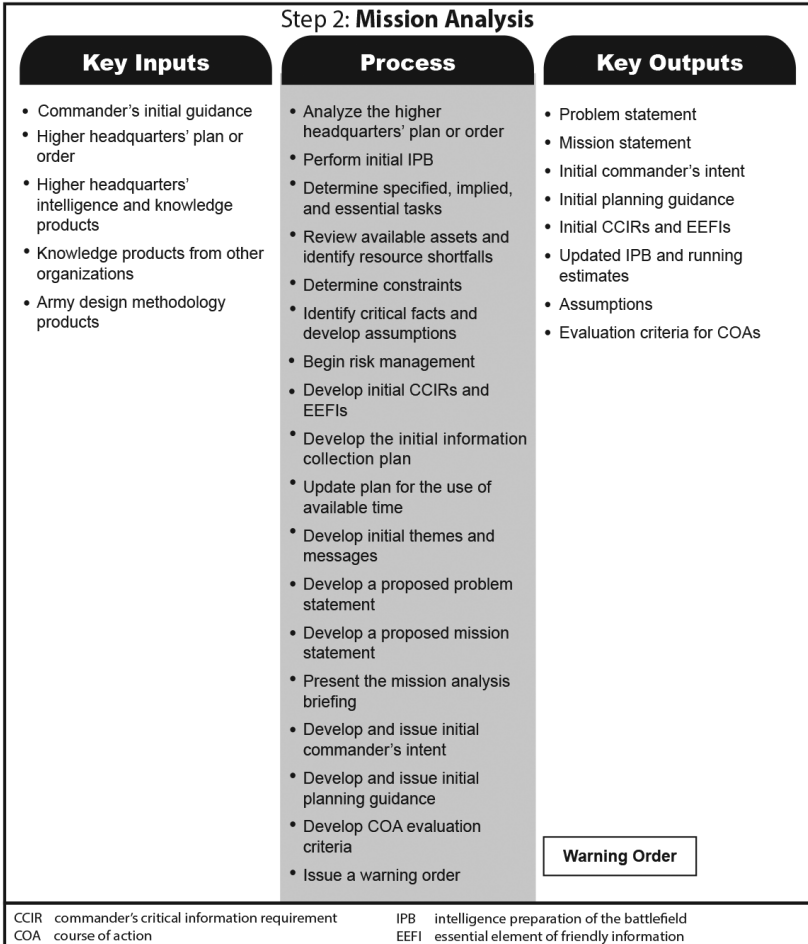

**Figure 4-1. Mission analysis overview (FM 6-0)**

If the MDMP is, simply speaking, a systematic method to solve a specific problem, then mission analysis is the method to clearly identify the problem and the tools available to solve the problem.

During the mission analysis step, the staff analyzes the higher headquarters' plans or orders to ensure staff members fully understand the mission, intent, resources available, constraints and limitations, and specified and implied tasks. The staff performs initial intelligence preparation of the battlefield (IPB); develops critical facts and assumptions; and determines the initial commander's critical information requirements (CCIRs) and essential elements of friendly information (EEFIs). At the end of this step, the staff has developed a proposed problem statement and a proposed mission statement; has presented the mission analysis briefing; is prepared to develop courses of action; and issues a warning order to subordinate units.

While the staff is conducting its analysis, the commander is conducting his own. The commander's analysis provides a frame of reference that helps to quickly assess the staff's work. Though mission analysis marks the beginning of the staff estimate, it is not a one-time effort. Mission analysis is a continuous effort that is constantly re-evaluated as the situation develops and new information is presented.

### **Mission Analysis Steps**

- Step 1: Analyze the higher headquarters' plan or order.
- Step 2: Perform initial IPB.
- Step 3: Determine specified, implied, and essential tasks.
- Step 4: Review available assets and identify resource shortfalls.
- Step 5: Determine constraints.
- Step 6: Identify critical facts and develop assumptions.
- Step 7: Begin risk management.
- Step 8: Determine initial CCIRs and EEFIs.
- Step 9: Develop initial information collection plan.
- Step 10: Update plan for the use of available time.
- Step 11: Develop initial themes and messages.
- Step 12: Develop a proposed problem statement.
- Step 13: Develop a proposed mission statement.
- Step 14: Present the mission analysis briefing.
- Step 15: Develop and issue the initial commander's intent.
- Step 16: Develop and issue initial planning guidance.
- Step 17: Develop course of action (COA) evaluation criteria.
- Step 18: Issue a warning order (WARNORD).

## **Step 1: Analyze the higher headquarters' plan or order.**

Commanders and staffs thoroughly analyze the higher headquarters' plan or order to determine how their unit — by task and purpose — contributes to the mission, commander's intent, and concept of operations of the higher headquarters. The commander and staff seek complete understanding of the following:

- Higher headquarters:
  - Commander's intent.
  - Mission.
  - Concept of operations.
  - Available assets.
  - Timeline.
- Missions of adjacent, supporting, and supported units and their relationship to the higher headquarters' plan.
- Missions of interagency (IO), intergovernmental (IGO), and nongovernmental (NGO) organizations that work in their operational areas.
- Their assigned area of operations (AO).

Liaison officers familiar with the higher headquarters' plan can help clarify issues. Collaborative planning with the higher headquarters also facilitates this task. Staffs also use requests for information (RFIs) to clarify or obtain additional information from the higher headquarters.

## **Step 2: Perform Initial Intelligence Preparation of the Battlefield (IPB).**

IPB is the systematic process of analyzing the mission variables of enemy, terrain, weather, and civil considerations in an area of interest to determine their effect on operations. The IPB process identifies critical gaps in the commander's knowledge of an operational environment. As a part of the initial planning guidance, commanders use these gaps as a guide to establish their initial intelligence requirements. IPB products enable the commander to assess facts about the operational environment and make assumptions about how friendly and threat forces will interact in the operational environment. The description of the operational environment's effects identifies constraints on potential friendly COAs. It also identifies key aspects of the operational environment, such as avenues of approach, engagement areas, and landing zones, which the staff integrates into potential friendly COAs and running estimates. For mission analysis, the intelligence staff, along with the other staff elements, will use IPB to develop detailed threat COA models, which depict a COA available to the

threat. The threat COA models provide a basis for formulating friendly COAs and completing the intelligence estimate.

The intelligence staff, in collaboration with other staff sections, develops other IPB products during mission analysis. That collaboration should result in the drafting of initial priority intelligence requirements (PIRs), the production of a complete modified combined obstacles overlay, a list of high-value targets, and unrefined event templates and matrices. IPB should provide an understanding of the threat's center of gravity, which then can be exploited by friendly forces.

**(Note:** The IPB is arguably the most important portion of the MDMP. It identifies where you are operating and who is operating with and against you. The rest of the MDMP builds upon this fundamental framework.) For detailed information on the IPB process, refer to ATP 2-01.3, *Intelligence Preparation of the Battlefield/Battlespace*.

### **Step 3: Determine specified, implied, and essential tasks.**

The staff analyzes the higher headquarters' order and the higher commander's guidance to determine its specified and implied tasks.

In the context of operations, a task is a clearly defined and measurable activity accomplished by Soldiers, units, and organizations that may support or that other tasks support. The "what" of a mission statement is always a task.

Specified tasks are tasks specifically assigned to a unit by its higher headquarters. The higher headquarters may assign the tasks either orally during collaborative planning sessions or in directives from the higher commander.

Implied tasks are tasks the unit must perform to accomplish a specified task or the mission, but the higher headquarters' order does not state them. The staff derives implied tasks from a detailed analysis of the higher headquarters' order, the enemy situation, the terrain, and civil considerations. Additionally, analysis of doctrinal requirements for each specified task might disclose implied tasks. Units with an assigned AO are responsible for ensuring the conduct of essential stability tasks for the population in areas they control. While higher headquarters specifies some stability tasks, commanders consider the primary stability tasks found in FM 3-07, *Stability Operations*, as sources for implied tasks. These implied tasks, at a minimum, provide for civil security, restoration of essential services, and civil control for civil populations in the AO they control. Based on this analysis, the staff determines if there are other agencies, civil or military, that can provide these tasks. If not, the unit plans to provide these tasks using available assets. If the unit determines it does not have the assets, it informs its higher headquarters.

Once staff members have identified specified and implied tasks, they ensure they understand each task's requirements and the purpose for accomplishing each task. They then determine the task or tasks units must successfully execute to accomplish the mission.

Essential tasks are specified or implied tasks the unit must execute to accomplish the mission. Essential tasks are always included in the unit's mission statement.

#### **Step 4: Review available assets; identify resource shortfalls.**

The commander and staff examine additions to and deletions from the current task organization, command and support relationships, and status (current capabilities and limitations) of all units. This analysis also includes the capabilities of civilian and military organizations (joint, special operations, host nation, and multinational) that operate within the unit's AO. The commander and staff consider relationships between and among specified, implied, and essential tasks and available assets. From this analysis, staffs determine if they have the assets needed to accomplish all tasks. If shortages occur, they identify additional resources needed for mission success to the higher headquarters. Staffs also identify any deviations from the normal task organization. A more detailed analysis of available assets occurs during COA development.

#### **Step 5: Determine constraints.**

The commander and staff identify any constraints placed on their command. A constraint is a restriction placed on the command by a higher headquarters. A constraint dictates an action or inaction, thus restricting the freedom of action of a subordinate commander. Commanders find constraints in paragraph 3 in the operation plan (OPLAN) or operation order (OPORD). Annexes to the order may also include constraints. The operations overlay, for example, may contain a restrictive fire line or a no-fire area. Commanders may issue constraints orally, in WARNORDs, or in policy memorandums.

#### **Step 6: Identify critical facts and develop assumptions.**

Imperfect knowledge and assumptions about the future form the basis for all planning.

A fact is a statement of truth or a statement considered to be true at the time. Facts concerning the operational and mission variables serve as the basis for developing situational understanding, for continued planning, and for assessing progress during preparation and execution.

An assumption is a supposition on the current situation or a presupposition on the future course of events, either or both assumed to be true in the absence of positive proof, necessary to enable the commander in the process of planning to complete an estimate of the situation and make a decision on the COA.

Appropriate assumptions used during planning have two characteristics:

- They are likely to be true.
- They are necessary — that is, essential — to continue planning.

Key points concerning the use of assumptions:

- Assumptions must be logical, realistic, and considered likely to be true.
- Too many assumptions result in a higher probability the plan or proposed solution may be invalid.
- The use of assumptions requires the staff to develop branches and sequels to execute if one or more key assumptions prove false.
- Often, an unstated assumption may prove more dangerous than a stated assumption proven wrong.

Replace assumptions with facts as soon as possible. The staff identifies information needed to convert assumptions into facts and submits them to the appropriate agency as information requirements. If the commander needs information to make a decision, he may designate the information requirement as one of his CCIRs. Submit requirements for information about threats and the environment to the S-2, who incorporates them into the initial information collection plan.

**Note:** Assumptions induce risk into operational planning. Consider these assumptions during risk management.

### **Step 7: Begin risk management.**

Risk management is the Army's process of identifying, assessing, and controlling risks arising from operational factors and making decisions that balance risk cost with mission benefits. During mission analysis, the commander and staff focus on identifying and assessing hazards. Developing specific control measures to mitigate those hazards occurs during course of action development.

The chief of protection (or operations staff officer (S-3) in units without a protection cell) in coordination with the safety officer integrates risk management into the MDMP. All staff sections integrate risk management for hazards within their functional areas. Units conduct the first four steps of risk management in the MDMP. ATP 5-19, *Risk Management*, addresses the details for conducting risk management, including products of each step.



Military Decision-making Process	Risk Management Steps				
	Step 1 Identify Hazards	Step 2 Assess Hazards	Step 3 Develop Controls (+) Decision	Step 4 Implement Controls	Step 5 Supervise (+) Evaluate
Mission Receipt	X				
Mission Analysis	X	X			
COA Development	X	X	X		
COA Analysis	X	X	X		
COA Comparison			X		
COA Approval			X		
Orders Production			X	X	
Rehearsal	X	X	X	X	X
Execution/Assessment	X	X	X	X	X

Figure 4-2. Risk management in MDMP (ATP 5-19)

### Step 8: Develop initial CCIRs and EEFI.

Mission analysis identifies gaps in information required for further planning and decision making during preparation and execution. During mission analysis, the staff develops information requirements.

Information requirements are all information elements the commander and staff require for the successful conduct of operations; that is, all elements necessary to address the factors of METT-TC (mission, enemy, terrain and weather, troops and support available — time available and civil considerations). Some information requirements are of such importance to the commander that the staff nominates them to the commander to become a CCIR. The two types of CCIRs are priority information requirements (PIRs) and friendly force information requirements (FFIRs).

- PIRs: Those intelligence requirements stated as a priority for intelligence support that the commander and staff need in order to understand the adversary or the operational environment (OE).
- FFIRs: Information the commander and staff need in order to understand the status of friendly force and supporting capabilities.

The initial CCIRs developed during mission analysis normally focus on decisions the commander must make to focus planning. Once the commander selects a COA, the CCIRs shift to information the commander needs in order to make decisions during preparation and execution.

Essential Elements of Friendly Information (EEFIs) establish an element of information to protect rather than one to collect. EEFIs identify those elements of friendly force information that, if compromised, would jeopardize mission success.

Depending on the situation, the commander and selected staff meet prior to the mission analysis briefing to approve the initial CCIRs and EEFIs. This

is especially important if the commander intends to conduct intelligence collection operations early in the planning process. The approval of the initial CCIRs, early in planning, assists the staff in developing the initial and subsequent intelligence collection plans. Approval of EEFIs allows the staff to begin planning and implementing measures to protect friendly force information, such as deception and operations security.

### **Step 9: Develop the initial information collection plan.**

The initial information collection plan is crucial to begin or adjust the information collection effort, which helps answer information requirements necessary in developing effective plans. The initial information collection plan sets intelligence, surveillance, and reconnaissance operations in motion. It may be issued as part of a WARNORD, a fragmentary order (FRAGORD), or an OPORD. As more information becomes available, it is incorporated into a complete information collection plan (Annex L) to the OPORD.

The intelligence staff creates the requirements-management tools for the information collection plan. The operations staff is responsible for the information collection plan. During this step, the operations and intelligence staff work closely to ensure they fully synchronize and integrate information collection activities into the overall plan.

The operations officer considers several factors when developing the initial information collection plan, including:

- Requirements for collection assets in subsequent missions.
- Time available to develop and refine the initial information collection plan.
- The risk the commander is willing to accept if information collection missions are begun before the information collection plan is fully integrated into the scheme of maneuver.
- Insertion and extraction methods for reconnaissance, security, surveillance, and intelligence collection assets.
- Contingencies for inclement weather to ensure coverage of key named areas of interest or target areas of interest.
- The communications plan for transmission of reports from assets to command posts.
- The inclusion of collection asset locations and movements into the fire support plan.
- The reconnaissance handover with higher or subordinate echelons.
- The sustainment support.
- Legal support requirements.

FM 3-55, *Information Collection*, contains additional information on information collection, planning requirements, and assessing collection.

### **Step 10: Update plan for the use of available time.**

The commander and staff compare the time needed to accomplish tasks to the higher headquarters' timeline to ensure mission accomplishment is possible in the allotted time. They also compare the timeline to the assumed enemy timeline or the projected timelines within the civil sector regarding the anticipation of how conditions may unfold. From this, they determine windows of opportunity for exploitation, times when the unit will be at risk for enemy activity, or when action to arrest (stop) deterioration in the civil sector is required.

The commander and executive officer (XO) also refine the staff planning timeline:

- Subject, time, and location of briefings the commander requires.
- Times of collaborative planning sessions and the medium over which they will take place.
- Times, locations, and forms of rehearsals.

### **Step 11: Develop initial themes and messages.**

Gaining and maintaining the trust of key actors are an important aspect of operations. Faced with the many different actors (individuals, organizations, and the public) connected with the operation, commanders identify and engage those actors who matter to operational success. These actors' behaviors can help solve or complicate the friendly forces' challenges as commanders strive to accomplish missions.

Themes and messages support operations and military actions. Commanders and their units coordinate what they do, say, and portray through themes and messages. A theme is a unifying or dominant idea or image that expresses the purpose for military action. Themes tie to objectives, lines of effort, and end-state conditions. They are overarching and apply to capabilities of public affairs, military information support operations, and Soldier and leader engagements. A message is an oral, written, or electronic communication that supports a theme focused on a specific actor or the public and in support of a specific action (task). Units transmit themes and messages to those actors or the public whose perceptions, attitudes, beliefs, and behaviors matter to the success of an operation.

The public affairs officer adjusts and refines themes and messages received from higher headquarters for use by the command. These themes and messages are designed to inform specific domestic and foreign audiences about current or planned military operations. The military information support operations element receives approved themes and messages. This element adjusts or refines depending on the situation. It employs themes and messages as part of planned activities designed to influence specific foreign audiences for various purposes that support current or planned operations.

The commander and the chief of staff approve all themes and messages used to support operations. The information operations officer assists the S-3 and the commander to deconflict and synchronize the use of information-related capabilities used specifically to disseminate approved themes and messages during operations.

**Note:** To ensure a common “narrative,” develop, synchronize, and execute all themes and messages across all inform-and-influence activities.

“Inform-and-influence activities” is defined as the integrating activities within the mission command warfighting function which ensure that themes and messages designed to inform domestic audiences and influence foreign friendly, neutral, adversary, and enemy populations are synchronized with actions to support full spectrum operations. Inform-and-influence activities incorporate components and enablers, expanding the commander’s ability to use other resources to inform and influence.

### **Step 12: Develop a proposed problem statement.**

A problem is an issue or obstacle that makes it difficult to achieve a desired goal or objective. The problem statement is the description of the primary issue or issues that may impede commanders from achieving their desired end states.

**Note:** The commander, staff, and other partners develop the problem statement as part of Army design methodology. During mission analysis, the commander and staff review the problem statement and revise it as necessary based on the increased understanding of the situation. If Army design methodology activities do not precede mission analysis, then the commander and staff develop a problem statement prior to moving to Step 3 of the MDMP, COA Development.

How the problem is formulated leads to particular solutions. It is important that commanders dedicate the time to identify the right problem to solve and describe it clearly in a problem statement. Ideally, the commander and staff meet to share their analysis of the situation. They talk with each other, synthesize the results of the current mission analysis, and determine the problem.

As part of the discussion to help identify and understand the problem, the staff compares the current situation to the desired end state, and brainstorms and lists issues that impeded the commander from achieving the desired end state.

Based on this analysis, the staff develops a proposed problem statement — a statement of the problem or set of problems to be solved — for the commander’s approval.

### **Step 13: Develop a proposed mission statement.**

The chief of staff, executive officer, or operations officer prepares a proposed mission statement based on mission analysis and presents it for approval normally during the mission analysis briefing.

The mission statement is a short sentence or paragraph that describes the organization's essential task(s) and purpose — a clear statement of the action to be taken and the reason for doing so. The mission statement contains the elements of who, what, when, where, and why, but seldom specifies how.

The five elements of a mission statement answer the following questions:

- Who will execute the operation (unit/organization)?
- What is the unit's essential task (tactical mission task)?
- When will the operation begin (time/event) or what is the duration?
- Where will the operation occur (AO, objective, and grid coordinates)?
- Why will the force conduct the operation (for what purpose or reason)?

The unit mission statement, along with the commander's intent, provides the primary focus for subordinate actions during planning, preparation, execution, and assessment. The who, where, and when of a mission statement are straightforward.

The what and why are more challenging to write and can confuse subordinates if not stated clearly. What is a task? Express it in terms of action verbs.

The why puts the task into context by describing the reason for performing it. The why provides the mission's purpose — the reason the unit is to perform the task. It is extremely important to mission command and mission orders. Examples of three mission statements are shown on the next page.

**Example 1:** Not later than (NLT) 220400 Aug 09 (when), 1st Brigade (who) secures ROUTE SOUTH DAKOTA (what/task) in AO JACKRABBIT (where) to enable the movement of humanitarian assistance materials (why/purpose).

**Example 2:** 1-505th Parachute Infantry Regiment (who) seizes (what/task) AIRPORT (where) not later than D-day, H+3 (when) to allow follow-on forces to air-land into AO SPARTAN (why/ purpose).

**Example 3:** The 1-509th Parachute Infantry Regiment (who) seizes (what/task) AIRPORT (where) not later than D-day, H+3 (when) to allow follow-on forces to air-land into AO SPARTAN (why/purpose). On order (when), secure (what/task) OBJECTIVE GOLD (where) to prevent the 2d Pandor Guards Brigade from crossing the BLUE RIVER and disrupting operations in AO SPARTAN (why/purpose).

## **Step 14: Present the mission analysis briefing.**

The mission analysis briefing informs the commander of the results of the staff's analysis of the situation. It helps the commander understand, visualize, and describe the operation. Throughout the mission analysis briefing, the commander, staff, and other partners discuss the various facts and assumptions about the situation. Staff officers present a summary of their running estimates from their specific functional area and how their findings impact or are impacted by other areas. This helps the commander and staff as a whole to focus on the interrelationships among the mission variables and to develop a deeper understanding of the situation. The commander issues guidance to the staff for continued planning based on situational understanding gained from the mission analysis briefing.

Ideally, the commander holds several informal meetings with key staff members before the mission analysis briefing, including meetings to assist the commander in developing CCIRs, the mission statement, and themes and messages. These meetings enable commanders to issue guidance for activities (such as reconnaissance, surveillance, security, and intelligence operations) and develop their initial commander's intent and planning guidance.

A comprehensive mission analysis briefing helps the commander, staff, subordinates, and other partners develop a shared understanding of the requirements of the upcoming operation. Time permitting, the staff briefs the commander on its mission analysis using the following outline:

- Mission and commander's intent of the headquarters two echelons up.
- Mission, commander's intent, and concept of operations of the headquarters one echelon up.
- A proposed problem statement.

- A proposed mission statement.
- Review of the commander's initial guidance.
- Initial IPB products, including civil considerations that affect the conduct of operations.
- Specified, implied, and essential tasks.
- Pertinent facts and assumptions.
- Constraints.
- Forces available and resource shortfalls.
- Initial risk assessment.
- Proposed themes and messages.
- Initial information collection plan.
- Recommended timeline.
- Recommended collaborative planning sessions.

During the mission analysis briefing or shortly thereafter, commanders approve the mission statement and CCIRs. They then develop and issue their initial commander's intent and planning guidance.

### **Step 15: Develop and issue the initial commander's intent.**

The commander's intent succinctly describes what constitutes success for the operation. It includes the operation's purpose and the conditions that define the end state. The commander's intent links the mission, concept of operations, and tasks to subordinate units. During planning, the initial commander's intent summarizes the commander's visualization. The commander's intent should be used to develop and refine COAs. During execution, the commander's intent spurs individual initiative.

### **Step 16: Develop and issue the initial planning guidance.**

Commanders provide planning guidance along with their initial intent. Planning guidance conveys the essence of the commander's visualization. Guidance may be broad or detailed. It outlines an operational approach — the broad general actions that will produce the conditions that define the desired end state. The guidance should outline specific COAs the commander wants the staff to look at and rule out any COAs he will not accept.

**(Note:** Refer to ADRP 5-0, *The Operations Process*, for additional information on commander's guidance.)

When developing their concept of operations, commanders first visualize the decisive operation and develop shaping and sustaining operations to support the decisive operation. The decisive operation is the focal point around which commanders develop the entire operation and prioritize effort.

### **Step 17: Develop COA evaluation criteria.**

Evaluation criteria are factors the commander and staff will later use to measure the relative effectiveness and efficiency of one COA relative to other COAs. Developing these criteria during mission analysis or as part of the commander's planning guidance helps to eliminate a source of bias prior to COA analysis and comparison.

Normally, the executive officer initially determines each proposed criterion, with weights based on the assessment of its relative importance and the commander's guidance. Commanders adjust criterion selection and weighting according to their own experience and vision. Sample evaluation criteria:

- Simplicity.
- Maneuver.
- Fires.
- Civil control.
- Support mission narrative.

Other possible criteria: time required, casualties, damage to infrastructure, host-nation special operating forces integration, local support, media impact, and external agency support.

### **Step 18: Issue a WARNORD.**

Immediately after the commander gives the planning guidance, the staff sends subordinate and supporting units a WARNORD (WARNORD #2) that contains, at a minimum, the following information:

- Approved mission statement
- Commander's intent
- Changes to task organization
- Unit AO (sketch, overlay, or some other description)
- CCIRs and EEFI
- Risk guidance
- Priorities by warfighting functions
- Military deception guidance
- Essential stability tasks
- Initial information collection plan
- Specific priorities
- Updated operational timeline
- Movements



## Lessons and Best Practices

**Observation:** CCIRs are often not tied to decisions.

**Discussion:** The exercise of mission command reduces the number of decisions the commander must make. This allows him and the staff to focus on the most important decisions that cannot or will not be delegated. Required decisions drive the development of CCIRs, PIRs, and FFIRs. The staff focuses on the CCIRs to support the commander's decision making and develops a battle rhythm that supports the commander's decision cycle. Failure to clearly define the commander's decisions wastes valuable time, causing the staff to try to assist the commander in understanding problems that are not his to solve. Often, the staff presents or focuses on irrelevant information that exhausts collection assets and analysis efforts by looking at the wrong things.

**Recommendations:**

- As the commander goes through the mission command process, he should identify his key decisions. This process is continuous as the operational environment changes and affects the mission.
- The staff, under the direction of the XO, should develop decisions that are solely for the commander. Part of the staff's work in helping the commander understand the problem is presenting him with its analysis on required decisions.
- Commanders should adopt a process to guide the staff. This process should include specific responsibilities for development, validations, disseminating, monitoring, reporting, and maintenance (i.e., modifying/deleting) of CCIRs.

## Lessons and Best Practices

**Observation:** Executive officers are routinely challenged in synchronizing or leading the MDMP efforts across the staff.

**Discussion:** XOs often do not understand their role in synchronizing staff efforts during planning. They do not conduct a sufficient time analysis, and they do not develop a detailed “plan to plan.” This detracts from the staff’s ability to execute cross-functional collaborative planning. XOs often do not put enough emphasis on developing and enforcing appropriate digital and analog planning SOPs. Staff personnel understand the basics of the MDMP, but the lack of direction results in stovepiped efforts until personnel are directed to compile slides for the respective MDMP briefing. XOs do not allocate enough time to rehearse and make necessary adjustments. The result is a missed opportunity to help the commander understand and visualize the operation and provide the guidance needed to begin the next step. Units typically end up completing a major portion of the mission analysis during COA development.

### **Recommendations:**

- The XO must lead staff planning efforts to ensure the commander can understand and visualize the operation. The XO must develop a “plan to plan” that includes time for staff to conduct both internal and cross-functional planning sessions. The timeline must address each step and sub-step of the MDMP.
- The XO should make recommendations to the commander on what steps to abbreviate. Units should develop a planning SOP that includes an initial timeline and prescribed formats (analog and digital) to reduce time spent building and refining briefings. Selecting a common map and a common format for products is essential to reducing preparation time.

## Chapter 5

### Course of Action Development

Step 3: <b>Course of Action (COA) Development</b>		
Key inputs	Process	Key outputs
<ul style="list-style-type: none"> <li>• Mission statement</li> <li>• Initial commander's intent, planning guidance, CCIRs and EEFI</li> <li>• Updated IPB and running estimates</li> <li>• Assumptions</li> <li>• Evaluation criteria for COAs</li> </ul>	<ul style="list-style-type: none"> <li>• Assess relative combat power</li> <li>• Generate options</li> <li>• Array forces</li> <li>• Develop a broad concept</li> <li>• Assign headquarters</li> <li>• Develop COA statements and sketches</li> <li>• Conduct COA briefing</li> <li>• Select or modify COAs for continued analysis</li> </ul>	<ul style="list-style-type: none"> <li>• COA statements and sketches                             <ul style="list-style-type: none"> <li>- Tentative task organization</li> <li>- Broad concept of operations</li> </ul> </li> <li>• Revised planning guidance</li> <li>• Updated assumptions</li> </ul>
<small>CCIR commander's critical information requirement COA course of action</small>	<small>EEFI essential element of friendly information IPB intelligence preparation of the battlefield</small>	

**Figure 5-1. Course of action (COA) development (FM 6-0)**

A COA is a broad potential solution to an identified problem. The COA development step generates options for follow-on analysis and comparison that satisfy the commander's intent and planning guidance. During COA development, planners use the problem statement, mission statement, commander's intent, planning guidance, and the various knowledge products developed during mission analysis to develop COAs.

Examine each prospective COA for validity using the following screening criteria:

- **Feasible:** The COA can accomplish the mission within the established time, space, and resource limitations.
- **Acceptable:** The COA must balance cost and risk with the advantage gained.
- **Suitable:** The COA can accomplish the mission within the commander's intent and planning guidance.
- **Distinguishable:** Each COA must differ significantly from the others (such as scheme of maneuver, lines of effort, phasing, use of reserve forces, and task organization).

- Complete: A COA must incorporate the following information:
  - How the decisive operation leads to mission accomplishment.
  - How shaping operations create and preserve conditions for success of the decisive operation or effort.
  - How sustaining operations enable shaping and decisive operations or efforts.
  - How to account for offensive, defensive, and stability or civil support tasks.
  - Tasks to be performed and conditions to be achieved.

COA development includes the following eight steps:

- Step 1: Assess relative combat power.
- Step 2: Generate options.
- Step 3: Array forces.
- Step 4: Develop a broad concept.
- Step 5: Assign headquarters.
- Step 6: Develop COA statements and sketches.
- Step 7: Conduct COA briefing.
- Step 8: Select or modify COAs for continued analysis.

### **Step 1: Assess relative combat power.**

According to ADRP 3-0, *Unified Land Operations*, combat power is the total means of destructive, constructive, and information capabilities that a military unit can apply at a given time. It is the effect created by combining the elements of intelligence, movement and maneuver, fires, sustainment, protection, mission command, information, and leadership. The goal is to generate overwhelming combat power to accomplish the mission at minimal cost.

To assess relative combat power, planners initially make a rough estimate of force ratios of maneuver units two levels down. Planners then compare friendly strengths to enemy weaknesses, and vice versa, for each element of combat power. From these comparisons, they may deduce particular vulnerabilities that may be exploited or may need protection. These comparisons provide planners insight into effective force employment.

For stability and civil support operations, staffs often determine relative combat power by comparing available resources to specified or implied stability or civil support tasks. This is known as troop-to-task analysis. This analysis provides insight into what options are available and whether more resources are required. In such operations, the elements of sustainment, movement and maneuver, nonlethal effects, and information may predominate.

Comparing the most significant strengths and weakness of each force in terms of combat power gives planners insight into the following areas:

- Friendly capabilities that pertain to the operation.
- Types of operations possible from both friendly and enemy perspectives.
- How and where the enemy may be vulnerable.
- How and where friendly forces are vulnerable.
- Additional resources that may be required to execute the mission.
- How to allocate existing resources.

Assessing combat power requires assessing both tangible and intangible factors such as morale and levels of training. A relative combat power assessment identifies enemy weaknesses to exploit, identifies friendly weaknesses that require protection, and determines the combat power necessary to conduct essential stability or civil support tasks.

Planners combine the numerical force ratio with the results of their analysis of intangibles to determine the relative combat power of friendly and enemy forces. They determine what types of operations are feasible by comparing the force ratio to the historical minimum planning ratios for the contemplated combat missions and estimating the extent to which intangible factors affect the relative combat power. If, in the staff's judgment, the relative combat power of the force produces the effects of the historical minimum planning ratio for a contemplated mission, that mission is feasible.

## **Step 2: Generate options.**

Based on commander's guidance and initial results of the relative combat power assessment, the staff generates options. A good COA can defeat all feasible enemy COAs while accounting for essential stability tasks. In an unconstrained environment, the goal is to develop several possible COAs. The commander's guidance may limit options depending on time.

Brainstorming is the preferred technique for generating options. It requires time, imagination, and creativity, but it produces the widest range of choices.

**Note:** When possible, brainstorming should include participants from all agencies and organizations that provide a capability to the planning unit.

When generating options, staff members determine the doctrinal requirements for each proposed operation, including doctrinal tasks for subordinate units. In addition, the staff considers the potential capabilities of attachments and other organizations and agencies outside military channels.

The staff starts with the decisive operation identified in the commander's planning guidance. The staff checks that the decisive operation nests within the higher headquarters' concept of operations. The staff clarifies the decisive operation's purpose and considers ways to mass the effects (lethal and nonlethal) of overwhelming combat power to achieve it.

- The decisive operation is the focal point around which commanders develop the entire operation and prioritize effort.
- The main effort is the designated subordinate unit whose mission at a given point in time is most critical to overall mission success.

Next, the staff considers shaping operations. The staff establishes a purpose for each shaping operation tied to creating or preserving a condition for the decisive operation's success. Shaping operations may occur before, concurrently with, or after the decisive operation.

The staff then determines sustaining operations necessary to create and maintain the combat power required for the decisive operation and shaping operations.

After developing the basic operational organization for a given COA, the staff then determines the essential tasks for each decisive, shaping, and sustaining operation.

Once staff members have explored possibilities for each COA, they examine each COA to determine if it satisfies the previously established screening criteria. In doing so, they change, add, or eliminate COAs as appropriate, but must avoid the common pitfall of focusing on the development of one good COA among several throwaway COAs.

**Step 3: Array forces.**

After determining the decisive and shaping operations and their related tasks and purposes, planners determine the relative combat power required to accomplish each task.

Friendly Mission	Position	Friendly: Enemy
Delay		1:6
Defend	Prepared or fortified	1:3
Defend	Hasty	1:2.5
Attack	Prepared or fortified	3:1
Attack	Hasty	2.5:1
Counterattack	Flank	1:1

**Figure 5-2. Historical minimum planning ratios (FM 6-0)**

In counterinsurgency (and stability) operations, planners can develop force requirements by gauging troop density — the ratio of security forces (including host-nation military and police forces as well as foreign counterinsurgents) to inhabitants. Most density recommendations fall within a range of 20 to 25 counterinsurgents for every 1,000 residents in an AO. (See FM 3-24, *Insurgencies and Countering Insurgencies*)

A COA may require a follow-on force to establish civil security, maintain civil control, and restore essential services in a densely populated urban area over an extended period. Planners conduct a troop-to-task analysis to determine the type of units and capabilities required to accomplish these tasks.

Planners initially array friendly forces starting with the decisive operation and continuing with all shaping and sustaining operations. Planners normally array ground forces two levels down. The initial array focuses on generic ground maneuver units without regard to specific type or task organization, and then considers all appropriate intangible factors. During this step, planners do not assign missions to specific units; they only consider which forces are necessary to accomplish the task. In this step, planners also array assets to accomplish essential stability tasks.

If the number of units arrayed exceeds the number available and compensating for the difference is not possible with intangible factors, the staff determines whether the COA is feasible. Commanders should also consider requirements to minimize and relieve civilian suffering. Establishing civil security and providing essential services such as medical care, food and water, and shelter are implied tasks for commanders during any combat operation.

#### **Step 4: Develop a broad concept.**

The broad concept describes how arrayed forces will accomplish the mission within the commander's intent. It concisely expresses the "how" of the commander's visualization and will eventually provide the framework for the concept of operations. The broad concept summarizes the contributions of all warfighting functions. The staff develops a broad concept for each COA, which it expresses in both narrative and graphic forms.

A sound COA is more than the arraying of forces. It should present an overall combined arms idea that will accomplish the mission.

The broad concept includes the following:

- Purpose of the operation.
- Statement of where the commander will accept risk.
- Identification of critical friendly events and transitions between phases (if the operation is phased).
- Designation of the reserve force, including its location and composition.
- Information collection activities.
- Essential stability tasks.
- Identification of maneuver options that may develop during an operation.
- Assignment of subordinate AOs.
- Scheme of fires.
- Themes, messages, and means of delivery.
- Military deception operations.
- Key control measures.
- Designation of the operational framework for this operation: deep-close-security, main and supporting effort, or decisive-shaping-sustaining.
- Designation of the decisive operation, along with its task and purpose, linked to how it supports the higher headquarters' concept.



**Note:** For the purpose of this section, the decisive-shaping-sustaining operational framework is an example. Planners use the same process when analyzing the other two operational frameworks, deep-close-security and main and supporting effort, to develop initial concepts of the operation.

Planners select control measures, including graphics, to control subordinate units during the operation. Good control measures foster freedom of action, decision making, and individual initiative.

Planners may use both lines of operations and lines of effort to build their broad concept. Lines of operations portray the more traditional links among objectives, decisive points, and centers of gravity. A line of effort, however, helps planners link multiple tasks with goals, objectives, and end-state conditions.

Combining lines of operations with lines of effort allows planners to include nonmilitary activities in their broad concept. This combination helps commanders incorporate stability or defense support of civil authorities – tasks that, when accomplished, help set end-state conditions of an operation.

Based on the commander's planning guidance (informed by the Army design methodology concept if this preceded the MDMP), planners develop lines of effort by confirming end-state conditions from the initial commander's intent and planning guidance, determining and describing each line of effort, and identifying objectives (intermediate goals) and determining tasks along each line of effort.

During COA development, lines of effort are general and lack specifics, such as tasks to subordinate units associated with objectives along each line of effort. Units develop and refine lines of effort, including specific tasks to subordinate units, during war-gaming. (See ADRP 5-0 and FM 3-07 for examples of operations depicted along lines of effort.)

### **Step 5: Assign headquarters.**

After determining the broad concept, planners create a task organization by assigning headquarters to groupings of forces. They consider the types of units for assignment to a headquarters and the ability of that headquarters to control those units. Generally, a headquarters controls at least two subordinate maneuver units (but not more than five) for fast-paced offensive or defensive operations. The number and type of units assigned to a headquarters for stability operations will vary based on factors of mission, enemy, terrain and weather, troops and support available-time available and civil considerations. If planners need additional headquarters, they note the shortage and resolve it later.

## **Step 6: Develop COA statements and sketches.**

The operations officer prepares a COA statement and supporting sketch for each COA. The COA statement clearly portrays how the unit will accomplish the mission. The COA statement should be a brief expression of how to conduct the combined arms concept. The sketch provides a picture of the movement and maneuver aspects of the concept, including the positioning of forces.

At a minimum, the COA sketch includes the array of generic forces and control measures, such as the following:

- Unit and subordinate unit boundaries.
- Unit movement formations (but not subordinate unit formations).
- Line of departure or line of contact and phase lines, if used.
- Information collection graphics.
- Ground and air axes of advance.
- Assembly areas, battle positions, strong points, engagement areas, and objectives.
- Obstacle control measures and tactical mission graphics.
- Fire support coordination and airspace coordinating measures.
- Main effort.
- Location of command posts and critical communications nodes.
- Enemy known or templated locations.
- Population concentrations.

Planners can include identifying features (e.g., cities, rivers, and roads) to help orient users. The sketch may be on any medium.

Graphic control measures (GCMs) are graphic directives given by a commander to subordinate commanders to assign responsibilities, coordinate fire and maneuver, and control combat operations. In general, the commander and staff develop GCMs during COA development. They use GCMs to convey and enhance the understanding of the concept of operations, prevent fratricide, and clarify the task and purpose of the main effort.

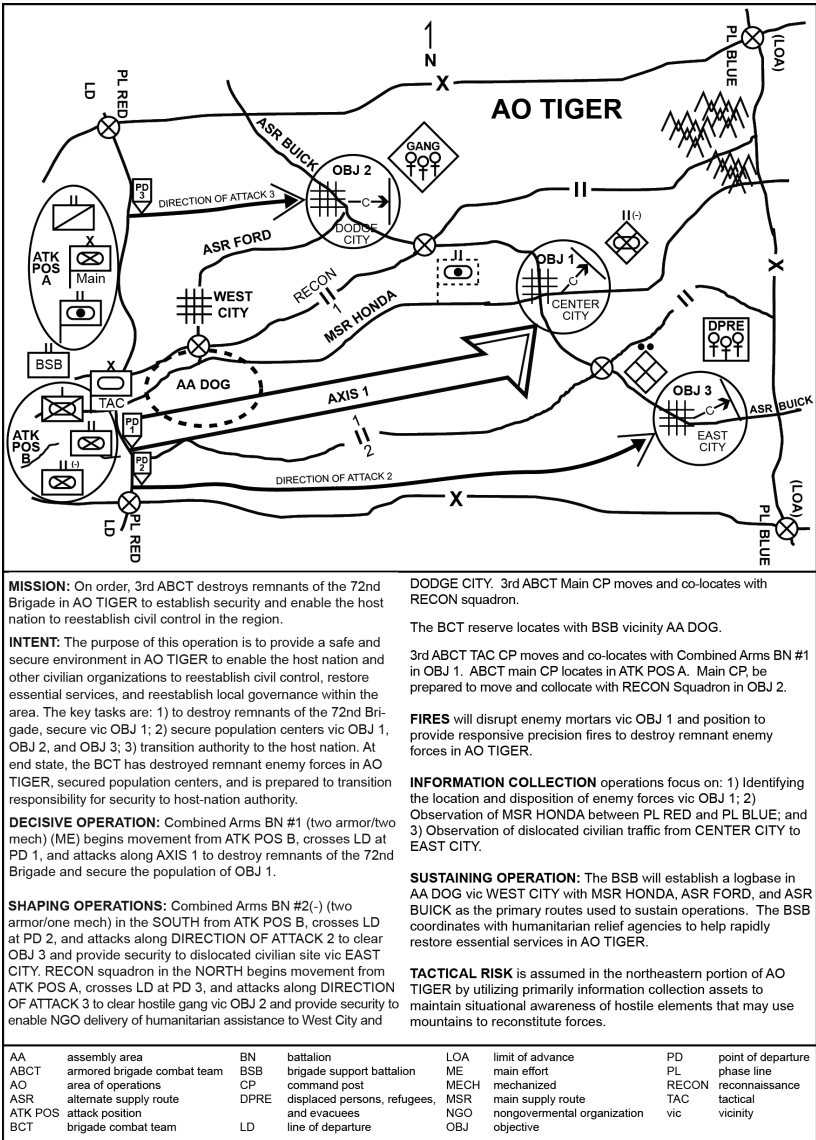

Figure 5-3. Sample brigade COA sketch (FM 6-0)

### **Step 7: Conduct COA briefing.**

After developing COAs, the staff briefs them to the commander. The COA briefing includes the following information:

- Updated IPB (if there are significant changes).
- As many threat COAs as necessary, but at a minimum, most likely and most dangerous COAs must be developed.
- Approved problem statement and mission statement.
- Commander's and higher commander's intents.
- COA statements and sketches, including lines of effort if used.
- The rationale for each COA, including:
  - Considerations that might affect enemy COAs.
  - Critical events for each COA.
  - Deductions resulting from the relative combat power analysis.
  - Reason for unit arrangements as shown on the sketch.
  - Reason the staff used the selected control measures.
  - Impact on civilians.
  - How the COA accounts for minimum essential stability tasks.
  - Updated facts and assumptions.
  - Refined COA evaluation criteria.

### **Step 8: Select or modify COAs for continued analysis.**

After the COA briefing, the commander selects or modifies those COAs for continued analysis. The commander also issues planning guidance. If the commander rejects all COAs, the staff begins again. If one or more of the COAs are accepted, staff members begin COA analysis.

## Lessons and Best Practices

**Observation:** Units deployed to the Combat Training Centers (CTCs) often do not successfully conduct command post (CP) operations to facilitate the commander's mission command of tactical operations.

**Discussion:** Units must practice managing information essential to communicating the common operational picture (COP) and other execution information to achieve situational understanding and to direct the conduct of operations. The staff must establish and revise SOPs to create a set of instructions covering tasks and functions of the command post. Units must also develop their ability to maintain continuity of command through the use of forward CPs (TAC) to ensure the ability of the commander to exercise mission command continuously from any point in the operational environment.

### **Recommendations:**

- Maintain focus through the chaos. The best units rely on their SOPs and can handle the current fight and plan larger operations using MDMP, but also maintain focus on day-to-day progress of targets and lines of effort.
- Organize for flexibility. In operations, effective mission command requires continuous, and often immediate, close coordination, synchronization, and information sharing across staff sections.

## Lessons and Best Practices

**Observation:** Units do not routinely incorporate effective graphic and direct fire control measures to regulate aspects of operations or efficiently control fires to destroy the enemy.

**Discussion:** Units must practice effective use of graphic control measures and direct fire control measures to apply the science of control to their operations. Units must develop COA sketches and graphics that depict unit and subordinate boundaries, the line of departure and phase lines, reconnaissance and security graphics, ground and air axes of advance, assembly areas, battle positions, strongpoints, engagement areas, and objectives. Units must also develop direct fire control measures to control their scheme of maneuver at the templated line of contact, to include fire support control measures, target reference points, and restricted fire lines to better portray how their combined arms concept will be conducted and successfully accomplished. Units also must incorporate these control measures and graphics into rehearsals.

### **Recommendations:**

- Graphic control measures must be used to regulate maneuver, movement, use of airspace, fires, and other aspects of operations.
- All graphic control measures should relate to easily identifiable natural or man-made terrain features.

## Chapter 6

### Course of Action Analysis

Course of action analysis enables commanders and staffs to identify difficulties or coordination problems as well as probable consequences of planned actions for each COA being considered. COA analysis not only assesses the quality of each COA, it also identifies potential execution problems, decisions that must be made, and requirements for contingency planning. COA analysis (war-gaming) is a disciplined process, with rules and steps that attempt to visualize the flow of the operation given the force's strengths and dispositions, the enemy's capabilities and possible COAs, the impact and requirements of civilians in the AO, and other aspects of the situation. The eight steps of COA analysis are:

- Step 1: Gather the tools.
- Step 2: List all friendly forces.
- Step 3: List assumptions.
- Step 4: List known critical events and decision points.
- Step 5: Select the war-gaming method.
- Step 6: Select a technique to record and display results.
- Step 7: War-game the operation and assess results.
- Step 8: Conduct a war-game briefing (optional).

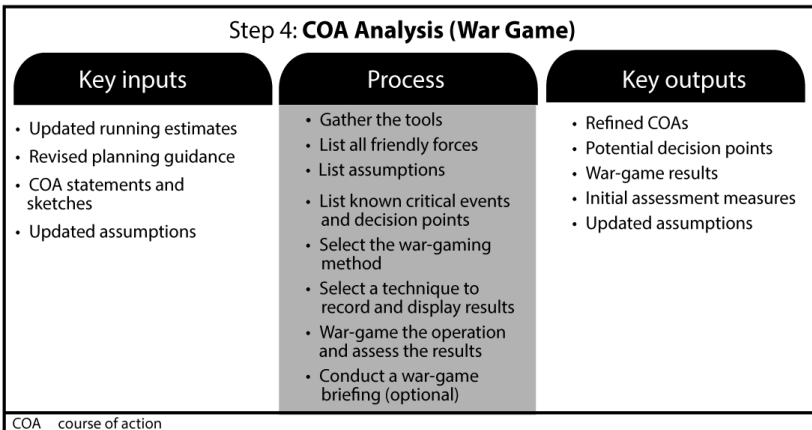

Figure 6-1. COA analysis (FM 6-0)

Each critical event within a proposed COA should be war-gamed using the action, reaction, and counteraction methods of friendly and enemy forces interaction (as well as impact on the local population). This helps the commander and staff to synchronize warfighting functions and:

- Determine how to maximize the effects of combat power while protecting friendly forces and minimizing collateral damage.
- Develop a further visualization of the operation.
- Anticipate operational events.
- Determine conditions and resources required for success.
- Determine when and where to apply force capabilities.
- Identify coordination needed to produce synchronized results.
- Determine the most flexible COA.

The staff's war-gaming results in refined COAs, a completed synchronization matrix, and decision support templates and matrices for each COA. War gamers need to:

- Remain objective, not allowing personality or their sense of what the commander wants to influence them. (They avoid defending a COA just because they personally developed it.)
- Record advantages and disadvantages of each COA accurately as they emerge.
- Continually assess feasibility, acceptability, and suitability of each COA. (If a COA fails any of these tests, they reject it.)
- Avoid drawing premature conclusions and gathering facts to support such conclusions.
- Avoid comparing one COA with another during the war game. (This occurs during COA comparison.)



## War-gaming Steps

### Step 1: Gather the tools.

The executive officer directs the staff to gather tools, materials, and data for the war game. Units war-game with maps, sand tables, computer simulations, or other tools that accurately reflect the physical and human terrain. The staff posts the COA on a map displaying the AO. Tools required include but are not limited to the following:

- Running estimates.
- Threat templates and models.
- Civil considerations overlays, databases, and data files.
- Modified combined obstacle overlays and terrain effects matrices.
- Recording method.
- Completed COAs, including graphics.
- Means to post or display enemy and friendly unit symbols and other organizations.
- Map of the AO.

### Step 2: List all friendly forces.

The commander and staff consider all units that can be committed to the operation, paying special attention to support relationships and constraints. This list must include assets from all participants operating in the AO. The friendly forces list remains constant for all COAs. The staff should take into account elements such as host-nation special operations forces and nongovernmental and interagency organizations.

### Step 3: List assumptions.

The commander and staff review previous assumptions for continued validity and necessity.

#### **Step 4: List known critical events and decision points.**

Critical events are those that directly influence mission accomplishment. They include events that trigger significant actions or decisions (such as commitment of an enemy reserve), complicated actions requiring detailed study (such as a passage of lines), and essential tasks. The list of critical events includes major events from the unit's current position through mission accomplishment. It includes reactions by civilians that might affect operations or that will require allocation of significant assets to account for essential stability tasks.

A decision point is a point in space and time when the commander or staff anticipates making a key decision concerning a specific COA (JP 5-0, Joint Operation Planning). Decision points may also be associated with the friendly force and the status of ongoing operations. A decision point may be associated with the commander's critical information requirements (CCIRs), which describe what information the commander needs in order to make the anticipated decision. The priority information requirement (PIR) describes what the commander must know about the enemy or the operational environment and often is associated with a named area of interest (NAI).

#### **Step 5: Select the war-gaming method.**

There are three recommended war-gaming methods: belt, avenue in depth, and box. Each considers the area of interest and all enemy forces that can affect the outcome of the operation. The staff can use these methods separately or in combination for long-term operations dominated by stability.

**The belt method** divides the AO into areas running the width of the AO based on the METT-TC factors of mission, enemy, terrain and weather, troops and support available-time available and civil considerations. The belt method is most effective when the terrain is divided into well-defined cross-compartments, during phased operations, or when the enemy deploys in clearly defined belts or echelons. Belts can be adjacent to or overlap each other. The basis for this war-gaming method is a sequential analysis of events in each belt. It is preferred because it focuses simultaneously on all forces affecting a particular event. The modified belt method divides the AO into not more than three sequential belts. In stability operations, the belt method can divide the COA by events, objectives (goals, not geographic location), or events and objectives in a selected slice across all lines of effort.

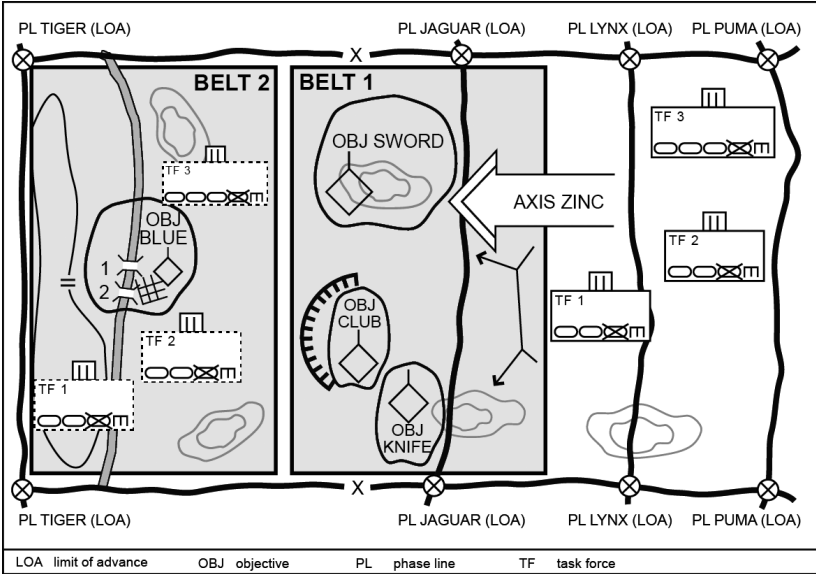

Figure 6-2. Sample belt method (FM 6-0)

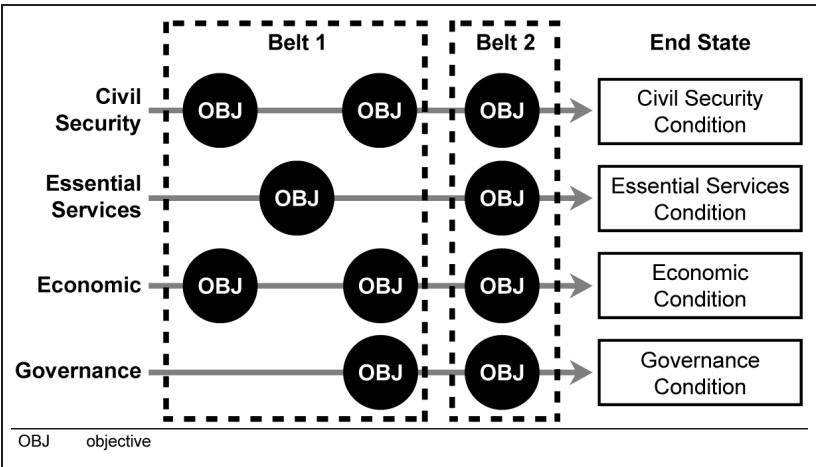

Figure 6-3. Sample belt method using lines of effort (FM 6-0)

**The avenue-in-depth method** focuses on one avenue of approach at a time, beginning with the decisive operation. This method is good for offensive COAs or in the defense when canalizing terrain inhibits mutual support. In stability operations, the staff may modify the avenue-in-depth method. Instead of focusing on a geographic avenue, the staff war-games a line of effort. This method focuses on one line of effort at a time, beginning with the decisive line. It includes not only the war-gaming events, or objectives in the selected line, but also war-gaming relationships among events or objectives on all lines of effort with respect to events in the selected line.

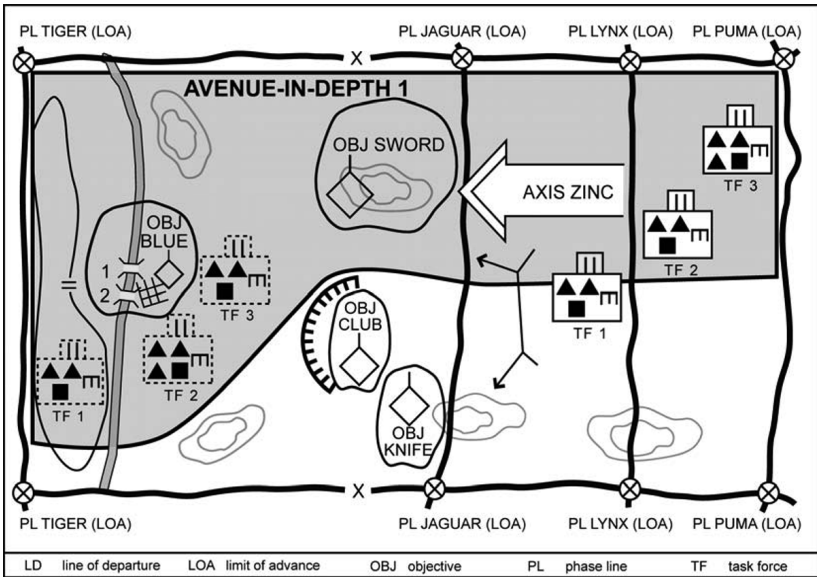

Figure 6-4. Sample avenue-in-depth method (FM 6-0)

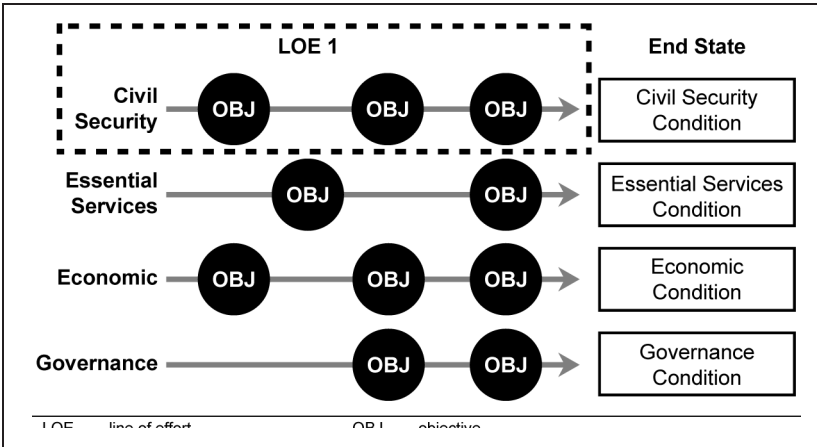

Figure 6-5. Sample avenue-in-depth method for stability operations (FM 6-0)

**The box method** is a detailed analysis of a critical area, such as an engagement area, a river crossing site, or a landing zone. It works best in a time-constrained environment, such as a hasty attack. It is particularly useful when planning operations in noncontiguous AOs. The staff isolates the area and focuses on critical events in it. Staff members assume that friendly units can handle most situations in the AOs and focus their attention on essential tasks. In stability operations, the box method may focus analysis on a specific objective along a line of effort such as development of local security forces as part of improving civil security. (See Figures 6-6 and 6-7 on the next page.)

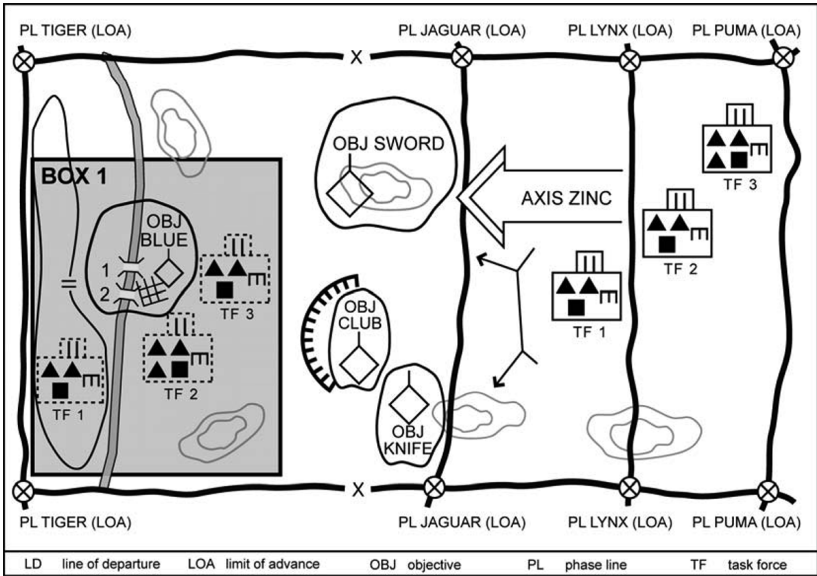

Figure 6-6. Sample box method (FM 6-0)

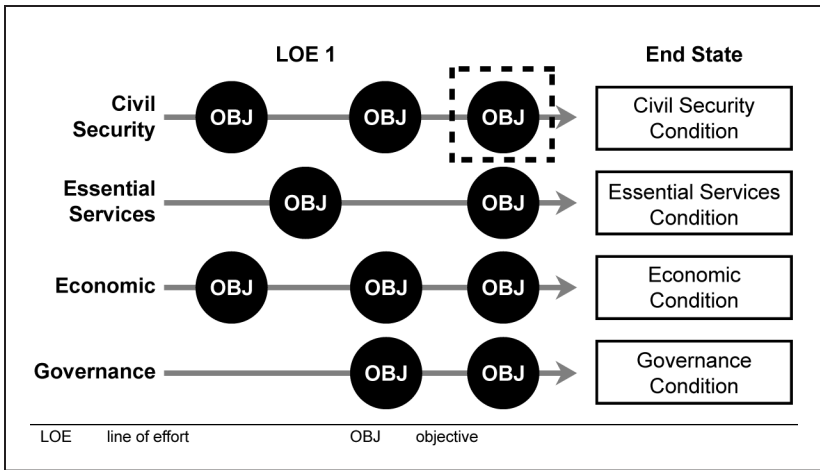

Figure 6-7. Sample box method for stability operations (FM 6-0)

**Step 6: Select a technique to record and display results.**

The results of the war game provide a record from which to build task organizations, synchronize activities, develop decision support templates, confirm and refine event templates, prepare plans or orders, and compare COAs. Two techniques are commonly used to record and display results: the synchronization matrix technique and the sketch note technique. In both techniques, staff members record any remarks regarding the strengths and weaknesses they discover.

The synchronization matrix is generally the most common technique. The synchronization matrix is a tool the staff uses to record the results of war gaming and helps it synchronize a COA across time, space, and purpose in relationship to potential enemy and civil actions.

Time/Event/Phase		H - 24 hours (or event or phase)	H-hour (or event or phase)	H + 24 (or event or phase)
Enemy Action		Initiates threat activities and movements	Defends from security zone	Commits reserve
Population or Civilian Action		Orderly evacuation from area continues		
Decision Points		Conduct aviation attack of OBJ Irene		
Control Measures				
Movement and Manuever	1 <sup>st</sup> ABCT	Move on Route Irish	Cross LD	Seize on OBJ Irene
	2 <sup>d</sup> ABCT	Move on Route Longstreet	Cross LD	Seize on OBJ Rose
	3 <sup>d</sup> ABCT			FPOL with 1 <sup>st</sup> BCT
	AVN Bde	Attack enemy reserve on OBJ Irene		
	BFSB			
Reserve				
Information Collection				
Fires		Prep fires initiated at H-5 Suppression of enemy air defense initiated		
Protection	Engineer			
	PMO			
	CBRN			
Sustainment				
Mission Command			Main CP with 1 <sup>st</sup> BCT	
Close Air Support				
Electronic Warfare			Enemy command and control jammed	
Nonlethal Effects		Surrender broadcasts and leaflets		
Host Nation				
Interagency				
NGOs			Begins refugee relief	
<b>Note:</b> The first column is representative only and can be modified to fit formation needs.				

**Figure 6-8. Sample synchronization matrix (FM 6-0)**

The sketch note method uses brief notes concerning critical locations or tasks and purposes. These notes refer to specific locations or relate to general considerations covering broad areas.

The commander and staff mark locations on the map and on a separate war game work sheet. Staff members use sequential numbers to link the notes to the corresponding locations on the map or overlay. Staff members also identify actions by placing them in sequential action groups, giving each sub-task a separate number. They use the war game work sheet to identify all pertinent data for a critical event. They assign each event a number and title and use the columns on the work sheet to identify and list in sequence:

- Units and assigned tasks.
- Expected enemy actions and reactions.
- Friendly counteractions and assets.
- Total assets needed for the task.
- Estimated time to accomplish the task.
- The decision point tied to executing the task.
- CCIRs.
- Control measures.
- Remarks.

Critical Event	Seize OBJ Sword		
Sequence number	1		
Action	TF 3 attacks to destroy enemy company on OBJ Sword		
Reaction	Enemy company on OBJ Club counterattacks		
Counteraction	TF 1 suppresses enemy company on OBJ Club		
Assets	TF 3, TF 1, and TF 2		
Time	H+1 to H+4		
Decision Point	DP 3a and 3b		
Commander's critical information requirements	Location of enemy armor reserve west of PL Jaguar		
Control measures	Axis Zinc and support by fire position 1		
Remarks	none		
DP	decision point	PL	phase line
OBJ	objective	TF	task force

**Figure 6-9. Sample sketch note method (FM 6-0)**



### **Step 7: War-game the operation and assess the results.**

War gaming is a conscious attempt to visualize the flow of operations given the friendly force's strengths and disposition, the enemy's capabilities and possible COAs, and civilian locations and activities. During the war game, the commander and staff try to foresee the actions, reactions, and counteractions of all participants, to include civilians. Staff members analyze each selected event. They identify tasks the force must accomplish one echelon down and the use of assets two echelons down. Identifying strengths and weaknesses of each COA allows the staff to adjust the COAs as necessary.

The war game follows an action-reaction-counteraction cycle. Actions are those events initiated by the side with the initiative. (In defensive and stability operations, this is generally the enemy.) Reactions are the opposing side's actions in response. With regard to stability operations, the war game tests the effects of actions, including intended and unintended effects, as it simulates anticipated responses from civilians and civil institutions. Counteractions are the first side's responses to reactions.

The commander and staff examine many areas in detail during the war game to include:

- All friendly capabilities.
- All enemy capabilities.
- Civilian reactions to all friendly (and enemy) actions.
- Global media responses to proposed actions.
- Movement considerations.
- Closure rates.
- Lengths of columns.
- Formation depths.
- Ranges and capabilities of weapon systems.
- Desired effects of fires.

The staff identifies the required assets of the warfighting functions to support the concept of operations, including those needed to synchronize sustaining operations. If requirements exceed available assets, the staff recommends priorities.

The staff considers how to create conditions for success, protect the force, and shape the operational environment. During the war game, staff officers perform a risk assessment for their functional areas for each COA. They then propose appropriate control measures. They continually assess the risk of adverse reactions from population and media resulting from actions taken by all sides in the operation, and develop ways to mitigate those risks.

The commander can modify any COA based on how the war game develops. When doing this, the commander validates the composition and location of the decisive operation, shaping operations, and reserve forces. Control measures are adjusted as necessary. The commander may also identify situations, opportunities, or additional critical events that require more analysis.

### **War-gaming Responsibilities**

The executive officer coordinates actions of the staff during the war game. The XO is the unbiased controller of the process, ensuring the staff stays on a timeline and achieves the goals of the war-gaming session. In a time-constrained environment, the XO ensures that, at a minimum, the decisive operation is war-gamed.

The following paragraphs list the staff members who are involved during the war game and their responsibilities.

### **Intelligence**

The S-2 role-plays the enemy commander. The S-2 develops critical enemy decision points in relation to the friendly COAs, projects enemy reactions to friendly actions, and projects enemy losses. When additional intelligence staff members are available, the intelligence officer assigns different responsibilities to individual staff members within the section for war gaming (such as the enemy commander, friendly intelligence officer, and enemy recorder). The intelligence officer captures the results of each enemy action and counteraction as well as the corresponding friendly and enemy strengths and vulnerabilities. By trying to win the war game for the enemy, the intelligence officer ensures the staff fully addresses friendly responses for each enemy COA. For the friendly force, the S-2:

- Identifies information requirements.
- Refines the situation and event templates, including NAIs that support decision points.
- Refines the event template with corresponding decision points, target areas of interest, and high-value targets.

- Participates in targeting to select high-payoff targets from high-value targets identified during the IPB.
- Recommends PIRs that correspond to the decision points.
- Refines civil considerations overlays, databases, and data files.
- Refines the modified combined obstacle overlays and terrain effects matrices.
- Refines weather products that address the impact on operations.

### **Movement and Maneuver**

The S-3 normally selects the technique for the war game and role-plays the friendly maneuver commander. Various staff officers such as the aviation officer, engineer officer, and red team members assist the S-3. The S-3 executes friendly maneuver as outlined in the COA sketch and COA statement.

The S-5 assesses warfighting requirements, solutions, and concepts for each COA. This plans officer develops plans and orders and determines potential branches and sequels arising from the war gaming of various COAs. The S-5 coordinates and synchronizes warfighting functions in all plans and orders. The planning staff ensures the war game of each COA covers every operational aspect of the mission. The members of the staff record each event's strengths, weaknesses, and the rationale for each action. They complete the decision support template and matrix for each COA.

### **Fires**

The chief of fires (fire support officer) assesses the fire support feasibility of each war-gamed COA. This officer develops a proposed high-payoff target list, target selection standards, and attack guidance matrix. The chief of fires works with the intelligence officer to identify named and target areas of interest for enemy indirect fire weapon systems, and identifies high-payoff targets and additional events that may influence the positioning of field artillery and air defense artillery assets. The chief of fires should also offer a list of possible defended assets for air defense artillery forces and assist the commander in making a final determination about asset priority.

## Protection

The chief of protection assesses protection element requirements, refines EEFI, and develops a scheme of protection for each war-gamed COA.

The chief of protection:

- Refines the critical asset list and the defended asset list.
- Assesses hazards.
- Develops risk control measures and mitigation measures of threats and hazards.
- Establishes personnel recovery coordination measures.
- Implements operational area security to include security of lines of communication (LOCs), anti-terrorism measures, and law enforcement operations.
- Ensures that survivability measures reduce vulnerabilities.
- Refines chemical, biological, radiological, and nuclear operations.

## Sustainment

The S-4 assesses the logistics feasibility of each COA. This officer determines critical requirements for each logistics function (Classes I through VII and IX) and identifies potential problems and deficiencies.

The S-4 assesses the status of all logistics functions required to support the COA, including potential support required to provide essential services to the civilians, and compares them to available assets.

The S-1 assesses the personnel aspect of building and maintaining the combat power of units. This officer identifies potential shortfalls and recommends COAs to ensure units maintain adequate manning to accomplish their missions. The personnel officer estimates potential personnel battle losses and assesses the adequacy of resources to provide human resources support for the operation.

**Note:** The sustainment section should include host-nation security forces and local population battle losses and resource capabilities into war gaming. The S-8 assesses the commander's area of responsibility to determine the best COA for use of resources. This includes both core functions of financial management: resource management and finance operations. This officer determines partner relationships (joint, interagency, intergovernmental, and multinational), requirements for special funding, and support to the procurement process. The surgeon (medical) section provides advice for medically related matters and exercises technical supervision of all medical activities within the AO.

## Mission Command

Mission command is the exercise of authority and direction by the commander using mission orders to enable disciplined initiative within the commander's intent to empower agile and adaptive leaders in the conduct of unified land operations. An effective approach to mission command must be comprehensive, without being rigid, because military operations as a whole defy orderly, efficient, and precise control.

The mission command warfighting function is the related tasks and systems that develop and integrate those activities enabling a commander to balance the art of command and the science of control in order to integrate the other warfighting functions. Throughout the mission command warfighting function, commanders integrate the other warfighting functions into a coherent whole to mass the effects of combat power at the decisive place and time.

All staff proponents have a role in developing the mission command warfighting function tasks and activities. The staff members with the preponderance of the planning requirements for mission command, and their primary tasks during this step of the MDMP, are:

- The signal officer assesses network operations, spectrum management operations, network defense, and information protection feasibility of each war-gamed COA. He determines communications systems requirements and compares them to available assets, identifies potential shortfalls, and recommends actions to eliminate or reduce their effects.
- The information operations officer assesses the information operations concept of support against the ability of information-related capabilities to execute tasks in support of each war-gamed COA. The information operations officer, in coordination with the electronic warfare officer, also integrates information operations with cyber electromagnetic activities.
- The electronic warfare officer provides information on the electronic warfare target list, electronic attack taskings, electronic attack requests, and the electronic warfare portion of the collection matrix and the attack guidance matrix. Additionally, the electronic warfare officer assesses threat vulnerabilities, friendly electronic warfare capabilities, and friendly actions relative to electronic warfare activities and other cyber electromagnetic activities not covered by the S-6 or S-2.

- The S-9 ensures that each war-gamed COA effectively integrates civil considerations (the “C” of METT-TC). The civil affairs operations officer considers not only tactical issues but also sustainment issues. This officer assesses how operations affect civilians and estimates the requirements for essential stability tasks that commanders might have to undertake based on the ability of the unified action partners. Host-nation support and care of dislocated civilians are of particular concern. The civil affairs operations officer’s analysis considers how operations affect public order and safety, the potential for disaster relief requirements, noncombatant evacuation operations, emergency services, and the protection of culturally significant sites. This officer provides feedback on how the culture in the area of operations affects each COA. If the unit lacks an assigned civil affairs officer, the commander assigns these responsibilities to another staff member.

**Note:** Do not become derailed by extraneous minutiae. If the allocation of the assets is appropriate to address a specific situation, then quickly assess the results and continue the process.

An effective war game results in refining:

- Each COA, including identifying branches and sequels that become on-order or be-prepared missions.
- The locations and times of decisive points.
- The enemy event template and matrix.
- The task organization, including forces retained in general support.
- Mission command requirements, including control measures and updated operational graphics.
- CCIRs and information requirements — including the last time information of value — and incorporating them into the information collection plan.

An effective war game results in identifying or confirming:

- Key or decisive terrain and determining how to use it.
- Tasks the unit retains and tasks assigned to subordinates.
- Likely times and areas for enemy use of weapons of mass destruction and friendly chemical, biological, radiological, and nuclear defense requirements.
- Potential times or locations for committing reserve forces.
- The most dangerous enemy COA.

- The most dangerous civilian reaction.
- Locations for the commander, command posts, and information system nodes.
- Critical events.
- Requirements for support of each warfighting function.
- Effects of friendly and enemy actions on civilians and infrastructure and how these will affect military operations.
- The locations of NAIs, target areas of interest, decision points, and information requirements needed to support them.
- Hazards, assessing their risk, developing controls for them, and determining residual risk.
- The coordination required for integrating and synchronizing interagency, host-nation, and nongovernmental organization involvement.

An effective war game results in analyzing:

- Potential civilian reactions to operations.
- Potential media reaction to operations.
- Potential impacts on civil security, civil control, and essential services in the AO.

An effective war game results in developing:

- Decision points.
- A synchronization matrix.
- A decision support template and matrix.
- Solutions to achieving minimum essential stability tasks in the AO.
- The information collection plan and graphics.
- Initial information themes and messages.
- Fires, protection, and sustainment plans and graphic control measures.

An effective war game results in:

- Analyzing and evaluating strengths and weaknesses of each COA.
- Determining requirements for military deception and surprise.
- Determining the timing for concentrating forces and starting the attack or counterattack.

- Determining movement times and tables for critical assets.
- Estimating the duration of the entire operation and each critical event.
- Projecting the percentage of enemy forces defeated in each critical event and overall.
- Projecting the percentage of minimum essential tasks that the unit can or must accomplish.
- Anticipating media coverage and impact on key audiences.
- Integrating targeting into the operation, to include identifying or confirming high-payoff targets and establishing attack guidance.
- Allocating assets to subordinate commanders to accomplish their missions.

### **Step 8: Conduct a war-game briefing (optional).**

If time permits, the staff delivers a briefing to all affected elements to ensure everyone understands the results of the war game. The staff uses the briefing for review and makes sure it captures all relevant points of the war game for presentation to the commander, chief of staff or executive officer, or deputy or assistant commander in the COA decision briefing. In a collaborative environment, the briefing may include selected subordinate staffs. A war-game briefing format includes the following:

- Higher headquarters' mission, commander's intent, and military deception plan.
- Updated IPB.
- Friendly and enemy COAs that were war-gamed, including:
  - Critical events.
  - Possible enemy actions and reactions.
  - Possible impact on civilians.
  - Possible media impacts.
  - Modifications to the COAs.
  - Strengths and weaknesses.
  - Results of the war game.
- Assumptions.
- War-gaming technique used.



## Lessons and Best Practices

**Observation:** Units continue to have difficulty integrating and synchronizing assets into the combined arms fight.

**Discussion:** Units at all levels often are challenged to synchronize the capabilities of their assets to maximize the effectiveness of their force. Synchronization of assets begins with COA development, is refined during COA analysis, and is further refined during rehearsals. Lack of synchronization often results in a disjointed effort, as opposed to operating with unity of effort. Units are challenged to synchronize and coordinate their intelligence efforts, and fires often are not synchronized with obstacles to maximize engagement of the enemy. Key combat multipliers often are piecemealed out during preparation as opposed to organizing the effort based on priority of effort.

**Recommendation:** Course of action analysis is a critical step of the MDMP in which all enablers should participate. An effective war game results in defining the roles of all enablers and warfighting functions and synchronizes their role in the fight. Key products to be developed in the war game include the synchronization matrix, decision support template, and decision support matrix.



## Chapter 7

### Course of Action Comparison

Course of action comparison is an objective process to evaluate COAs independently of each other and against set evaluation criteria approved by the commander and staff. Identifying the strengths and weaknesses of COAs allows for the COA with the highest probability of success to be selected and further developed in an operation plan or operation order. The commander and staff perform certain actions and processes that lead to the key outputs in Figure 7-1.

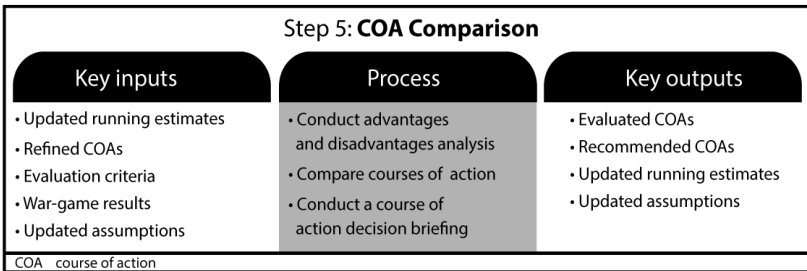

Figure 7-1. COA comparison (FM 6-0)

#### Step 1: Analyze advantages and disadvantages.

COA comparison starts with all staff members analyzing each COA from their perspectives, using the evaluation criteria developed before the war game. Comparing the strengths and weaknesses of the COAs identifies their advantages and disadvantages with respect to each other.

#### Step 2: Compare COAs.

Comparison of COAs is critical. The staff may use any technique that facilitates developing those key outputs and recommendations and helping the commander make the best decision. A common technique is the decision matrix.

<b>Weight<sup>1</sup></b>	<b>1</b>	<b>2</b>	<b>1</b>	<b>1</b>	<b>2</b>	
<b>Criteria<sup>2</sup></b>	Simplicity	Maneuver	Fires	Civil Control	Mass	Total
<b>Course of Action</b>						
<b>Course of Action 1<sup>3</sup></b>	2	2 (4)	2	1	1 (2)	8 (11)
<b>Course of Action 2<sup>3</sup></b>	1	1 (2)	1	2	2 (4)	7 (10)
<b>Notes:</b>						
<sup>1</sup> The COS (XO) may emphasize one or more criteria by assigning weights to them based on a determination of their relative importance. Lower weights are preferred.						
<sup>2</sup> Criteria are those assigned in step 5 COA analysis.						
<sup>3</sup> COAs are those selected for war-gaming with rankings assigned to them based on comparison between them with regard to relative advantages and disadvantages of each, such as when compared for relative simplicity COA 2 is by comparison to COA 1 simpler and therefore is ranked as 1 with COA 1 ranked as 2.						

**Figure 7-2. Decision Matrix (FM 6-0)**

The staff compares feasible COAs to identify the one with the highest probability of success against the most likely enemy COA, the most dangerous enemy COA, the most important stability task, or the most damaging environmental impact. The selected COA should also:

- Pose the minimum risk to the force and mission accomplishment.
- Place the force in the best posture for future operations.
- Provide maximum latitude for initiative by subordinates.
- Provide the most flexibility to meet unexpected threats and opportunities.
- Provide the most secure and stable environment for civilians in the area of operations.
- Best facilitate initial information themes and messages.

### **Step 3: Conduct a COA decision briefing.**

After completing its analysis and comparison, the staff identifies its preferred COA and makes a recommendation. If the staff cannot reach a decision, the XO decides which COA to recommend. The staff then delivers a decision briefing to the commander. The XO highlights any changes to each COA resulting from the war game. The decision briefing includes the following:

- The commander's intent of the higher and next higher commanders.
- The status of the force and its components.
- The current IPB.
- The COAs considered, including:
  - Assumptions used.
  - Results of running estimates.
  - A summary of the war game for each COA, including critical events, modifications to any COA, and war-game results.
  - Advantages and disadvantages (including risk) of each COA.
  - The recommended COA. (If a significant disagreement exists, then the staff should inform the commander and, if necessary, discuss the disagreement.)



## Chapter 8

### Course of Action Approval

After the decision briefing, the commander selects the COA to best accomplish the mission. If the commander rejects all COAs, the staff starts COA development again. If the commander modifies a proposed COA or gives the staff an entirely different one, the staff war-games the new COA and presents the results to the commander with a recommendation.

After approving a COA, the commander issues the final planning guidance. The final planning guidance includes a refined commander's intent (if necessary) and new CCIRs to support execution. It also includes any additional guidance on priorities for the warfighting functions, orders preparation, rehearsal, and preparation. This guidance includes priorities for resources needed to preserve freedom of action and ensure continuous sustainment.

Commanders include the risk they are willing to accept in the final planning guidance. If there is time, commanders use a video teleconference to discuss acceptable risk with adjacent, subordinate, and senior commanders. However, commanders still obtain the higher commander's approval to accept any risk that might imperil accomplishing the higher commander's mission.

Based on the commander's decision and final planning guidance, the staff issues a WARNORD to subordinate headquarters. This WARNORD contains the information subordinate units need to refine their plans. It confirms guidance issued in person or by video teleconference and expands on details not covered by the commander personally. The WARNORD issued after COA approval normally contains:

- The area of operations.
- Mission.
- Commander's intent.
- Updated CCIRs and EEFI.
- Concept of operations.
- Principle tasks assigned to subordinate units.
- The COAs considered, including:
  - Preparation and rehearsal instructions not included in the SOPs.
  - A final timeline for the operations.





## Chapter 9

### Assessments

#### The Assessment Process

Assessment is the determination of the progress toward accomplishing a task, creating an effect, or achieving an objective (JP 3-0). Assessment precedes and guides the other activities of the operations process. Assessment involves deliberately comparing actual events to forecast outcomes to determine the overall effectiveness of force employment. More specifically, assessment helps the commander determine progress toward attaining the desired end state, achieving objectives, and performing tasks. It also involves continuously monitoring and evaluating the operational environment to determine what changes might affect the conduct of operations.

Throughout the operations process, commanders integrate their own assessments with those of the staff, subordinate commanders, and other unified action partners. Primary tools for assessing progress of the operation include the operation order, the common operational picture, personal observations, running estimates, and the assessment plan. The latter includes measures of effectiveness, measures of performance, and reframing criteria. The commander's visualization forms the basis for his personal assessment of progress. Running estimates provide information, conclusions, and recommendations from the perspective of each staff section.

Assessment is continuous; it precedes and guides every operations process activity and concludes each operation or phase of an operation. Broadly, assessment consists of, but is not limited to, the following activities:

- Monitoring the current situation to collect relevant information.
- Evaluating progress toward attaining end-state conditions, achieving objectives, and performing tasks.
- Recommending or directing action for improvement.

#### Monitoring

Monitoring is continuous observation of those conditions relevant to the current operation. Monitoring within the assessment process allows staffs to collect relevant information, specifically information about the current situation that can be compared to the forecast situation described in the commander's intent and concept of operations. Progress cannot be judged, nor effective decisions made, without an accurate understanding of the current situation.

During planning, commanders monitor the situation to develop facts and assumptions that underlie the plan. During preparation and execution, commanders and staffs monitor the situation to determine if the facts are still relevant, if their assumptions remain valid, and if new conditions emerged that affect the operations.

CCIRs and decision points should focus the staff's monitoring activities and prioritize the unit's collection efforts. Information requirements concerning the enemy, terrain and weather, and civil considerations are identified and assigned priorities through reconnaissance and surveillance.

Staffs monitor and collect information from the common operational picture and friendly reports. This information includes operational and intelligence summaries from subordinate, higher, and adjacent headquarters and communications and reports from liaison teams. Staffs also identify information sources outside military channels and monitor their reports. These other channels might include products from civilian, host-nation, and other government agencies. Staffs apply information management and knowledge management to facilitate getting this information to the right people at the right time.

Staff sections record relevant information in running estimates. Staff sections maintain a continuous assessment of current operations as a basis to determine if they are proceeding according to the commander's intent, mission, and concept of operations. In their running estimates, staff sections use this new information and these updated facts and assumptions as the basis for evaluation.

### **Evaluating**

Evaluating is using criteria to judge progress toward desired conditions and determining why the current degree of progress exists. Evaluation is at the heart of the assessment process, where most of the analysis occurs. Evaluation helps commanders determine what is working and what is not working, and it helps them gain insights into how to better accomplish the mission.

Criteria in the forms of measures of effectiveness (MOEs) and measures of performance (MOPs) aid in determining progress toward attaining end-state conditions, achieving objectives, and performing tasks. MOEs help determine if a task is achieving its intended results. MOPs help determine if a task is completed properly. MOEs and MOPs are simply criteria — they do not represent the assessment itself. MOEs and MOPs require relevant information in the form of indicators for evaluation.

A measure of effectiveness is a criterion used to assess changes in system behavior, capability, or operational environment that is tied to measuring the attainment of an end state, achievement of an objective, or creation of an effect (JP 3-0). MOEs help measure changes in conditions, both positive and negative. MOEs help to answer the question “Are we doing the right things?” MOEs are commonly found and tracked in formal assessment plans. Examples of MOEs for the objective to “Provide a safe and secure environment” may include:

- Decrease in insurgent activity.
- Increase in population trust of host-nation security forces.

A measure of performance is a criterion used to assess friendly actions that is tied to measuring task accomplishment (JP 3-0). MOPs help answer questions such as “Was the action taken?” or “Were the tasks completed to standard?” A MOP confirms or denies that a task has been properly performed. MOPs are commonly found and tracked at all levels in execution matrices. MOPs are also commonly used to evaluate training. MOPs help to answer the question “Are we doing things right?”

Current operations integration cells use MOPs in execution matrices and running estimates to track completed tasks. The use of MOPs is a primary element of battle tracking. MOPs focus on the friendly force. Evaluating task accomplishment using MOPs is relatively straightforward and often results in a yes or no answer.

In the context of assessment, an indicator is an item of information that provides insight into a measure of effectiveness or measure of performance. Indicators take the form of reports from subordinates, surveys and polls, and information requirements. Indicators help to answer the question “What is the current status of this MOE or MOP?” A single indicator can inform multiple MOPs and MOEs.

MOE	MOP	Indicator
Answers the question: Are we doing the right things?	Answers the question: Are we doing things right?	Answers the question: What is the status of the MOE or MOP?
Measures purpose accomplishment.	Measures task completion.	Measures raw data inputs to inform MOEs and MOPs.
Measures <i>why</i> in the mission statement.	Measures <i>what</i> in the mission statement.	Information used to make measuring what or why.
No hierarchical relationship to MOPs.	No hierarchical relationship to MOEs.	Subordinate to MOEs and MOPs.
Often formally tracked in formal assessment plans.	Often formally tracked in execution matrices.	Often formally tracked in formal assessment plans.
Typically challenging to choose the correct ones.	Typically simple to choose the correct ones.	Typically as challenging to select correctly as the supported MOE or MOP.

**Figure 9-1. Assessment measures and indicators (ADRP 5-0)**

Evaluation includes analysis of why progress is or is not being made according to the plan. Commanders and staffs propose and consider possible causes. In particular, the question of whether changes in the situation can be attributed to friendly actions is addressed. Commanders and staffs consult subject matter experts, both internal and external to the staff, on whether staffs have identified the correct underlying causes for specific changes in the situation. Assumptions identified in the planning process are challenged to determine if they are still valid.

A key aspect of evaluation is determining variances — the difference between the actual situation and what the plan forecast the situation would be at the time or event. Based on the significance of the variances, the staff makes recommendations to the commander on how to adjust operations to accomplish the mission more effectively.

Evaluating includes considering whether the desired conditions have changed, are no longer achievable, or are not achievable through the current operational approach. This is done by continually challenging the key assumptions made when framing the problem. When an assumption is invalidated, then reframing may be in order.

Monitoring and evaluating are critical activities; however, assessment is incomplete without recommending or directing action. Assessment may diagnose problems, but unless it results in recommended adjustments, its use to the commander is limited.

Based on the evaluation of progress, the staff brainstorms possible improvements to the plan and makes preliminary judgments about the relative merit of those changes. Staff members identify those changes possessing sufficient merit and provide them as recommendations to the commander or make adjustments within their delegated authority. Recommendations to the commander range from continuing the operation as planned, to executing a branch, or making unanticipated adjustments. Making adjustments includes assigning new tasks to subordinates, reprioritizing support, adjusting information collection assets, and significantly modifying the course of action. Commanders integrate recommendations from the staff, subordinate commanders, and other partners with their personal assessment. Using those recommendations, they decide if and how to modify the operation to better accomplish the mission.

Although establishing cause and effect is sometimes difficult, it is crucial to effective assessment. Sometimes, establishing causality between actions and their effects can be relatively straightforward, such as in observing a bomb destroy a bridge. In other instances, especially regarding changes in human behavior, attitudes, and perception, establishing links between cause and effect proves difficult. Commanders and staffs must guard against drawing erroneous conclusions in these instances.

Effective assessment incorporates both quantitative (observation-based) and qualitative (opinion-based) indicators. Human judgment is integral to assessment. A key aspect of any assessment is the degree to which it relies on human judgment and the degree to which it relies on direct observation and mathematical rigor. Rigor offsets the inevitable bias, while human judgment focuses rigor and processes on intangibles that are often key to success. The appropriate balance depends on the situation, particularly the nature of the operation and available resources for assessment, but rarely lies at the ends of the scale.



## Chapter 10

### Operations Order

The operations order serves as a directive to subordinate units to relay the commander's orders. It is intended to coordinate the activities of all organizations participating in the specified mission.

The S-3 section prepares, coordinates, authenticates, reviews, publishes, and distributes written operations orders and plans. The operations officer must be firmly in charge of the OPORD process. He should serve as the unifying force for the rest of the staff routinely works with to generate a product that is concise yet informative to subordinate leaders. Each staff section will produce an annex to the main order containing information pertinent to its field of expertise. The S-3 must ensure these annexes are completed in time for review and publication with the base order.

Normally, the XO coordinates with staff primaries to assist the S-3 in developing the OPLAN or OPORD. Based on the commander's planning guidance, the XO:

- Dictates the type of order to be issued.
- Sets and enforces the orders production timeline.
- Determines which staff sections publish which portions of the order.

Prior to the commander's approving the OPLAN or OPORD, the XO and S-3 along with the rest of the staff ensures it is internally consistent and is nested with the higher commander's intent, which is done through:

- Plans and orders reconciliation.
- Plans and orders crosswalk.

The following is an example of a way to format a typical OPLAN/OPORD.

---

Copy # of # copies

Issuing headquarters

Place of issue

Date-time group of signature

Message reference number

OPLAN/OPORD (Number) [(Code name)] [(Classification of title)]

(UNCLASSIFIED [U]) References:

(U) Time Zone Used Throughout the OPLAN/OPORD:

(U) Task Organization:

**1. (U) Situation**

a. (U) Area of Interest

b. (U) Area of Operations

(1) (U) Terrain

(2) (U) Weather

c. (U) Enemy Forces

d. (U) Friendly Forces

(1) (U) Higher Headquarters' Mission and Intent

(a) (U) Higher Headquarters Two Levels Up.

(b) (U) Higher Headquarters

(2) (U) Missions of Adjacent Units

e. (U) Interagency, Intergovernmental, and Nongovernmental Organizations

f. (U) Civil Considerations

g. (U) Attachments and Detachments

h. (U) Assumptions

**2. (U) Mission**



**3. (U) Execution**

- a. (U) Commander's Intent
- b. (U) Concept of Operations
- c. (U) Scheme of Movement and Maneuver
  - (1) (U) Scheme of Mobility/Counter-mobility
  - (2) (U) Scheme of Battlefield Obscuration
  - (3) (U) Scheme of Information Collection
- d. (U) Scheme of Intelligence
- e. (U) Scheme of Fires
- f. (U) Scheme of Protection
- g. (U) Cyber Electromagnetic Activities
- h. (U) Stability Tasks
- i. (U) Assessment
- j. (U) Tasks to Subordinate Units
- k. (U) Coordinating Instructions
  - (1) (U) Time or condition when the OPORD becomes effective
  - (2) (U) Commander's Critical Information Requirements
  - (3) (U) Essential Elements of Friendly Information
  - (4) (U) Fire Support Coordination Measures
  - (5) (U) Airspace Coordinating Measures
  - (6) (U) Rules of Engagement
  - (7) (U) Risk Reduction Control Measures
  - (8) (U) Personnel Recovery Coordination Measures
  - (9) (U) Environmental Considerations
  - (10) (U) Soldier and Leader Engagement
  - (11) (U) Other Coordinating Instructions

**4. (U) Sustainment**

- a. (U) Logistics
- b. (U) Personnel
- c. (U) Health Service Support

**5. (U) Command and Control**

- a. (U) Command
  - (1) (U) Location of Commander and Key Leaders
  - (2) (U) Succession of Command
  - (3) (U) Liaison Requirements
- b. (U) Control
  - (1) (U) Command Posts
  - (2) (U) Reports
- c. (U) Signal

ACKNOWLEDGE:

(Commander's Last Name)

(Commander's Rank)

(The commander or authorized representative signs the original copy. If the representative signs the original, add the phrase "For the Commander." The signed copy is the historical copy and remains in the headquarters' files.)

OFFICIAL:

(Authenticator's Last Name)

(Authenticator's Rank)

(Use only if the commander does not sign the original order. If the commander signs the original, no further authentication is required. If the commander does not sign, the signature of the preparing staff officer requires authentication and only the last name and rank of the commander appear in the signature block.)

ANNEXES:

- A – Task Organization
- B – Intelligence
- C – Operations
- D – Fires
- E – Protection
- F – Sustainment
- G – Engineer
- H – Signal
- I – Not used
- J – Public Affairs
- K – Civil Affairs Operations
- L – Information Collection
- M – Assessment
- N – Space Operations
- O – Not used
- P – Host-Nation Support
- Q – Knowledge Management
- R – Reports
- S – Special Technical Operations
- T – Spare
- U – Inspector General
- V – Interagency Coordination
- W – Operational Contract Support
- X – Not used
- Y – Not used
- Z – Distribution

DISTRIBUTION: (Furnish distribution copies either for action or for information. List in detail those who are to receive the plan or order. Refer to Annex Z (Distribution) if lengthy.)

---

## **Annexes Explained**

### **ANNEX A – TASK ORGANIZATION (S-3 or S-5)**

#### **ANNEX B – INTELLIGENCE (S-2)**

##### Appendix 1 – Intelligence Estimate

Tab A – Terrain (Engineer Officer)

Tab B – Weather (Staff Weather Officer)

Tab C – Civil Considerations

Tab D – Intelligence Preparation of the Battlefield Products

##### Appendix 2 – Counterintelligence

##### Appendix 3 – Signals Intelligence

##### Appendix 4 – Human Intelligence

##### Appendix 5 – Geospatial Intelligence

##### Appendix 6 – Measurement and Signature Intelligence

### **ANNEX C – OPERATIONS (S-3 or S-5)**

##### Appendix 1 – Army Design Methodology Products

##### Appendix 2 – Operations Overlay

##### Appendix 3 – Decision Support Products

Tab A – Execution Matrix

Tab B – Decision Support Template and Matrix

##### Appendix 4 – Gap Crossing Operations

##### Appendix 5 – Air Assault Operations

##### Appendix 6 – Airborne Operations

##### Appendix 7 – Amphibious Operations

##### Appendix 8 – Special Operations (S-3)

##### Appendix 9 – Battlefield Obscuration (CBRN Officer)

##### Appendix 10 – Airspace Command and Control (S-3 or Airspace Command and Control Officer)

##### Appendix 11 – Rules of Engagement (Staff Judge Advocate)

Tab A – No-Strike List (S-3 with Staff Judge Advocate)

Tab B – Restricted Target List (S-3 with Staff Judge Advocate)

Appendix 12 – Cyber Electromagnetic Activities  
(Electronic Warfare Officer)

Appendix 13 – Military Information Support Operations  
(Military Information Support Officer)

Appendix 14 – Military Deception (Military Deception Officer)

Appendix 15 – Information Operations (Information Operations Officer)

**ANNEX D – FIRES (Chief of Fires)**

Appendix 1 – Fire Support Overlay

Appendix 2 – Fire Support Execution Matrix

Appendix 3 – Targeting

Tab A – Target Selection Standards

Tab B – Target Synchronization Matrix

Tab C – Attack Guidance Matrix

Tab D – Target List Work Sheets

Tab E – Battle Damage Assessment (S-2)

Appendix 4 – Field Artillery Support

Appendix 5 – Air Support

Appendix 6 – Naval Fire Support

Appendix 7 – Air and Missile Defense (Air and Missile Defense Officer)

Tab A – Enemy Air Avenues of Approach

Tab B – Enemy Air Order of Battle

Tab C – Enemy Theater Ballistic Missile Overlay

Tab D – Air and Missile Defense Protection Overlay

**ANNEX E – PROTECTION (Chief of Protection/Protection  
Coordinator as designated by the commander)**

Appendix 1 – Operational Area Security

Appendix 2 – Safety (Safety Officer)

Appendix 3 – Operations Security

Appendix 4 – Intelligence Support to Protection

Appendix 5 – Physical Security

Appendix 6 – Antiterrorism

Appendix 7 – Police Operations

Appendix 8 – Survivability Operations

Appendix 9 – Force Health Protection

Appendix 10 – Chemical, Biological, Radiological,  
and Nuclear Defense (CBRN Officer)

Appendix 11 – Explosive Ordnance Disposal (EOD Officer)

Appendix 12 – Coordinate Air and Missile Defense (Air Defense Officer)

Appendix 13 – Personnel Recovery (Personnel Recovery Officer)

Appendix 14 – Detainee and Resettlement

**ANNEX F – SUSTAINMENT (Chief of Sustainment [S-4])**

Appendix 1 – Logistics (S-4)

Tab A – Sustainment Overlay

Tab B – Maintenance

Tab C – Transportation

Exhibit 1 – Traffic Circulation and Control  
(Provost Marshal)

Exhibit 2 – Traffic Circulation Overlay

Exhibit 3 – Road Movement Table

Exhibit 4 – Highway Regulation (Provost Marshal)

Tab D – Supply

Tab E – Field Services

Tab F – Distribution

Tab G – Contract Support Integration

Tab H – Mortuary Affairs

Appendix 2 – Personnel Services Support

Tab A – Human Resources Support (S-1)

Tab B – Financial Management (S-8)

Tab C – Legal Support (Staff Judge Advocate)

Tab D – Religious Support (Chaplain)

Tab E – Band Operations (S-1)

Appendix 3 – Health Service Support (Surgeon)

**ANNEX G – ENGINEER (Engineer Officer)**

Appendix 1 – Mobility/Counter-mobility

Tab A – Obstacle Overlay

Appendix 2 – Survivability

Appendix 3 – General Engineering

Appendix 4 – Geospatial Engineering

Appendix 5 – Environmental Considerations

**ANNEX H – SIGNAL (S-6)**

Appendix 1 – Defensive Cyberspace Operations

Appendix 2 – Information Network Operations

Appendix 3 – Voice, Video, and Data Network Diagrams

Appendix 4 – Satellite Communication

Appendix 5 – Foreign Data Exchanges

Appendix 6 – Spectrum Management Operations

Appendix 7 – Information Services

**ANNEX I – Not Used**

**ANNEX J – PUBLIC AFFAIRS (Public Affairs Officer)**

Appendix 1 – Public Affairs Running Estimate

Appendix 2 – Public Affairs Guidance

**ANNEX K – CIVIL AFFAIRS OPERATIONS (S-9)**

Appendix 1 – Execution Matrix

Appendix 2 – Populace and Resources Control Plan

Appendix 3 – Civil Information Management Plan

**ANNEX L – INFORMATION COLLECTION (S-3)**

Appendix 1 – Information Collection Plan

Appendix 2 – Information Collection Overlay

**ANNEX M – ASSESSMENT (S-3 or S-5)**

Appendix 1 – Nesting of Assessment Efforts

Appendix 2 – Assessment Framework

Appendix 3 – Assessment Working Group

**ANNEX N – SPACE OPERATIONS (Space Operations Officer)**

**ANNEX O – Not Used**

**ANNEX P – HOST-NATION SUPPORT (S-4)**

**ANNEX Q – KNOWLEDGE MANAGEMENT  
(Knowledge Management Officer)**

Appendix 1 – Knowledge Management Decision Support Matrix

Appendix 2 – Common Operational Picture Configuration Matrix

Appendix 3 – Mission Command Information Systems Integration Matrix

Appendix 4 – Content Management

Appendix 5 – Battle Rhythm

**ANNEX R – REPORTS (S-3)**

**ANNEX S – SPECIAL TECHNICAL OPERATIONS**

Appendix 1 – Special Technical Operations Capabilities Integration Matrix

Appendix 2 – Functional Area I Program and Objectives

Appendix 3 – Functional Area II Program and Objectives

**ANNEX T – Spare**

**ANNEX U – INSPECTOR GENERAL**

**ANNEX V – INTERAGENCY COORDINATION (S-3)**

**ANNEX W – OPERATIONAL CONTRACT SUPPORT (S-4)**

**ANNEX X – Spare**

**ANNEX Y – Spare**

**ANNEX Z – DISTRIBUTION (S-3)**



## Lessons and Best Practices

**Observation:** Units are often challenged to write and publish quality WARNORDs, FRAGORDs, and OPORDs.

**Discussion:** Observations from recent CTC rotations show that units often neglect to conduct a thorough MDMP for upcoming missions. Most units produce a daily FRAGORD that is simply a cut and paste from the higher headquarters' order. Various FRAGORD writers are often identified during an exercise, including the Planner, the JAG, and the S-6. The confusion resulting from an unclear orders-writing procedure hampers situational understanding among the staff and with subordinate units.

**Recommendation:** Clearly delineate the orders-writing procedure in the SOP. A clear understanding among the staff on how orders are staffed and written will enhance situational understanding across the command post.

---

**Observation:** A lack of staff integration during the orders process hinders the unit's ability to produce a complete operations order (OPORD)/fragmentary order (FRAGORD).

**Discussion:** Many units have difficulty in bringing all of the individual staff efforts together into a coordinated planning effort, and do not establish formal touch points or synchronization meetings for the purpose of revising and refining plans with inputs from all of the warfighting functions.

**Recommendation:** Conduct daily (or as needed) staff planning meetings in order to disseminate commander's guidance, receive operational updates, integrate warfighting functions, and guide the operations process. Update the unit TACSOP with a synchronization matrix that includes all warfighting functions.

After the order is issued, the commander and staff participate in formal or informal confirmation briefing(s), as required, with subordinate staffs. This ensures that subordinate staffs understand the commander's intent and concept.

The staff assists subordinate staffs by reviewing subordinate commander's plans and orders upon completion, and integrating subordinate graphics into the staff products.



## Chapter 11

### Rehearsals

Rehearsals allow leaders and their Soldiers to practice key aspects of the concept of operations. These actions help Soldiers orient themselves to their environment and other units before executing the operation. Rehearsals help Soldiers build a lasting mental picture of the sequence of key actions within the operation.

Rehearsals are the commander's tool to ensure staffs and subordinates understand the commander's intent and the concept of operations. They allow commanders and staffs to identify shortcomings in the plan not previously recognized. Rehearsals also contribute to external and internal coordination, as the staff identifies additional coordinating requirements.

Effective and efficient units habitually rehearse during training. Commanders at every level routinely train and practice various rehearsal types. Local standard operating procedures (SOPs) identify appropriate rehearsal types and standards for their execution. All leaders conduct periodic after-action reviews to ensure their units conduct rehearsals to standard and correct substandard performances. After-action reviews also enable leaders to incorporate lessons learned into existing plans and orders, or into subsequent rehearsals.

Units conduct rehearsals at the lowest possible level, using the most thorough technique possible, given the time available. Under time-constrained conditions, leaders conduct abbreviated rehearsals, focusing on critical events determined by reverse planning. Each unit will have different critical events based on the mission, unit readiness, and the commander's assessment.

#### Rehearsal Types

Each rehearsal type achieves a different result and has a specific place in the preparation timeline. The four types of rehearsals are the:

- Back brief.
- Combined arms rehearsal.
- Support rehearsal.
- Battle drill or SOP rehearsal.

## **Back Brief**

A back brief is a briefing by subordinates to the commander to review how subordinates intend to accomplish their mission. Normally, subordinates perform back briefs throughout preparation. These briefings allow commanders to clarify the commander's intent early in subordinate planning. Commanders use the back brief to identify any problems in the concept of operations.

The back brief differs from the confirmation brief (a briefing subordinates give their higher commander immediately following receipt of an order) in that the back brief gives subordinate leaders time to complete their plan. Back briefs require the fewest resources and are often the only option under time-constrained conditions. Subordinate leaders explain their actions from the start to the finish of the mission. Back briefs are performed sequentially, with all leaders reviewing their tasks. When time is available, back briefs can be combined with other types of rehearsals. Doing this lets all subordinate leaders coordinate their plans before performing more elaborate drills.

## **Combined Arms Rehearsal**

A combined arms rehearsal is a rehearsal in which subordinate units synchronize their plans with each other. A maneuver unit headquarters normally executes a combined arms rehearsal after subordinate units issue their OPORD. This rehearsal type helps ensure that subordinate commanders' plans achieve the higher commander's intent.

## **Support Rehearsal**

The support rehearsal helps synchronize each warfighting function with the overall operation. This rehearsal supports the operation so units can accomplish their missions. Throughout preparation, units conduct support rehearsals within the framework of a single or limited number of warfighting functions. These rehearsals typically involve coordination and procedure drills for aviation, fires, engineer support, or casualty evacuation. Support rehearsals and combined arms rehearsals complement preparations for the operation. Units may conduct rehearsals separately and then combine them into full-dress rehearsals. Although these rehearsals differ slightly by warfighting function, they achieve the same result.

## **Battle Drill or SOP Rehearsal**

A battle drill is a collective action rapidly executed without a deliberate decisionmaking process. A battle drill or SOP rehearsal ensures that all participants understand a technique or a specific set of procedures. Throughout preparation, units and staffs rehearse battle drills and SOPs. These rehearsals do not need a completed order from higher headquarters. Leaders place priority on those drills or actions they anticipate occurring during the operation.

## Rehearsal Responsibilities

### Commander

Commanders provide certain information as part of the commander's guidance during the initial mission analysis. They may revise the following information when they select a course of action:

- Rehearsal type.
- Rehearsal technique.
- Location.
- Attendees.
- Enemy course of action to be portrayed.

### Executive Officer

The executive officer ensures all rehearsals are included in the organization's time-management SOP. The XO responsibilities include:

- Publishing the rehearsal time and location in the OPORD or WARNORD.
- Conducting staff rehearsals.
- Determining rehearsal products, based on type, technique, and mission variables.
- Coordinating liaison officer attendance from adjacent units.

## Rehearsal Preparation

Everyone involved in executing or supporting the rehearsal has responsibilities during preparation.

### Executive Officer

The XO through war-gaming and coordination with the commander:

- Prepares to serve as the rehearsal director.
- Coordinates time for key events requiring rehearsal.
- Establishes rehearsal time limits per the commander's guidance and mission variables.
- Verifies rehearsal site preparation, appropriate markings and associated training aids, and parking areas.
- Determines the method for controlling the rehearsal and ensuring its logical flow.

## **Subordinate Leaders**

Subordinate leaders complete their planning. This planning includes:

- Completing unit OPORDs.
- Identifying issues derived from the higher headquarters' OPORD.
- Providing a copy of their unit OPORD with graphics to the higher headquarters.
- Ensuring they and their subordinates bring all necessary equipment.

## **Conducting Headquarters Staff**

Conducting headquarters staff members:

- Develop an OPORD with necessary overlays.
- Deconflict all subordinate unit graphics.
- Publish composite overlays at the rehearsal, including at a minimum: Movement and maneuver, intelligence, fires, sustainment, signal operations, and protection.

## **Rehearsal Execution**

During the rehearsal execution, the commander, XO, assistants, subordinate leaders, recorder, and staff from the conducting headquarters have specific responsibilities.

### **Commander**

Commanders command the rehearsal just as they will command the operation. They maintain the focus and level of intensity, allowing no potential for subordinate confusion. Although the staff refines the OPORD, it belongs to the commander. The commander uses the order to conduct operations. An effective rehearsal is not a commander's briefing to subordinates. It validates synchronization — the what, when, and where — of tasks that subordinate units will perform to execute the operation and achieve the commander's intent.

### **Executive Officer**

Normally, the XO serves as the rehearsal director. This officer ensures each unit will accomplish its tasks at the right time and cues the commander to upcoming decisions. The executive officer's script is the execution matrix and the decision support template. The XO as the rehearsal director:

- Starts the rehearsal on time.
- Has a formal roll call.

- Ensures everyone brings the necessary equipment, including organizational graphics and previously issued orders.
- Validates the task organization. Link-ups must be complete or on schedule, and required materiel and personnel must be on hand. The importance of this simple check cannot be overemphasized.
- Ensures synchronization of the operational framework being used.
- Rehearses the synchronization of combat power from flank and higher organizations. These organizations often exceed the communications range of the commander when they are away from the command post.
- Synchronizes the timing and contribution of each warfighting function.
- For each decisive point, defines conditions required to commit the reserve or striking forces, move a unit, close or emplace an obstacle, fire at planned targets, or change the posture of sustainment activities.
- Disciplines leader movements, enforces brevity, and ensures completeness.
- Keeps within time constraints.
- Ensures that the most important events receive the most attention.
- Ensures that absentees and flank units receive changes to the OPORD and transmits changes to them as soon as practical.
- Communicates the key civil considerations of the operation.

### **Operations Officer (S-3)**

- Portrays the friendly scheme of maneuver.
- Ensures subordinate unit actions comply with the commander's intent.
- Normally provides the recorder.

### **Intelligence Officer (S-2)**

The intelligence officer portrays the enemy forces and other variables of the operational environment during rehearsals. The S-2 bases actions on the enemy course of action that the commander selected during the MDMP. The S-2:

- Provides participants with current intelligence.
- Portrays the best possible assessment of the enemy course of action.
- Communicates the enemy's presumed concept of operations, desired effects, and end state.

- Explains other factors of the operational environment that may hinder or complicate friendly actions.
- Communicates the key civil considerations of the operation.

### **Subordinate Leaders**

Subordinate unit leaders, using an established format, effectively articulate their unit's actions and responsibilities as well as record changes on their copies of the graphics or OPORD.

### **Recorder**

The recorder is normally a representative from the S-3. During the rehearsal, the recorder captures all coordination made during execution and notes unresolved problems. At the end of the rehearsal, the recorder presents any unresolved problems for resolution, restates any changes directed by the commander, and estimates when a fragmentary order codifying the changes will follow.

### **Rehearsal Details**

All participants have responsibilities before, during, and after a rehearsal.

Before a rehearsal, the rehearsal director states the commander's expectations and orients the other participants on details of the rehearsal, as necessary. During a rehearsal, all participants rehearse their roles in the operation. They make sure they understand how their actions support the overall operation and note any additional coordination required. After a rehearsal, participants ensure they understand any changes to the OPORD and coordination requirements, and they receive all updated staff products.

Commanders do not normally address small problems that arise during rehearsals. Instead, the recorder keeps a record of these problems. This ensures the commander does not interrupt the rehearsal's flow. If the problem remains at the end of the rehearsal, the commander resolves it then. If the problem jeopardizes mission accomplishment, the staff accomplishes the coordination necessary to resolve it before the participants disperse. Identifying and solving such problems is a major reason for conducting rehearsals. If commanders do not make corrections while participants are assembled, they may lose the opportunity to do so. Coordinating among dispersed participants and disseminating changes to them often prove more difficult than accomplishing these actions in person.



## **Before the Rehearsal**

Before the rehearsal, the rehearsal director calls the roll and briefs participants on information needed for execution. The briefing begins with an introduction, overview, and orientation. It includes a discussion of the rehearsal script and ground rules. The detail of this discussion is based on participants' familiarity with the rehearsal SOP.

## **Introduction and Overview**

Before the rehearsal, the rehearsal director introduces all participants as needed. Then, the rehearsal director (normally the XO) gives an overview of the briefing topics, rehearsal subjects and sequence, and timeline, specifying the no-later-than ending time. The rehearsal director explains any constraints, such as pyrotechnics use, light discipline, weapons firing, or radio silence. For safety, the rehearsal director ensures all participants understand safety precautions and enforces their use. Last, the director emphasizes results and states the commander's standard for a successful rehearsal. Subordinate leaders state any results of planning or preparation (including rehearsals) they have already conducted. If a subordinate recommends a change to the OPORD, the rehearsal director acts on the recommendation before the rehearsal begins, if possible. If not, the commander resolves the recommendation with a decision before the rehearsal ends.

## **Orientation**

The rehearsal director orients the participants to the terrain or rehearsal medium. The rehearsal director identifies orientation using magnetic north on the rehearsal medium and symbols representing actual terrain features. After explaining any graphic control measures, obstacles, and targets, the rehearsal director issues supplemental materials, if needed.

## **Rehearsal Script**

An effective means for the rehearsal director to control rehearsals is the use of a script. It keeps the rehearsal on track. The script provides a checklist so the organization addresses all warfighting functions and outstanding issues. It has two major parts: the agenda and response sequence.

## **Agenda**

An effective rehearsal follows a prescribed agenda that everyone knows and understands. This agenda includes, but is not limited to:

- Roll call.
- Participant orientation to the terrain.
- Location of local civilians.

- Enemy situation brief.
- Friendly situation brief.
- Description of expected enemy actions.
- Discussion of friendly unit actions.
- A review of notes made by the recorder.

The execution matrix, decision support template, and OPORD outline the rehearsal agenda. These tools, especially the execution matrix, both drive and focus the rehearsal. The commander and staff use them to control the operation's execution. Any templates, matrices, or tools developed within each of the warfighting functions should tie directly to the supported unit's execution matrix and decision support template. Examples include an intelligence synchronization matrix or fires execution matrix.

An effective rehearsal realistically and quickly portrays the enemy force and other variables of the operational environment without distracting from the rehearsal. One technique for doing this has the S-2 preparing an actions checklist. It lists a sequence of events much like the one for friendly units, but from the enemy or civilian perspective.

### **Response Sequence**

Participants respond in a logical sequence: either by warfighting function or by unit as the organization deploys, from front to rear. The commander determines the sequence before the rehearsal. The staff posts the sequence at the rehearsal site, and the rehearsal director may restate it.

Effective rehearsals allow participants to visualize and synchronize the concept of operations. As the rehearsal proceeds, participants talk through the concept of operations. They focus on key events and the synchronization required to achieve the desired effects. The commander leads the rehearsal and gives orders during the operation. Subordinate commanders enter and leave the discussion at the time they expect to begin and end their tasks or activities during the operation. This practice helps the commander assess the adequacy of synchronization. Commanders do not "re-war-game" unless absolutely necessary to ensure subordinate unit commanders understand the plan.

The rehearsal director emphasizes integrating fires, events that trigger different branch actions, and actions on contact. The chief of fires (fire support officer) or firing unit commander states when to initiate fires, who to fire them, from where the firing comes, the ammunition available, and the desired target effect. Subordinate commanders state when they initiate fires per their fire support plans. The rehearsal director speaks for any absent staff section and ensures the rehearsal addresses all actions on the synchronization matrix and decision support template at the proper time or event.

The rehearsal director ensures that the rehearsal includes key sustainment and protection actions at the appropriate times. Failure to do so reduces the value of the rehearsal as a coordination tool. The staff officer with coordinating staff responsibility inserts these items into the rehearsal. Special staff officers should brief by exception when a friendly or enemy event occurs within their area of expertise. Summarizing these actions at the end of the rehearsal can reinforce coordination requirements identified during the rehearsal. The staff updates the decision support template and gives a copy to each participant.

Under time-constrained conditions, the conducting headquarters staff may provide copies before the rehearsal and rely on participants to update them with pen-and-ink changes.

### **Ground Rules**

After discussing the rehearsal script, the rehearsal director:

- States the standard (what the commander will accept) for a successful rehearsal.
- Ensures everyone understands the parts of the OPORD to rehearse. If the unit will not rehearse the entire operations, the rehearsal director states the events to be rehearsed.
- Quickly reviews the rehearsal SOP if all participants are not familiar with it.
- Establishes the timeline that designates the rehearsal starting time in relation to H-hour. For example, begin the rehearsal by depicting the anticipated situation one hour before H-hour.
- Establishes the time interval to begin and track the rehearsal. For example, a 10-minute interval equates to one hour of actual time.
- Updates friendly and enemy activities as necessary; for example, describing any ongoing reconnaissance.

### **During the Rehearsal**

Once the rehearsal director finishes discussing the ground rules and answering questions, the S-3 reads the mission statement, the commander reads the commander's intent, and the S-3 establishes the current friendly situation. The rehearsal then begins, following the rehearsal script.

### **Step 1 – Enemy Forces Deployed**

The S-2 briefs the current enemy situation and operational environment and places markers on the map or terrain board (as applicable) indicating where enemy forces and other operationally significant groups or activities would be before the first rehearsal event. The S-2 then briefs the most likely enemy course of action and operational context. The S-2 also briefs the status of information collection operations (for example, citing any patrols still out or any observation post positions).

### **Step 2 – Friendly Forces Deployed**

The S-3 briefs friendly maneuver unit dispositions, including security forces, as they are arrayed at the start of the operation. Subordinate commanders and other staff officers brief their unit positions at the starting time and any particular points of emphasis. For example, the chemical, biological, radiological, and nuclear (CBRN) officer states the mission-oriented protective posture level, and the fire support officer or fires unit commander states the range of friendly and enemy artillery. Other participants place markers for friendly forces, including adjacent units, at the positions they will occupy at the start of the operation. As participants place markers, they state their task and purpose, task organization, and strength.

Sustainment and protection units brief positions, plans, and actions at the starting time and at points of emphasis the rehearsal director designates. Subordinate units may include forward arming and refueling points, refuel-on-the-move points, communications checkpoints, security points, or operations security procedures that differ for any period during the operation. The rehearsal director restates the commander's intent, if necessary.

### **Step 3 – Initiate Action**

The rehearsal director states the first event on the execution matrix. Normally this involves the S-2 moving enemy markers according to the most likely course of action. The depiction must tie enemy actions to specific terrain or to friendly unit actions. The S-2 portrays enemy actions based on the situational template developed for staff war gaming.

As the rehearsal proceeds, the S-2 portrays the enemy and other operational factors and walks through the most likely enemy course of action (per the situational template). The S-2 stresses reconnaissance routes, objectives, security force composition and locations, initial contact, initial fires (artillery, air, and attack helicopters), probable main force objectives or engagement areas, and likely commitment of reserve forces.

### **Step 4 – Decision Point**

When the rehearsal director determines that a particular enemy movement or reaction is complete, the commander assesses the situation to determine if a decision point has been reached. Decision points are taken directly from the decision support template.

If the commander determines the unit is not at a decision point and not at the end state, the commander directs the rehearsal director to continue to the next event on the execution matrix. Participants use the response sequence and continue to act out and describe their unit's actions.

When the rehearsal reaches conditions that establish a decision point, the commander decides whether to continue with the current course of action or select a branch course of action. If electing the current course of action, the commander directs the rehearsal director to move to the next event in the execution matrix. If selecting a branch, the commander states the reason for selecting that branch, states the first event of that branch, and continues the rehearsal until the organization has rehearsed all events of that branch. As the unit reaches decisive points, the rehearsal director states the conditions required for success.

When it becomes obvious that the operation requires additional coordination to ensure success, participants immediately begin coordinating. This is one of the key reasons for rehearsals. The rehearsal director ensures that the recorder captures the coordination and any changes and that all participants understand the coordination.

### **Step 5 – End State Reached**

Achieving the desired end state completes that phase of the rehearsal. In an attack, this will usually be when the unit is on the objective and has finished consolidation and casualty evacuation. In the defense, this will usually be after the decisive action (such as committing the reserve or striking force), the final destruction or withdrawal of the enemy, and casualty evacuation are complete. In stability tasks, this usually occurs when a unit achieves the targeted progress within a designated line of effort.

### **Step 6 – Reset**

At this point, the commander states the next branch to rehearse. The rehearsal director resets the situation to the decision point where that branch begins and states the criteria for a decision to execute that branch. Participants assume those criteria have been met and then refight the operation along that branch until they attain the desired end state. They complete any coordination needed to ensure all participants understand and can meet any requirements. The recorder records any changes to the branch.

The commander then states the next branch to rehearse. The rehearsal director again resets the situation to the decision point where that branch begins, and participants repeat the process. This continues until the rehearsal has addressed all decision points and branches that the commander wants to rehearse.

If the standard is not met and time permits, the commander directs participants to repeat the rehearsal. The rehearsal continues until participants are prepared or until the time available expires. (Commanders may allocate more time for a rehearsal but must assess the effects on subordinate commanders' preparation time.) Successive rehearsals, if conducted, should be more complex and realistic.

At the end of the rehearsal, the recorder restates any changes, coordination, or clarifications that the commander directed and estimates how long it will take to codify changes in a written FRAGORD.

### **After the Rehearsal**

After the rehearsal, the commander leads an after-action review. The commander reviews lessons learned and makes the minimum required modifications to the existing plan. (Normally, a FRAGORD effects these changes.) Changes should be refinements to the OPORD; they should not be radical or significant. Changes not critical to the operation's execution may confuse subordinates and hinder the synchronization of the plan. The commander issues any last-minute instructions or reminders and reiterates the commander's intent.

Based on the commander's instructions, the staff makes any necessary changes to the OPORD, decision support template, and execution matrix based on the rehearsal results. Subordinate commanders incorporate these changes into their unit's OPORDs. The COS (XO) ensures the changes are briefed to all leaders or liaison officers who did not participate in the rehearsal.

A rehearsal provides the final opportunity for subordinates to identify and fix unresolved problems. The staff ensures that all participants understand any changes to the OPORD and that the recorder captures all coordination done at the rehearsal. All changes to the published OPORD are, in effect, oral FRAGORDs. As soon as possible, the staff publishes them as a written FRAGORD that changes the operation order.

## Lessons and Best Practices

**Observation:** Fires rehearsals are often ineffective or not conducted.

**Discussion:** A noted trend at the CTCs indicates that many unit fires cells and commanders do not have a clear understanding of how to conduct effective fires rehearsals, both as part of the combined arms rehearsal (CAR) and as technical fire support rehearsals. Rehearsals and back briefs occur during preparation and ensure an orderly transition between planning and execution. Rehearsals also allow leaders to assess their subordinates' preparations.

**Recommendation:** Use the CAR to enable commanders and staffs to visualize the concept of operations and sequence of events. The technical fire support rehearsal is conducted to verify the fire support plan and also the communication links for mission execution. The target list, including any refined target locations. The observation plan, including primary and alternate observers, primary and alternate Observation Posts (OPs), the task and purpose of each target, and the engagement criteria for each target are discussed for all fire support events. Priority of fires, by phase of the operation. Priority of targets, ensuring that everyone understands the priority of engaging targets if two targets must be attacked simultaneously. Primary and alternate communications nets, including an anti-jam plan. Fire support coordination measures, ensuring they are de-conflicted. That all unit obstacles are covered by fire.





## Chapter 12

### Terminology

#### Four Forms of Reconnaissance

The four forms of reconnaissance are zone, area, route, and reconnaissance in force.

The S-3 assigns zone reconnaissance when the enemy situation is vague or when he needs information concerning cross-country trafficability. It is appropriate when previous knowledge of the terrain is limited or when combat operations have altered the terrain. The reconnaissance may be threat-oriented, terrain-oriented, society-oriented, infrastructure-oriented, or a combination. Additionally, the unit commander may focus the reconnaissance effort on a specific force, such as the enemy's reserve.

A terrain-focused zone reconnaissance must include the identification of obstacles, both existing and reinforcing, as well as areas of chemical, biological, radiological, and nuclear (CBRN) contamination.

A single continuous line enclosing the reconnaissance area, such as an objective, defines the "area" for an area reconnaissance. A named area of interest, when focusing on a relatively small area such as a building, bridge, or key piece of terrain, can also define the reconnaissance area. Area reconnaissance enables the unit to conduct decentralized reconnaissance in multiple areas simultaneously.

Route reconnaissance is conducted to determine whether the route is clear of obstacles and/or threat forces and how well or how poorly it will support the planned movement. The route is a prescribed course from a start point to a specific destination (release point). It can be a road or an axis of advance. At the unit level, route reconnaissance is a task often performed during zone or area reconnaissance. If enemy contact is expected, it is normal to assign a unit one major route. If enemy contact is unlikely, it is normal to assign a unit two routes.

The normal conduct of a zone, area, and route reconnaissance with a multidimensional focus includes such factors as society and infrastructure as well as the threat and terrain.

Conduct a reconnaissance in force when the enemy is operating within an area and it is not possible to obtain adequate intelligence by other means. It is an aggressive reconnaissance, conducted as an offensive operation, to answer clearly stated commander's critical information requirements (CCIRs). It differs from other reconnaissance operations because the normal conduct is only to gain information about the enemy and not the terrain. The end state of a reconnaissance in force is to determine enemy weaknesses that higher headquarters can exploit.

## Actions by Friendly Force

**Attack by fire** – A tactical mission task in which a commander uses direct fires, supported by indirect fires, to engage an enemy force without closing with the enemy to destroy, suppress, fix, or deceive that enemy. (FM 3-90-1)

**Breach** – A tactical mission task in which the unit employs all available means to break through or establish a passage through an enemy defense, obstacle, minefield, or fortification. (FM 3-90-1)

**Bypass** – A tactical mission task in which the commander directs his unit to maneuver around an obstacle, position, or enemy force to maintain the momentum of the operation while deliberately avoiding combat with an enemy force. (FM 3-90-1)

**Clear** – 1. A tactical mission task that requires the commander to remove all enemy forces and eliminate organized resistance within an assigned area. (FM 3-90-1) 2. The total elimination or neutralization of an obstacle that is usually performed by follow-on engineers and is not done under fire. (ATTP 3-90.4)

**Control** – A tactical mission task that requires the commander to maintain physical influence over a specified area to prevent its use by an enemy or to create conditions necessary for successful friendly operations. (FM 3-90-1)

**Counterreconnaissance** – A tactical mission task that encompasses all measures taken by a commander to counter enemy reconnaissance and surveillance efforts. (FM 3-90-1)

**Disengage** – A tactical mission task where a commander has his unit break contact with the enemy to allow the conduct of another mission or to avoid decisive engagement. (FM 3-90-1)

**Exfiltrate** – A tactical mission task where a commander removes Soldiers or units from areas under enemy control by stealth, deception, surprise, or clandestine means. (FM 3-90-1)

**Follow and assume** – A tactical mission task in which a second committed force follows a force conducting an offensive task and is prepared to continue the mission if the lead force is fixed, attrited, or unable to continue. (FM 3-90-1)

**Follow and support** – A tactical mission task in which a committed force follows and supports a lead force conducting an offensive task. (FM 3-90-1)

**Occupy** – A tactical mission task that involves a force moving a friendly force into an area so that it can control that area. Both the force's movement to and occupation of the area occur without enemy opposition. (FM 3-90-1)

**Reduce** – 1. A tactical mission task that involves the destruction of an encircled or bypassed enemy force. (FM 3-90-1) 2. A mobility task to create and mark lanes through, over, or around an obstacle to allow the attacking force to accomplish its mission. (ATTP 3-90.4)

**Retain** – A tactical mission task in which the commander ensures that a terrain feature controlled by a friendly force remains free of enemy occupation or use. (FM 3-90-1)

**Secure** – A tactical mission task that involves preventing a unit, facility, or geographical location from being damaged or destroyed as a result of enemy action. (FM 3-90-1)

**Seize** – A tactical mission task that involves taking possession of a designated area using overwhelming force. (FM 3-90-1)

**Support by fire** – A tactical mission task in which a maneuver force moves to a position where it can engage the enemy by direct fire in support of another maneuvering force. (FM 3-90-1)

## Effects on Enemy Forces

**Block** – A tactical mission task that denies the enemy access to an area or prevents his advance in a direction or along an avenue of approach. Block is also an obstacle effect that integrates fire planning and obstacle effort to achieve the tactical task. (FM 3-90-1)

**Canalize** – A tactical mission task in which the commander restricts enemy movement to a narrow zone by exploiting terrain coupled with the use of obstacles, fires, or friendly maneuver. (FM 3-90-1)

**Contain** – A tactical mission task that requires the commander to stop, hold, or surround enemy forces or to cause them to center their activity on a given front and prevent them from withdrawing any part of their forces for use elsewhere. (FM 3-90-1)

**Defeat** – A tactical mission task that occurs when an enemy force has temporarily or permanently lost the physical means or the will to fight. The defeated force's commander is unwilling or unable to pursue his adopted course of action, thereby yielding to the friendly commander's will, and can no longer interfere to a significant degree with the actions of friendly forces. Defeat can result from the use of force or the threat of its use. (FM 3-90-1)

**Destroy** – A tactical mission task that physically renders an enemy force combat-ineffective until it is reconstituted. Alternatively, to destroy a combat system is to damage it so badly that it cannot perform any function or be restored to a usable condition without being entirely rebuilt. (FM 3-90-1)

**Disrupt** – 1. A tactical mission task in which a commander integrates direct and indirect fires, terrain, and obstacles to upset an enemy’s formation or tempo, interrupt his timetable, or cause enemy forces to commit prematurely or attack in piecemeal fashion. (FM 3-90-1) 2. An obstacle effect that focuses fire planning and obstacle effort to achieve the tactical task. (FM 90-7)

**Fix** – A tactical mission task where a commander prevents the enemy from moving any part of his force from a specific location for a specific period. Fix is also an obstacle effect that focuses fire planning and obstacle effort to achieve the tactical task. (FM 3-90-1)

**Interdict** – A tactical mission task where the commander prevents, disrupts, or delays the enemy’s use of an area or route. (FM 3-90-1)

**Neutralize** – A tactical mission task that results in rendering enemy personnel or materiel incapable of interfering with a particular operation. (FM 3-90-1)

**Suppress** – A tactical mission task that results in temporary degradation of the performance of a force or weapons system below the level needed to accomplish the mission. (FM 3-90-1)

**Turn** – 1. A tactical mission task that involves forcing an enemy force from one avenue of approach or mobility corridor to another. 2. A tactical obstacle effect that integrates fire planning and obstacle effort to achieve the tactical task. (FM 3-90-1)

## Miscellaneous

**Center of gravity** – The source of power that provides moral or physical strength, freedom of action, or will to act. Also called COG. (JP 5-0)

**Combat power** – The total means of destructive, constructive, and information capabilities that a military unit or formation can apply at a given time. (ADRP 3-0)

**Graphic control measure** – A symbol used on maps and displays to regulate forces and warfighting functions. (ADRP 6-0)

**Intelligence preparation of the battlefield** – A systematic process of analyzing and visualizing the portions of the mission variables of threat, terrain, weather, and civil considerations in a specific area of interest and for a specific mission. By applying intelligence preparation of the battlefield, commanders gain the information necessary to selectively apply and maximize operational effectiveness at critical points in time and space. (ADRP 1-02)

**Mission command** – The exercise of authority and direction by the commander using mission orders to enable disciplined initiative within the commander’s intent to empower agile and adaptive leaders in the conduct of unified land operations. (ADP 6-0)

**Running estimate** – The continuous assessment of the current situation used to determine if the current operation is proceeding according to the commander’s intent and if planned future operations are supportable. (ADP 5-0)

**Situational understanding** – The product of applying analysis and judgment to relevant information to determine the relationship among the operational and mission variables to facilitate decisionmaking. (ADP 5-0)



## Chapter 13

### References

#### Joint Publications

JP 3-0, *Joint Operations*, 11 August 2011

JP 5-0, *Joint Operation Planning*, 11 August 2011

#### U.S. Army Publications

ADP 5-0, *The Operations Process*, May 2012

ADP 6-0, *Mission Command*, May 2012

ADRP 1-02, *Terms and Military Symbols*, September 2013

ADRP 3-0, *Unified Land Operations*, May 2012

ADRP 5-0, *The Operations Process*, May 2012

ADRP 6-0, *Mission Command*, May 2012

ATP 5-19, *Risk Management*, April 2014

FM 3-07, *Stability*, June 2014

FM 3-24, *Insurgencies and Countering Insurgencies*, May 2014

FM 3-55, *Information Collection*, May 2013

FM 3-90-1, *Offense and Defense*, Volume I, March 2013

FM 6-0, *Commander and Staff Organization and Operations*, May 2014





**PROVIDE US YOUR INPUT**

To help you access information quickly and efficiently, the Center for Army Lessons Learned (CALL) posts all publications, along with numerous other useful products, on the CALL website (CAC login required). The CALL website is restricted to U.S. government and allied personnel.

**PROVIDE FEEDBACK OR REQUEST INFORMATION**

<https://call2.army.mil>

If you have any comments, suggestions, or requests for information (RFIs), use the following links on the CALL restricted website (CAC login required): “RFI or Request Pubs” or “Contact CALL.”

**PROVIDE LESSONS AND BEST PRACTICES OR  
SUBMIT AN AFTER ACTION REVIEW (AAR)**

If your unit has identified lessons or best practices or would like to submit an AAR, please contact CALL using the following information:

**Telephone:** DSN 552-9569/9533; Commercial 913-684-9569/9533

**Fax:** DSN 552-4387; Commercial 913-684-4387

**CALL Restricted Website** <<https://call2.army.mil>> (CAC login required):

- Select “Submit Observations, Best Practices, or AARs” tab at the top of the page.
- Under “Document Identification,” enter AAR subject in “Subject of Lesson or TTP” block.
- Identify whether or not the AAR is classified in the “Is it Classified?” block.
- Select the “Browse” button by “File to Upload” block and upload the AAR file.
- Enter questions or comments in the “Comments/Questions” block.
- Press “Submit Form” button.

**Mailing Address:** Center for Army Lessons Learned  
ATTN: Chief, Collection Division  
10 Meade Ave., Bldg. 50  
Fort Leavenworth, KS 66027-1350

**TO REQUEST COPIES OF THIS PUBLICATION**

If you would like copies of this publication, please submit your request at <<https://call2.army.mil>>. Mouse over the “RFI or Request Pubs” tab and select “Request for Publication.” Please fill in all the information, including your unit name and street address. Please include building number and street for military posts.

## CENTER FOR ARMY LESSONS LEARNED

---

**NOTE:** Some CALL publications are no longer available in print. Digital publications are available by using the “Products” tab on the CALL restricted website.

### PRODUCTS AVAILABLE ONLINE

#### CENTER FOR ARMY LESSONS LEARNED

Access and download information from CALL’s restricted website. CALL also offers Web-based access to the CALL archives. The CALL restricted website address is:

**<https://call2.army.mil>**

CALL produces the following publications on a variety of subjects:

- **Handbooks**
- **Bulletins, Newsletters, and Trends Reports**
- **Special Studies**
- *News From the Front*
- **Training Lessons and Best Practices**
- **Initial Impressions Reports**

You may request these publications by using the “RFI or Request Pubs” tab on the CALL restricted website. (**NOTE:** Some CALL publications are no longer available in print. Digital publications are available by using the “Products” tab on the CALL restricted website.)

#### COMBINED ARMS CENTER (CAC) Additional Publications and Resources

The CAC home page address is:

**<http://usacac.army.mil>**

#### **Center for Army Leadership (CAL)**

CAL plans and programs leadership instruction, doctrine, and research. CAL integrates and synchronizes the Professional Military Education Systems and Civilian Education System. Find CAL products at <<http://usacac.army.mil/cac2/cal>>.

#### **Combat Studies Institute (CSI)**

CSI is a military history think tank that produces timely and relevant military history and contemporary operational history. Find CSI products at <<http://usacac.army.mil/cac2/csi/csipubs.asp>>.

#### **Combined Arms Doctrine Directorate (CADD)**

CADD develops, writes, and updates Army doctrine at the corps and division level. Find the doctrinal publications at either the Army Publishing Directorate (APD) <<http://www.apd.army.mil>> or the Central Army Registry (formerly known as the Reimer Digital Library) <<http://www.adtdl.army.mil>>.

### **Foreign Military Studies Office (FMSO)**

FMSO is a research and analysis center on Fort Leavenworth under the TRADOC G2. FMSO manages and conducts analytical programs focused on emerging and asymmetric threats, regional military and security developments, and other issues that define evolving operational environments around the world. Find FMSO products at <http://fmso.leavenworth.army.mil>.

### **Military Review (MR)**

MR is a revered journal that provides a forum for original thought and debate on the art and science of land warfare and other issues of current interest to the U.S. Army and the Department of Defense. Find MR at <http://usacac.army.mil/cac2/militaryreview>.

### **TRADOC Intelligence Support Activity (TRISA)**

TRISA is a field agency of the TRADOC G2 and a tenant organization on Fort Leavenworth. TRISA is responsible for the development of intelligence products to support the policy-making, training, combat development, models, and simulations arenas. Find TRISA at <https://atn.army.mil/media/dat/TRISA/trisa.aspx> (CAC login required).

### **Combined Arms Center-Capability Development Integration Directorate (CAC-CDID)**

CAC-CDIC is responsible for executing the capability development for a number of CAC proponent areas, such as Information Operations, Electronic Warfare, and Computer Network Operations, among others. CAC-CDID also teaches the Functional Area 30 (Information Operations) qualification course. Find CAC-CDID at <http://usacac.army.mil/cac2/cdid>.

### **Joint Center for International Security Force Assistance (JCISFA)**

JCISFA's mission is to capture and analyze security force assistance (SFA) lessons from contemporary operations to advise combatant commands and military departments on appropriate doctrine; practices; and proven tactics, techniques, and procedures (TTP) to prepare for and conduct SFA missions efficiently. JCISFA was created to institutionalize SFA across DOD and serve as the DOD SFA Center of Excellence. Find JCISFA at <https://jcisfa.jcs.mil/Public/Index.aspx>.

*Support CAC in the exchange of information by telling us about your successes so they may be shared and become Army successes.*





# Center for Army Lessons Learned

10 Meade Avenue, Building 50  
Fort Leavenworth, KS 66027-1350



[www.leavenworth.army.mil](http://www.leavenworth.army.mil)

Approved for Public Release  
Distribution Unlimited



US Army  
Combined  
Arms Center

"Intellectual Center of the Army"