

Chapter 10

Section A

Enlisted Career Progression Charts

10-1-1. General

This chapter contains career progression charts for each enlisted career management field (CMF) and approved for enlisted classification.

10-1-2. Specifications for Enlisted Career Progression Charts

This chapter contains career progression charts for each enlisted specialty. The chapter is organized by each CMF and defined as CMF XX where XX represents the enlisted CMF. For example the specifications for CMF13, Field Artillery are located in section CMF 13.

CMF DEFINITION
00 IMMATERIAL
09 PERSONNEL SPECIAL REPORTING CODES
11 INFANTRY
12 ENGINEER
13 FIELD ARTILLERY
14 AIR DEFENSE ARTILLERY
15 AVIATION
17 CYBER
18 SPECIAL FORCES
19 ARMOR
25 COMMUNICATIONS AND INFORMATION SYSTEMS OPERATION
27 PARALEGAL
29 ELECTRONIC WARFARE
31 MILITARY POLICE
35 MILITARY INTELLIGENCE
36 FINANCIAL MANAGEMENT
37 PSYCHOLOGICAL OPERATIONS
38 CIVIL AFFAIRS
42 ADJUTANT GENERAL
46 PUBLIC AFFAIRS
51 ACQUISITION, LOGISTICS & TECHNOLOGY
56 RELIGIOUS SUPPORT
68 MEDICAL
74 CHEMICAL, BIOLOGICAL RADIOLOGICAL AND NUCLEAR (CBRN)
79 RECRUITMENT AND REENLISTMENT
88 TRANSPORTATION
89 AMMUNITION
91 MECHANICAL MAINTENANCE
92 SUPPLY AND SERVICES
94 ELECTRONIC MAINTENANCE AND CALIBRATIONS

**Table 10-1-1
MOS Substitution**

CMF	Substituting MOS	Substituted MOS
11	11C	11B
12	None	
13	None	
14	None	
15	None	
17	25B,35Q,35V,35Z	17C (Expires 20211001 NOFC E-1510-08/E-1710-21)
18	None	
19	None	
25	25C	25U (10Jun20-30Sep21) (NOFC A-2010-13)
25	25U	25C (10Jun20-30Sep21) (NOFC A-2010-13)
27	None	
29	None	
31	None	
35	None	
36	None	
37	None	
38	Any; Must be E-5 with 5 Yrs Service	38
42	None	
46	46V1O (Eff 202210)	46S1O
51	None	
56	None	
68	68	Any CMF 68 MOS can serve as First Sgt, Operations, Intel/plans, Tng, IG, EOA, or Det Sgt at the MSG and SFC levels
74	None	
79	None	
88	None	
89	89A and 89B	At skill level 1 only and if 89B previously performed Ammunition Stock Control & Accounting Specialist duties prior to Oct 2007

91	91F	91K
92	92A5M	92Y5M
92	92Y5M	92A5M
94	None	

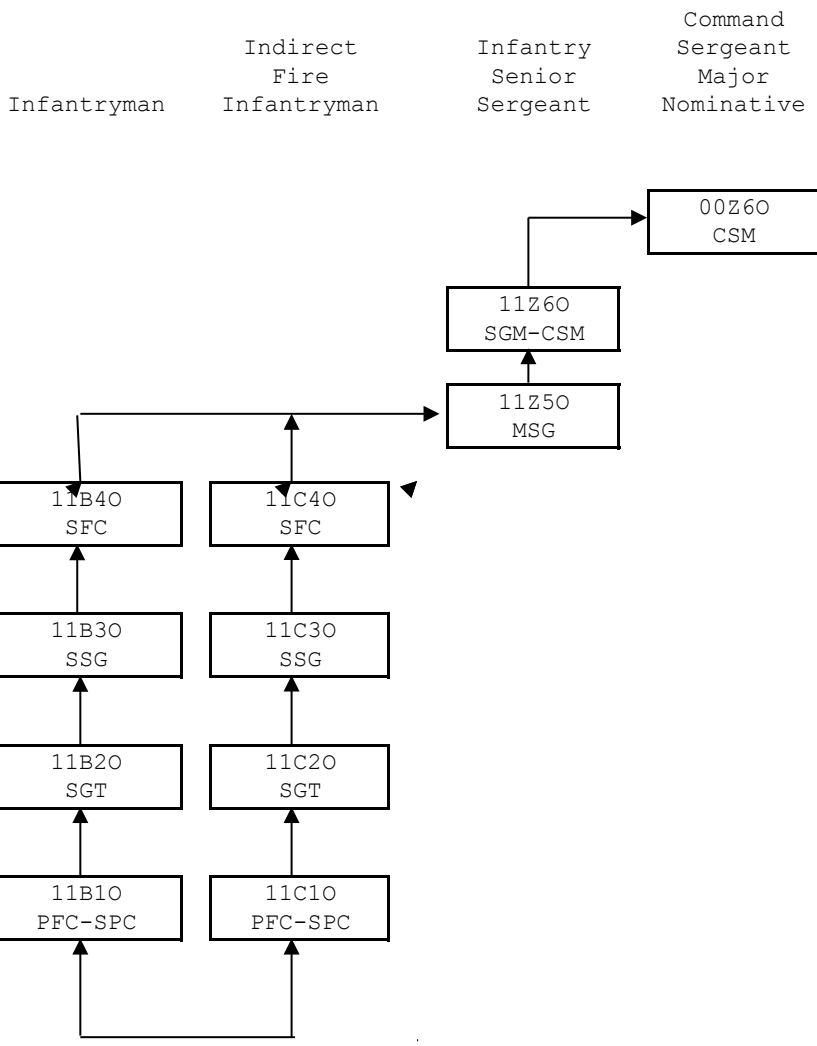

SUBSTITUTABILITY: 11C for 11B ◀

Figure 10-11. CMF 11 - Infantry career progression (Effective 1110)

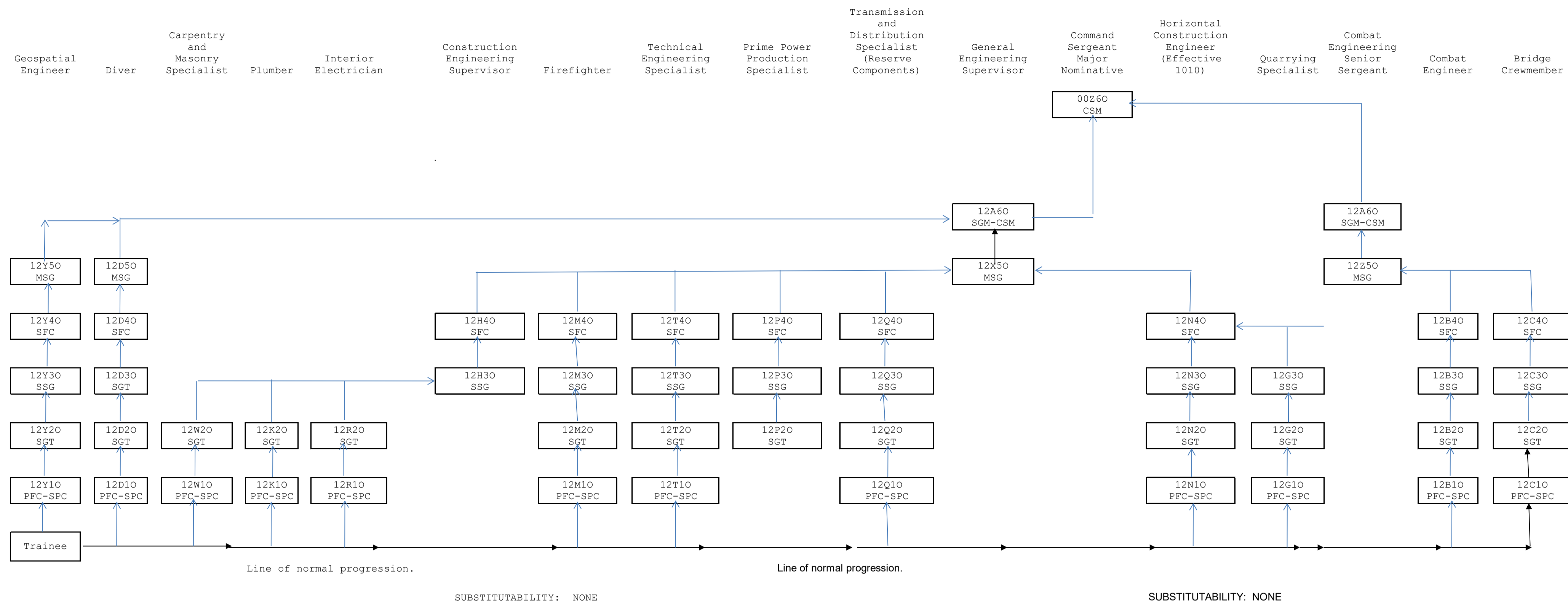

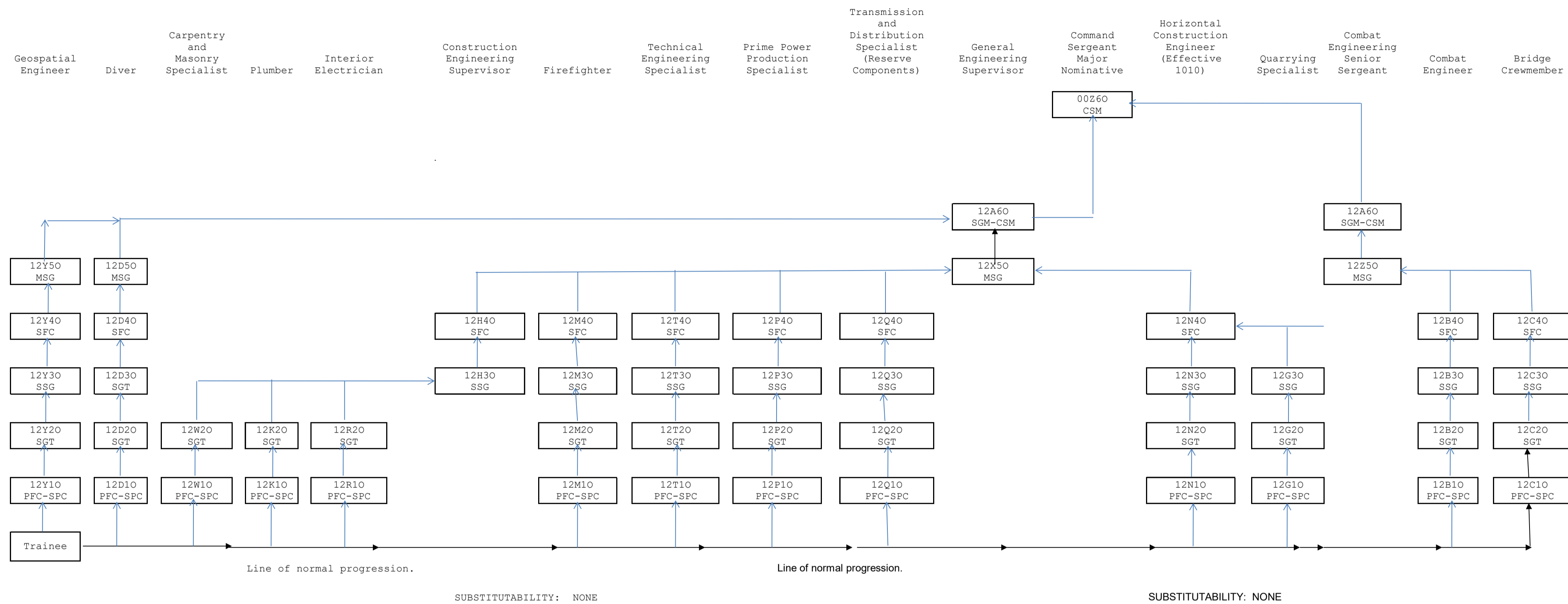

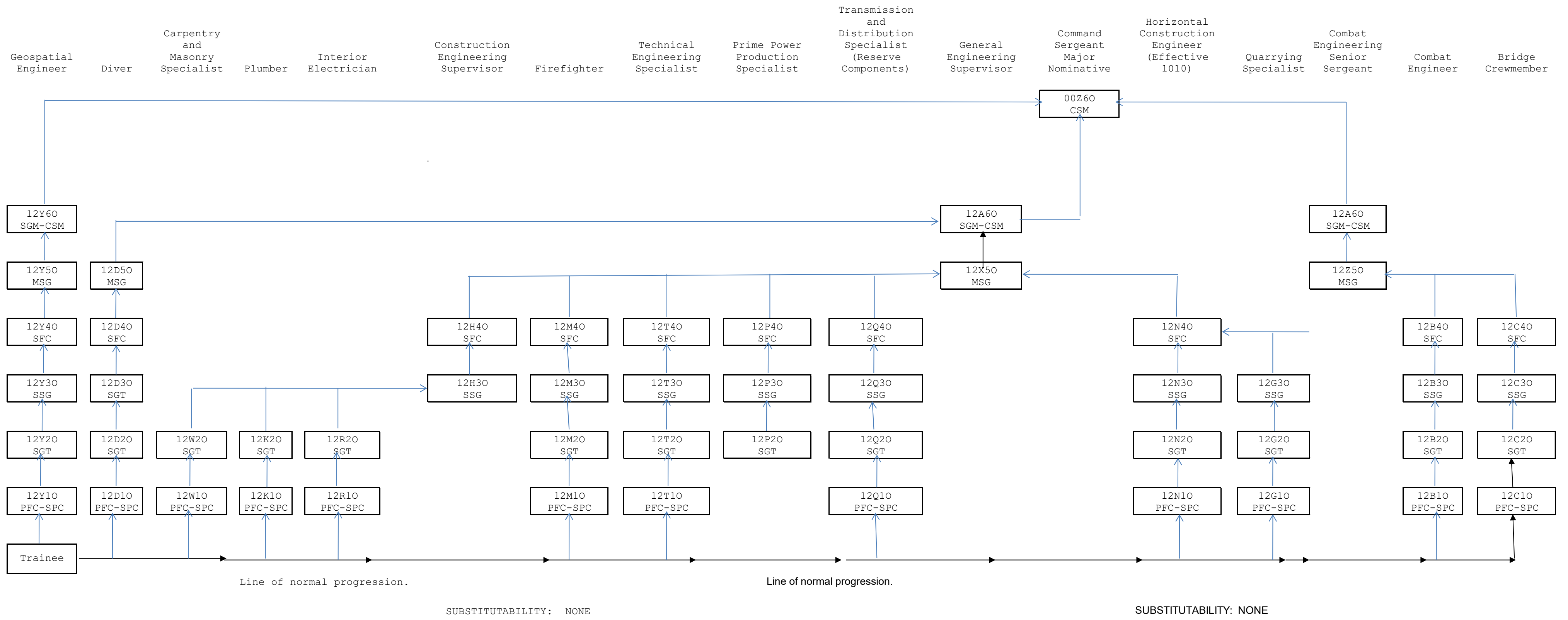

Figure 10-21a. CMF 12 - Engineer career

Figure 10-21b. CMF 12 - Engineer career progression (Effective 20191)

Figure 10-21c. CMF 12 - Engineer career progression (Effective 201910)

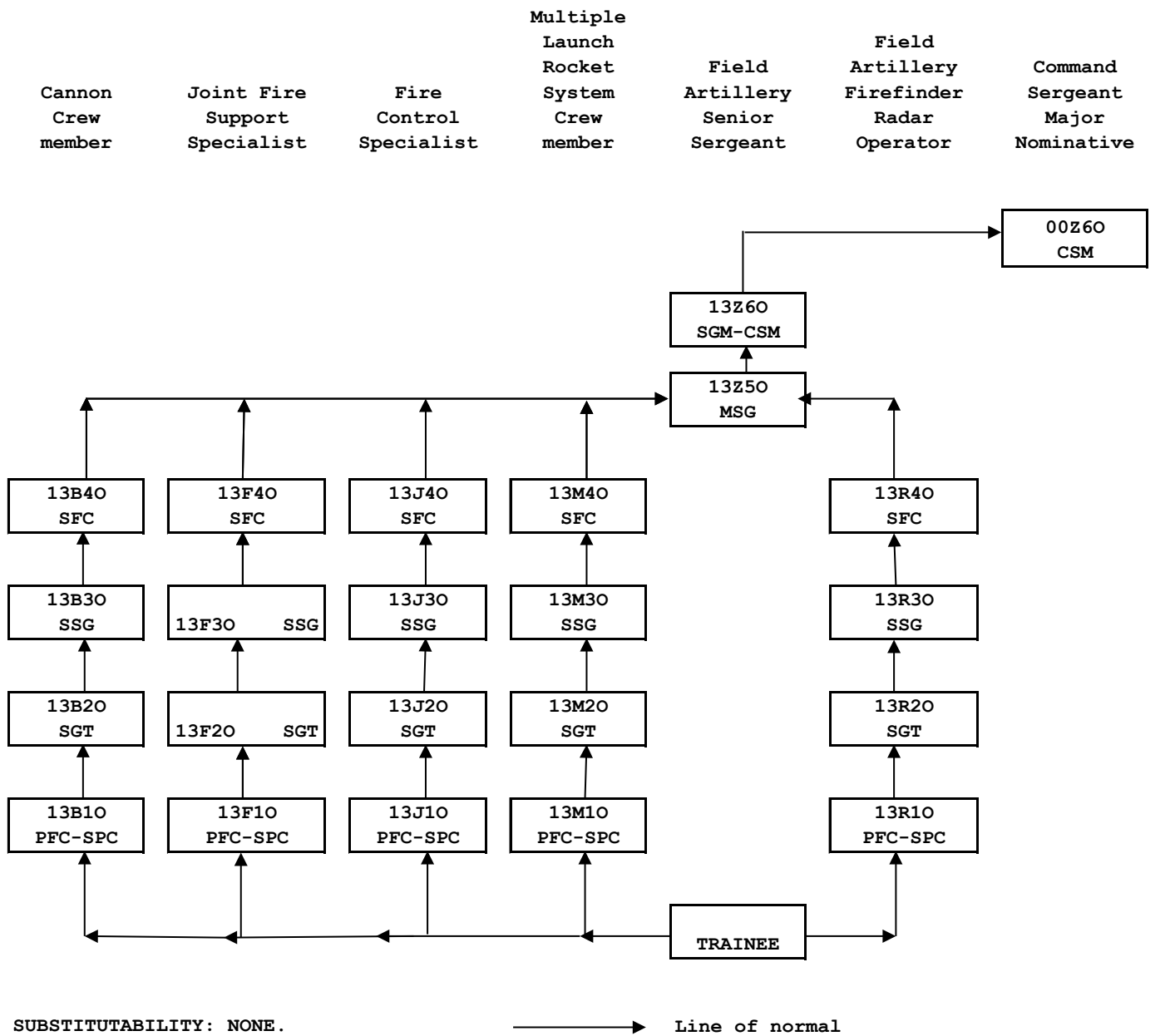

Figure 10-13a. CMF 13 - Field Artillery career progression (Effective 201710)

Cannon
Crew
member

Joint
Fire
Support
Speciali
st

Fire
Control
Speciali
st

Multiple
Launch
Rocket
System
Crew
member

Joint
Fire
Support
Speciali
st

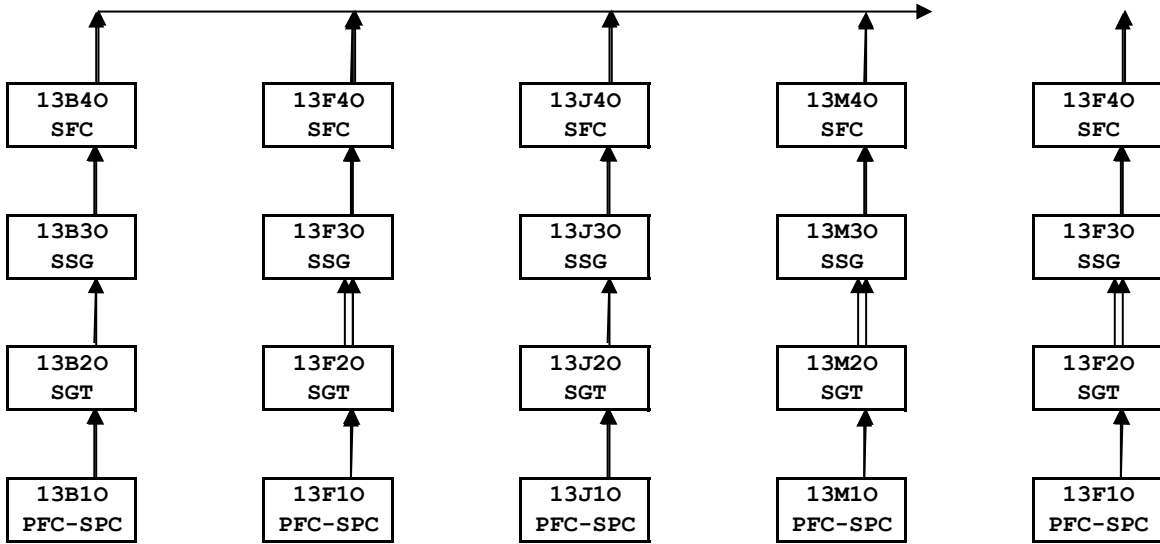

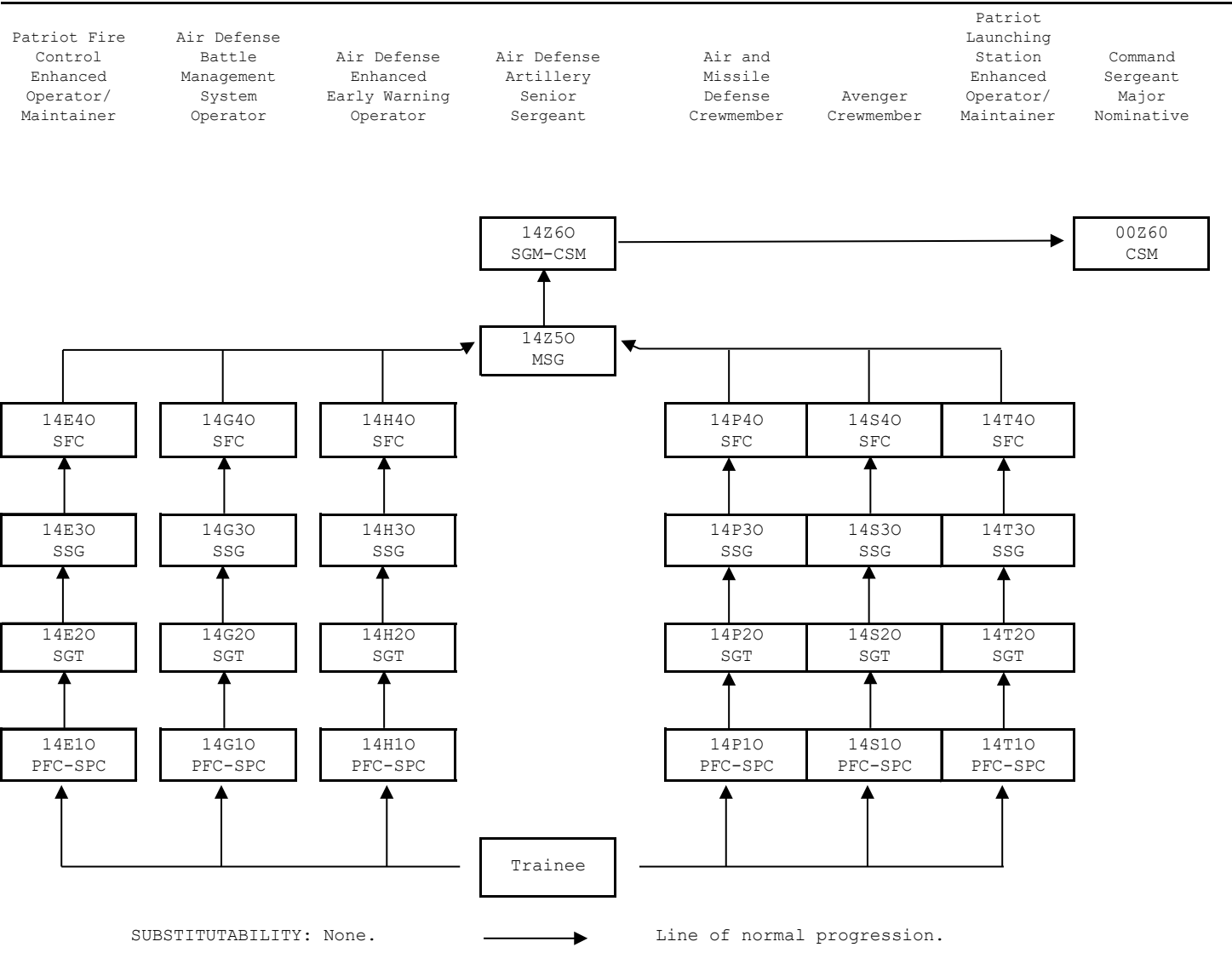

Figure 10-14. CMF 14 - Air Defense Artillery career progression (Effective 201610)

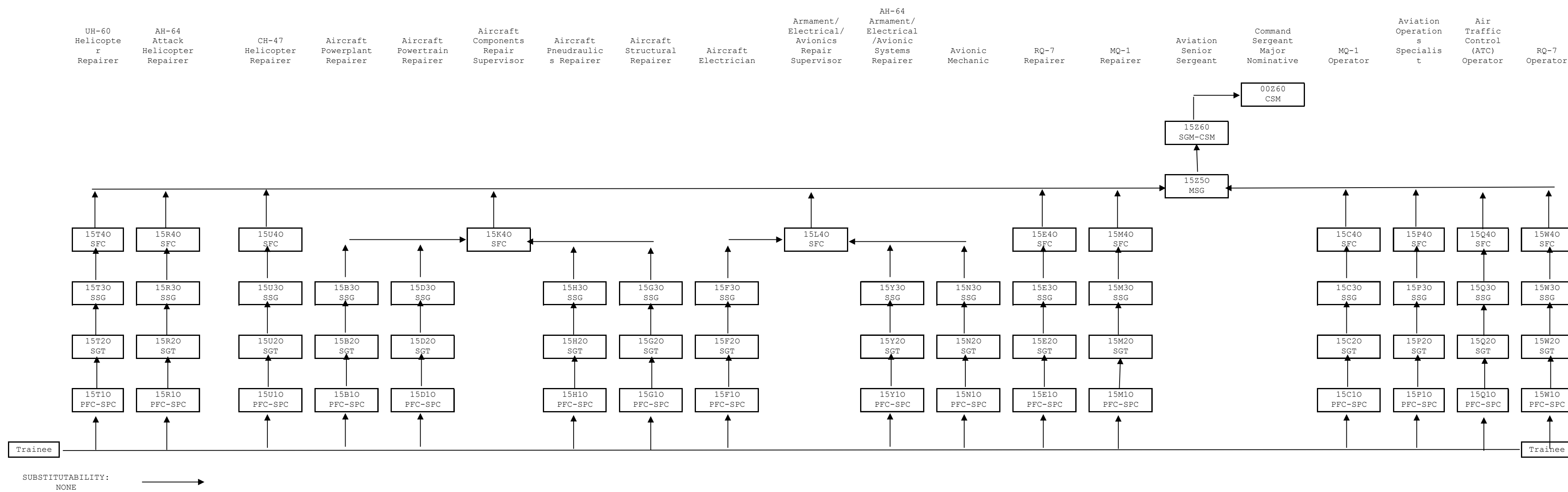
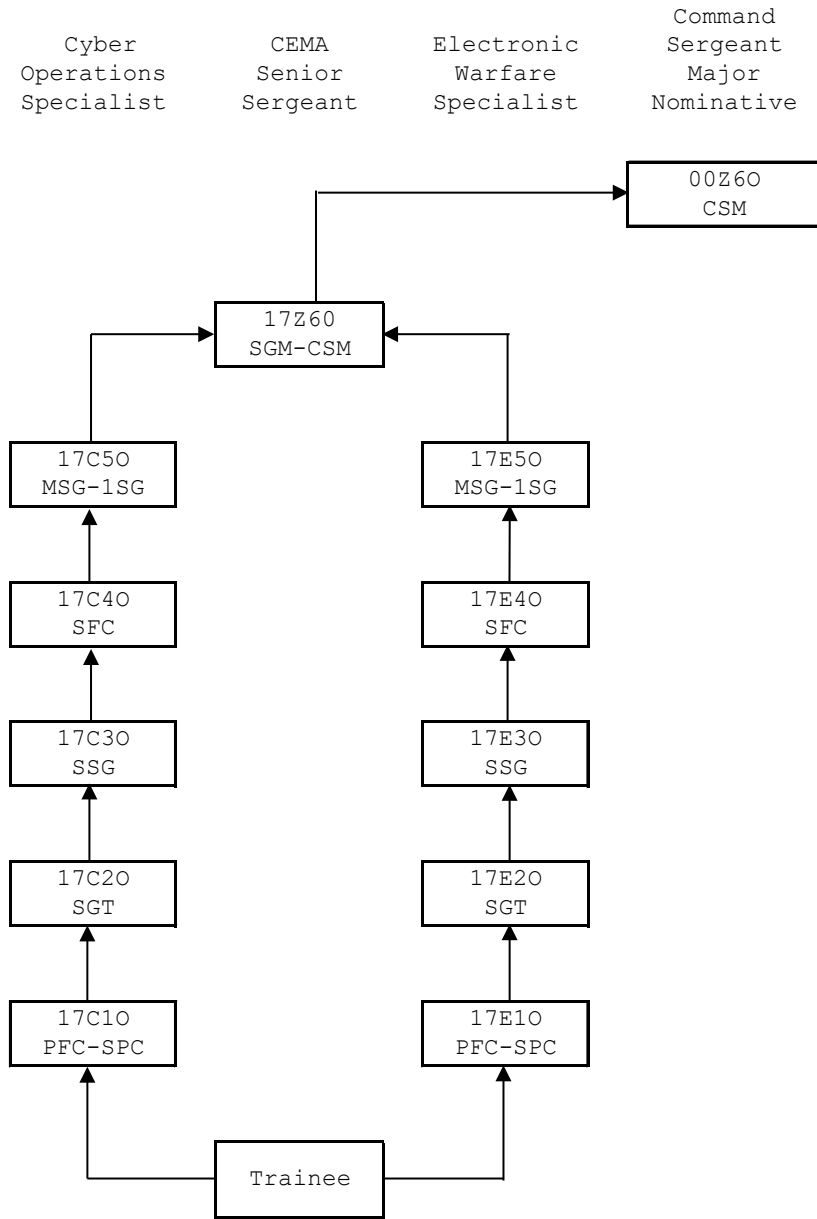
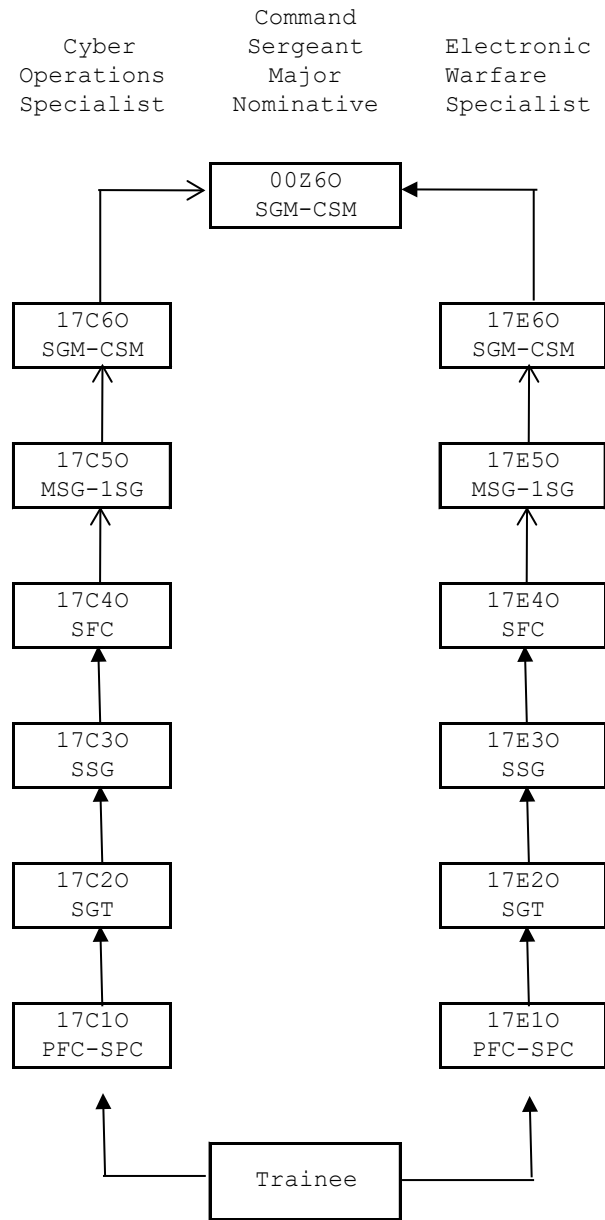

Figure 10-15 CMF 15 - Aviation career progression Effective 202110



SUBSTITUTABILITY FOR 17C: 25B, and 35Z

Figure 10-17. CMF 17 Cyber Career Progression (Effective 202210)



SUBSTITUTABILITY FOR 17C: 25B, 35Q, 35V, and 35Z

Figure 10-17. CMF 17 Cyber Operations Specialist/Electronic Warfare Specialist Career Progression (Effective 201812)

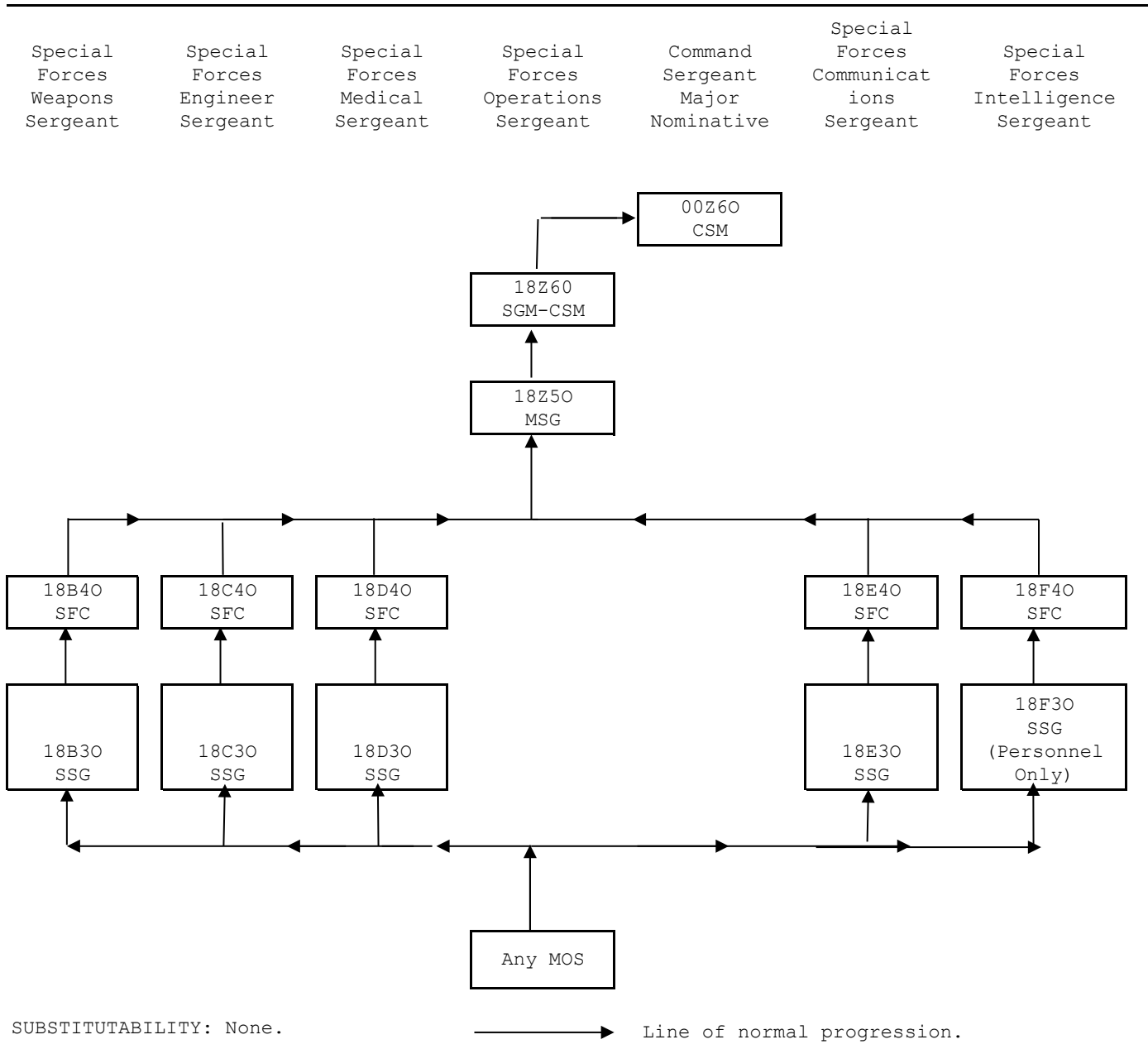

Figure 10-18. CMF 18-Special Forces career progression (Effective 202208)

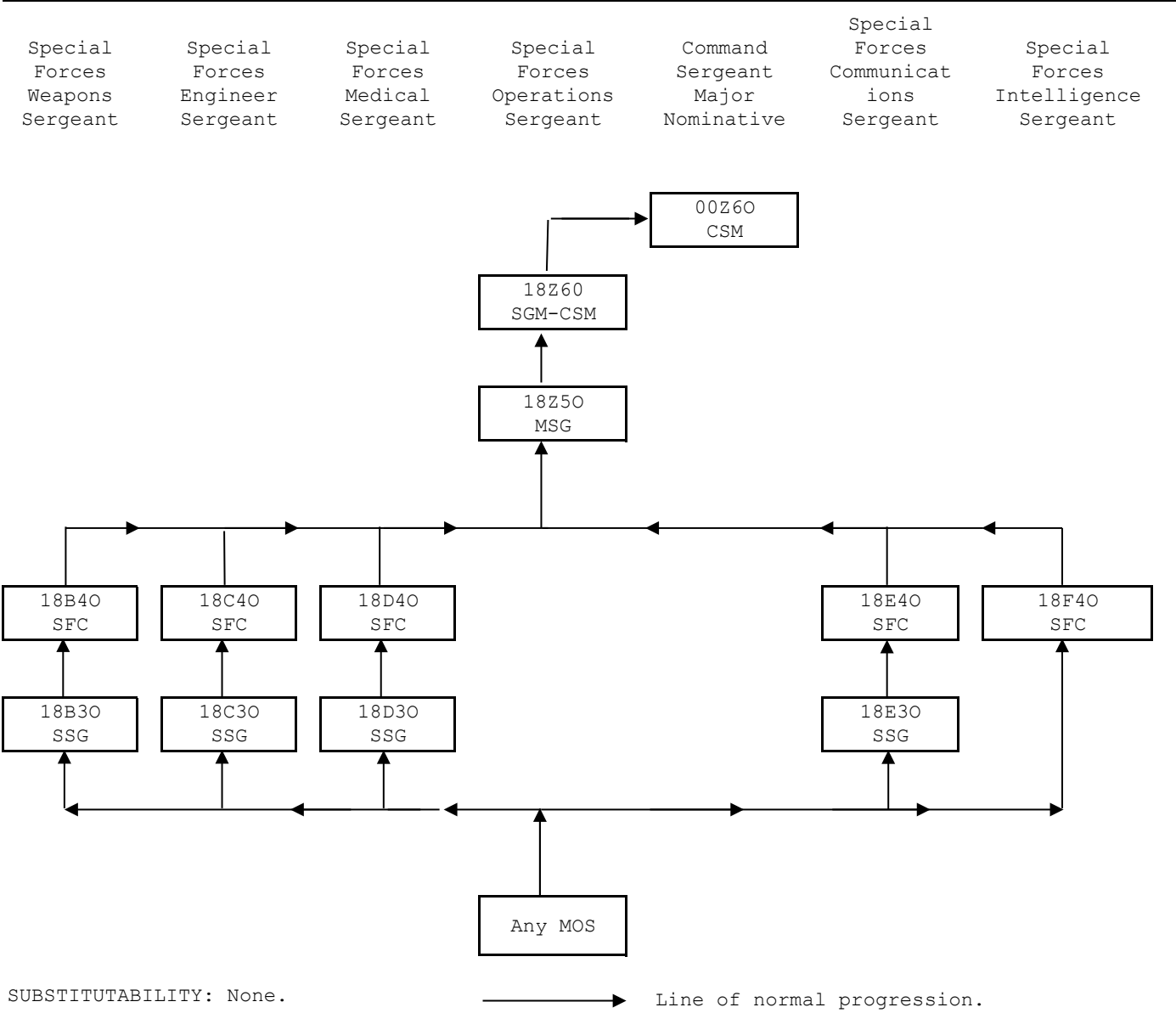
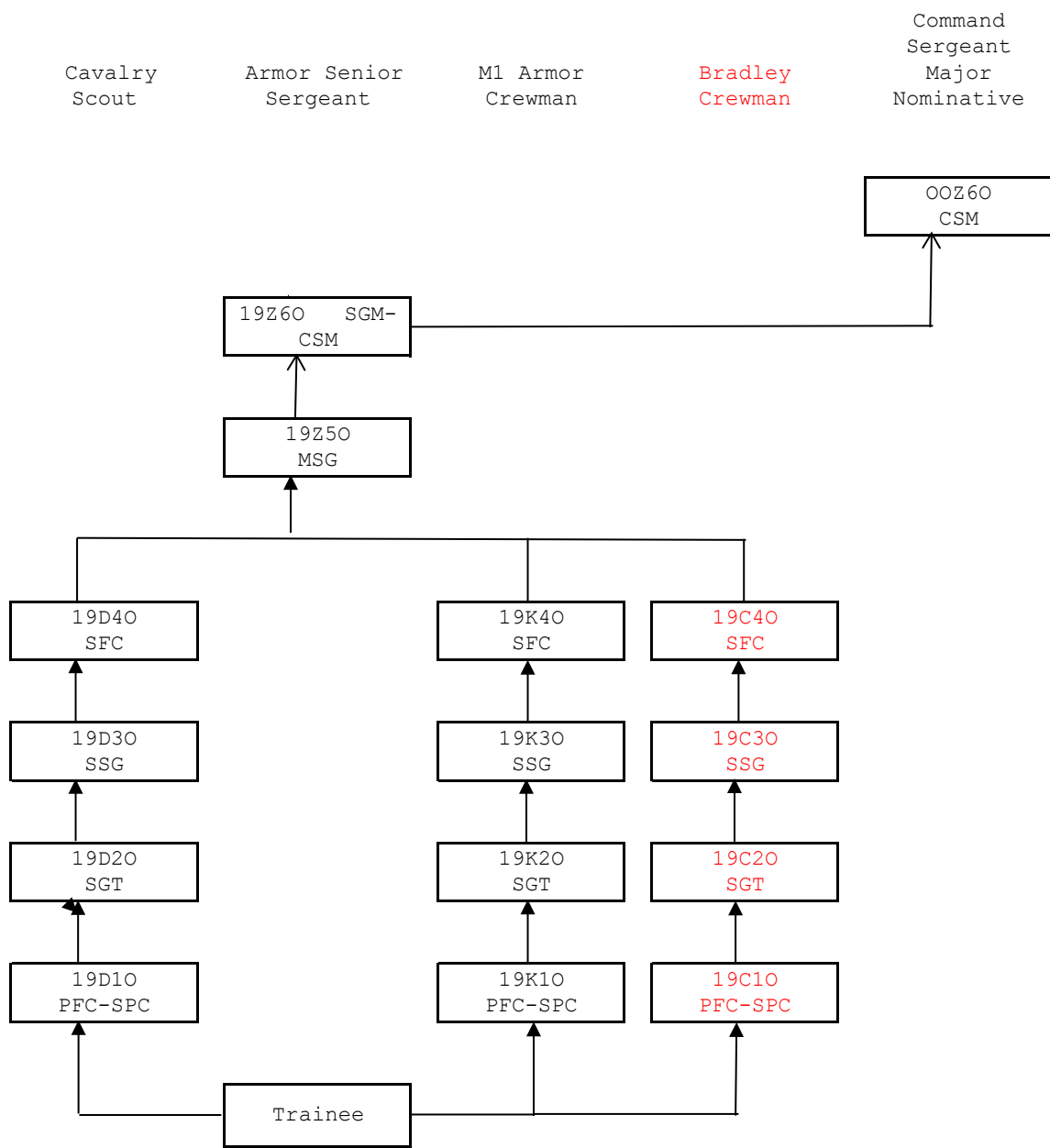

Figure 10-18. CMF 18-Special Forces career progression (Effective 201110)



SUBSTITUTABILITY: None.

→ Line of normal progression.

Figure 10-19. CMF 19 - Armor career progression (Effective 202410)

Cavalry Scout	Armor Senior Sergeant	M1 Armor Crewman	Command Sergeant Major Nominative
------------------	-----------------------------	---------------------	--

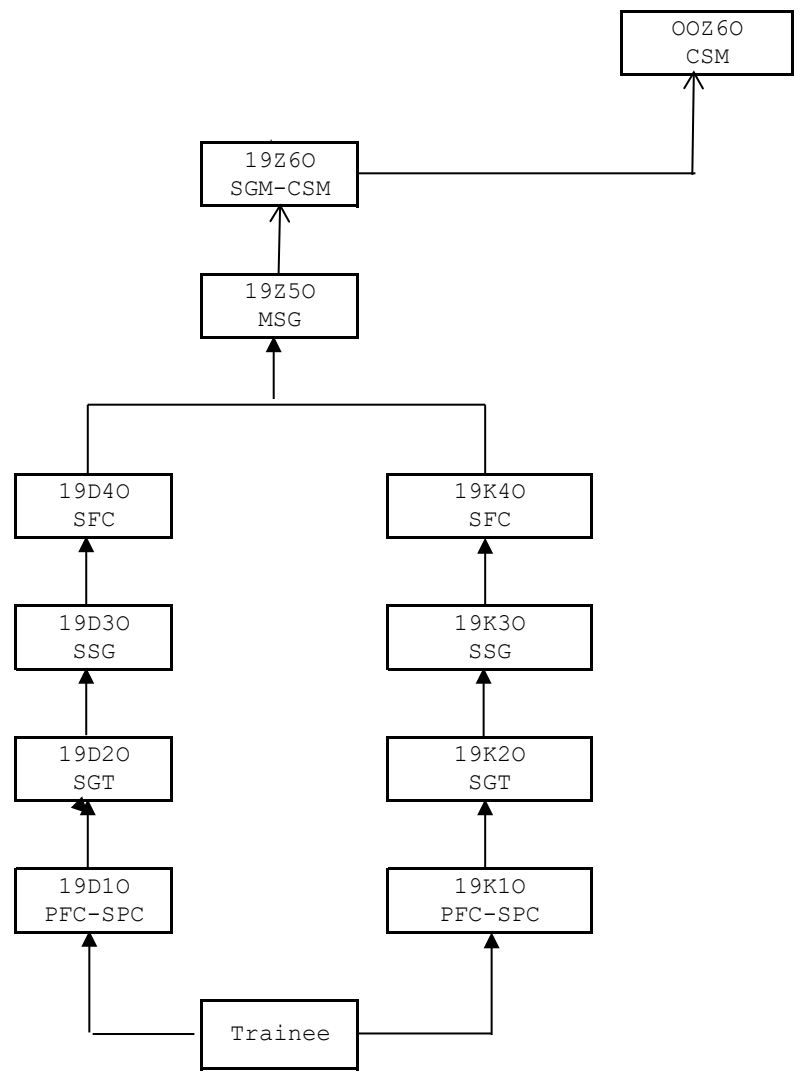

SUBSTITUTABILITY: None.

—————> Line of normal progression.

Figure 10-19. CMF 19 - Armor career progression (Effective 1611)

Information Technology Specialist	Command Sergeant Major Nominative	Cable Systems Installer- Maintainer	Network Communication Systems Specialist	Chief Signal NCO	Satellite Communicati ons Systems Operator- Maintainer	Signal Operations Support Specialist
---	--	--	---	------------------------	--	---

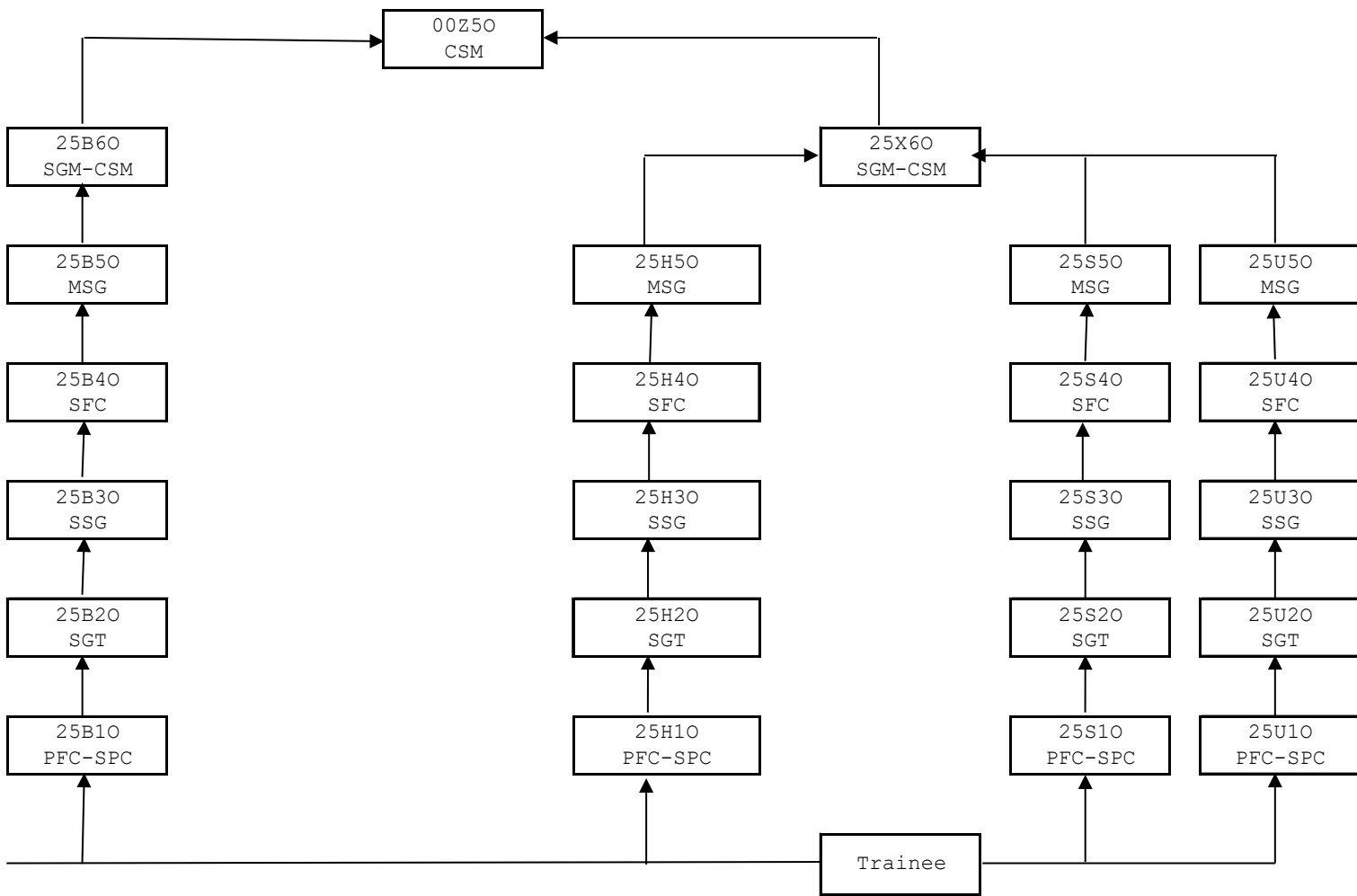

SUBSTITUTABILITY: None

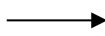

Line of normal progression.

Effective 202210

Figure 10-25a. CMF 25--Communication and Information Systems career pi

Electro-
magnetic
Spectrum
Manager

Cyber
Network
Defender

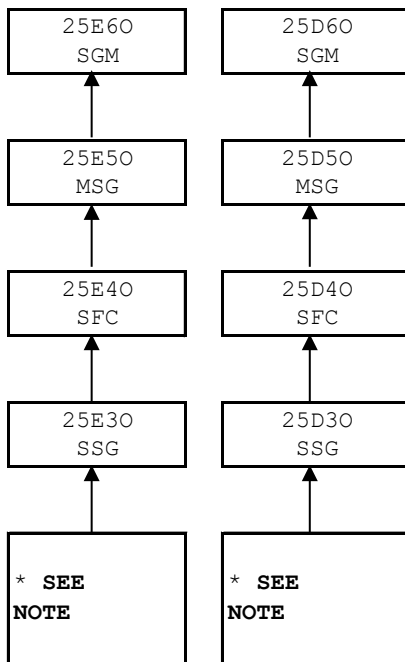

*NOTE: Candidates will be selected from Soldiers in grade SSG in any MOS which has completed their required DLC.

rogression

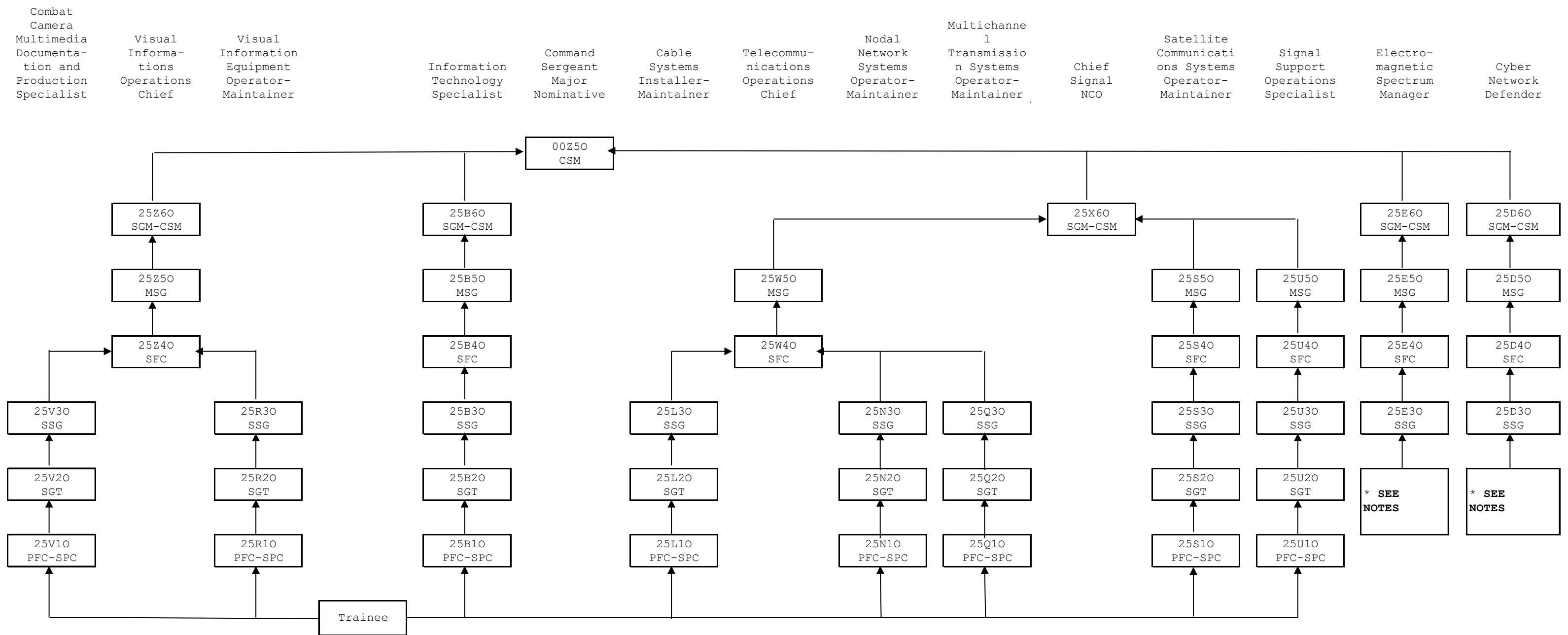

SUBSTITUTABILITY: None

→ Line of normal progression.

*NOTE: Candidates will be selected from Soldiers in grade SSG in any MOS which has completed their respective ALC.

Effective 202110

Figure 10-25a. CMF 25--Communication and Information Systems career progression

Paralegal
Specialist

Command
Sergeant
Major
Nominative

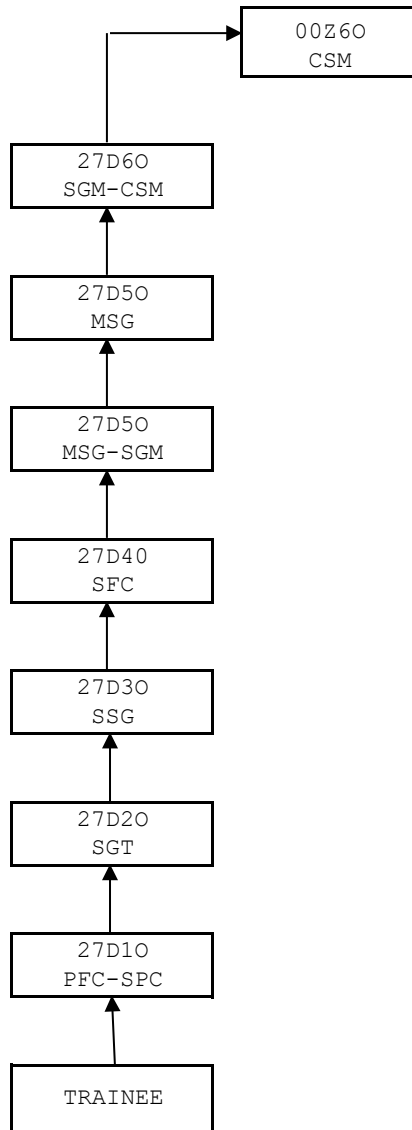

SUBSTITUTABILITY: None.

—————> Line of normal progression.

Figure 10-27. CMF 27--Paralegal career progression. (Effective 201110)

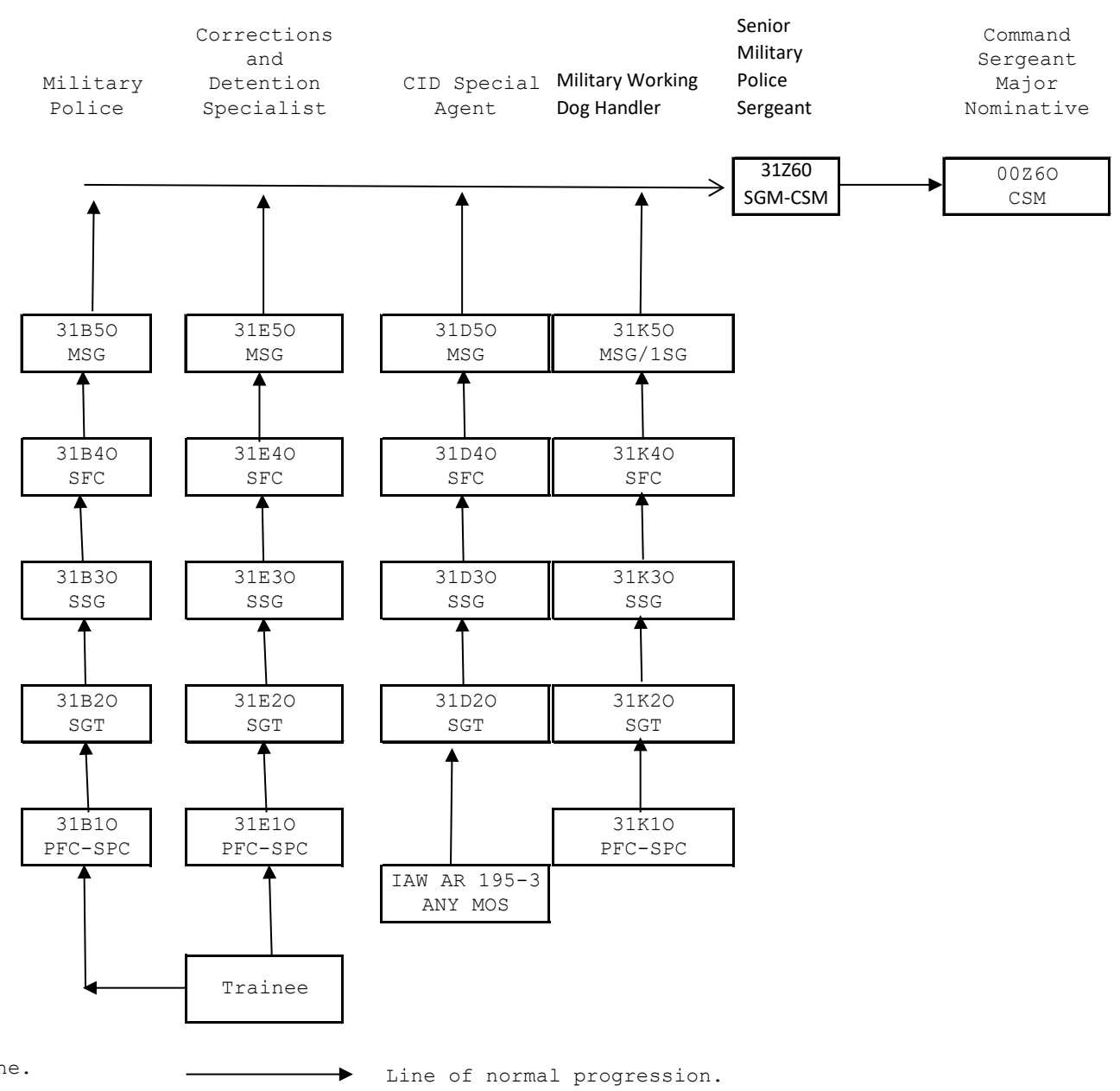
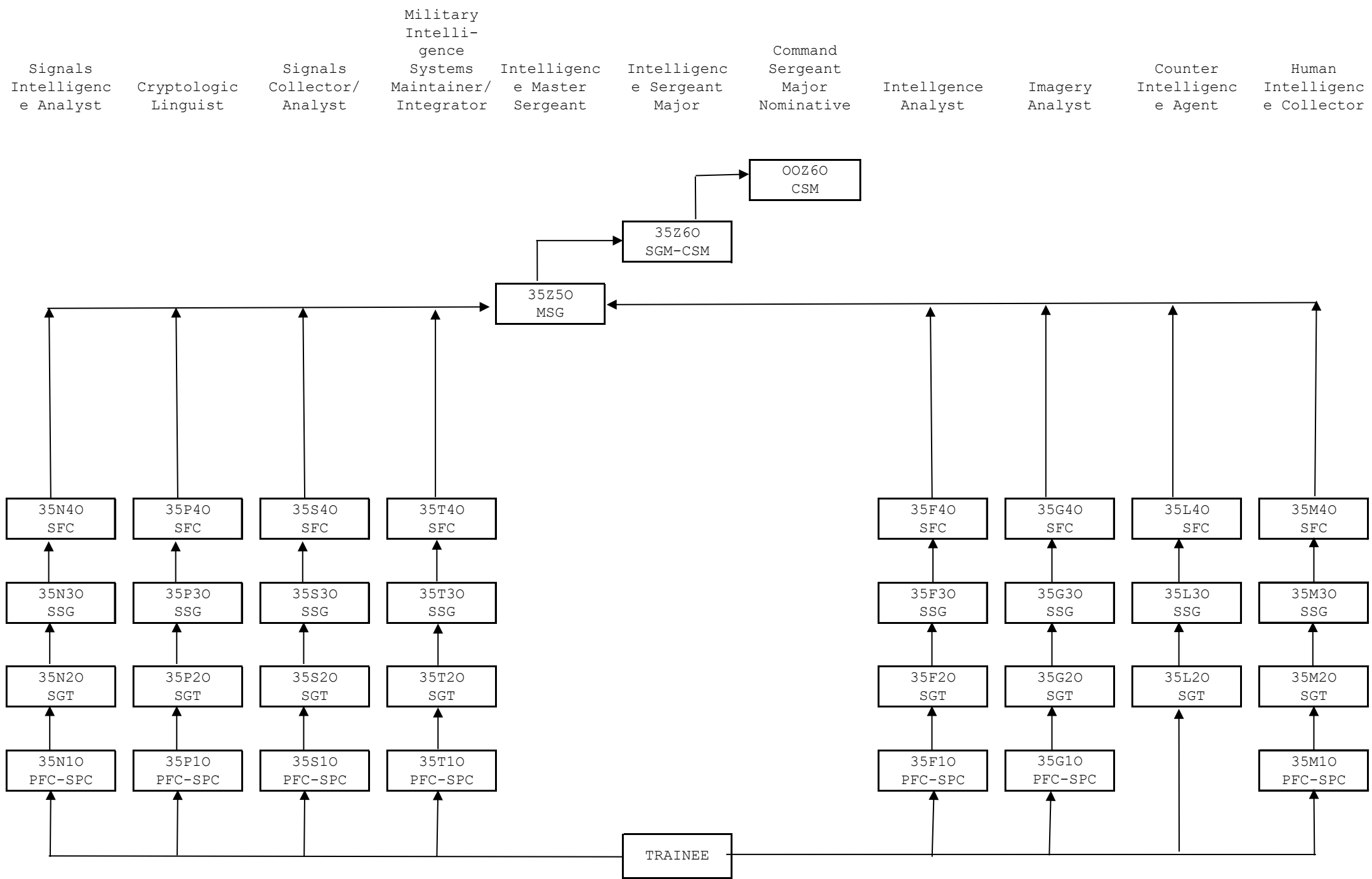

Figure 10-31. CMF 31 - Military Police career progression (Effective 202010)



SUBSTITUTABILITY: None

Line of normal progression.

Figure 10-35. CMF 35 - Military Intelligence career progression (Effective 20201001)

Financial
Management
Technician

Command
Sergeant
Major
Nominative

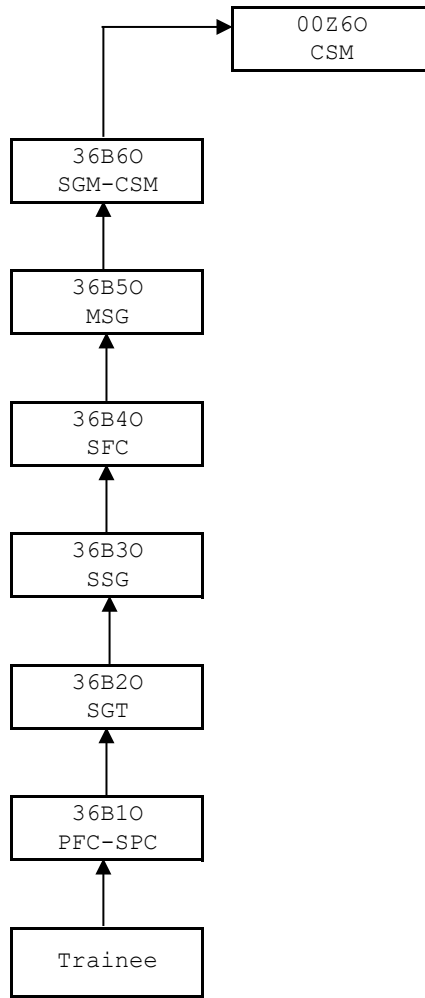

SUBSTITUTABILITY: None.

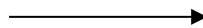

Line of normal progression.

Figure 10-1. CMF 36--Financial management career progression. (Effective 201110)

Psychological
Operations
Specialist

Command
Sergeant
Major
Nominative

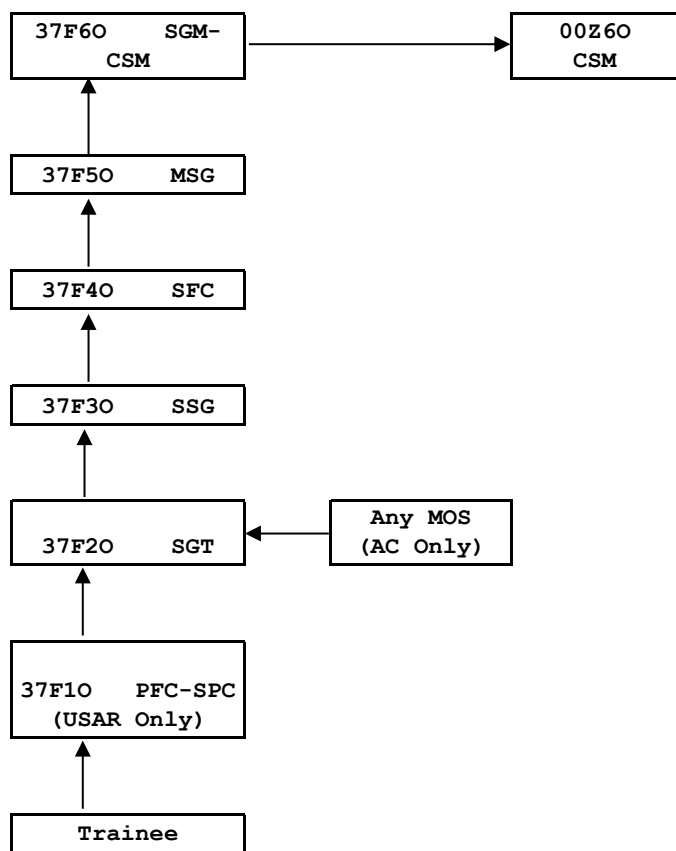

SUBSTITUTABILITY: None.



Line of normal progression.

Figure 10-37. CMF 37 - Psychological Operations Career progression (Effective 201910)

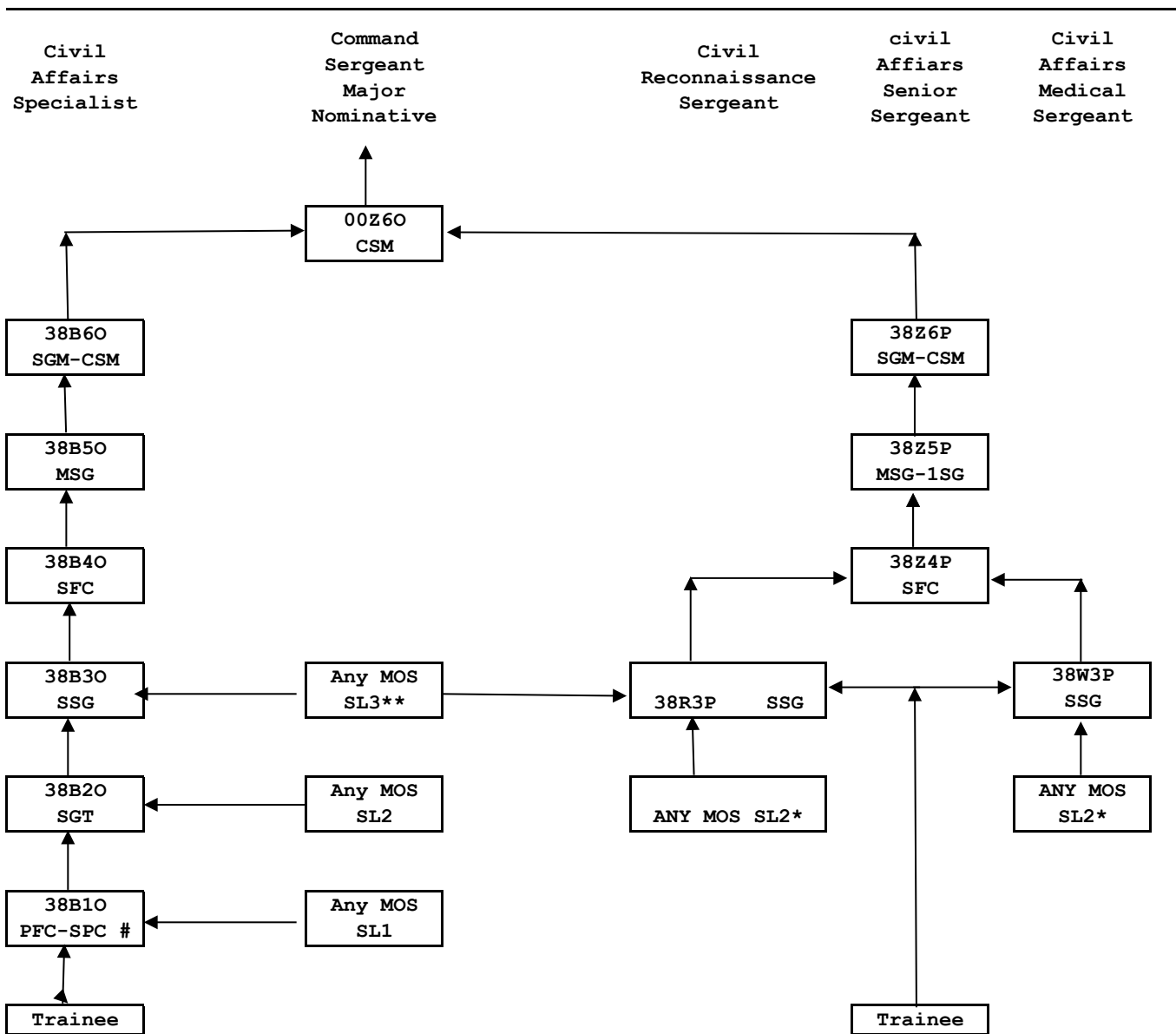

SUBSTITUTABILITY: Any CMF may apply to reclassify into CMF 38.
 * Must be in grade SGT (E-5) with minimum of 5 years of service. **
 By exception Soldiers in grade SSG(P) and SFC, refer to chapter 10, para 10-38B, sub-para b.

—————> Line of normal progression.
 Instruction.

Figure 10-38. CMF 38 - Civil Affairs Specialist career progression (Effective 202310)

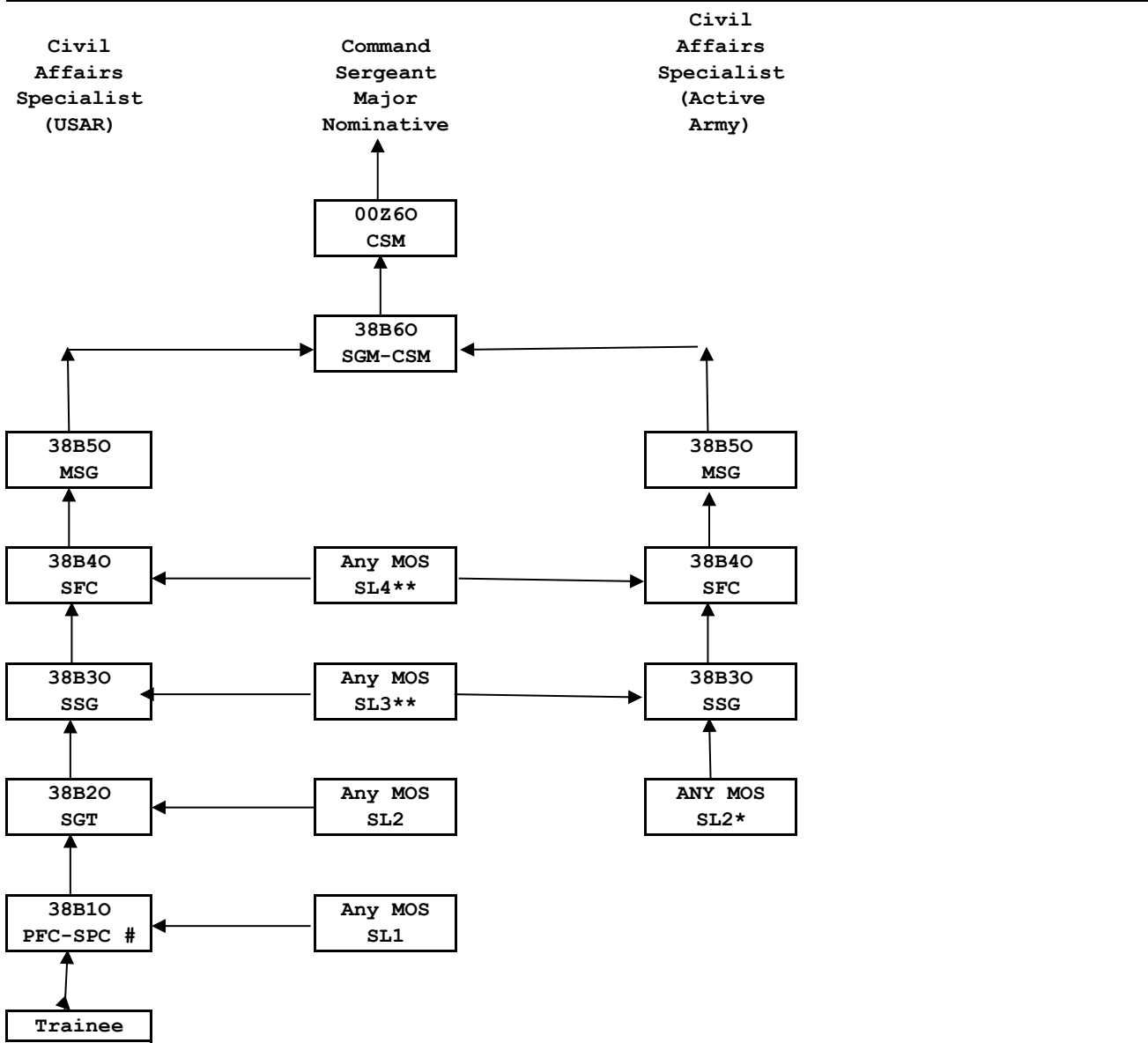

SUBSTITUTABILITY: Any CMF may apply to reclassify into CMF 38.
 * Must be in grade SGT (E-5) with minimum of 5 years of service. **
 By exception Soldiers in grade SSG(P) and SFC, refer to chapter 10, para 10-38B, sub-para b.

—————> Line of normal progression.
 Instruction.

Figure 10-38. CMF 38 - Civil Affairs Specialist career progression (Effective 201110)

Human Resources Specialist Command Sergeant Major Nominative Army Bandsperson Special Band Member

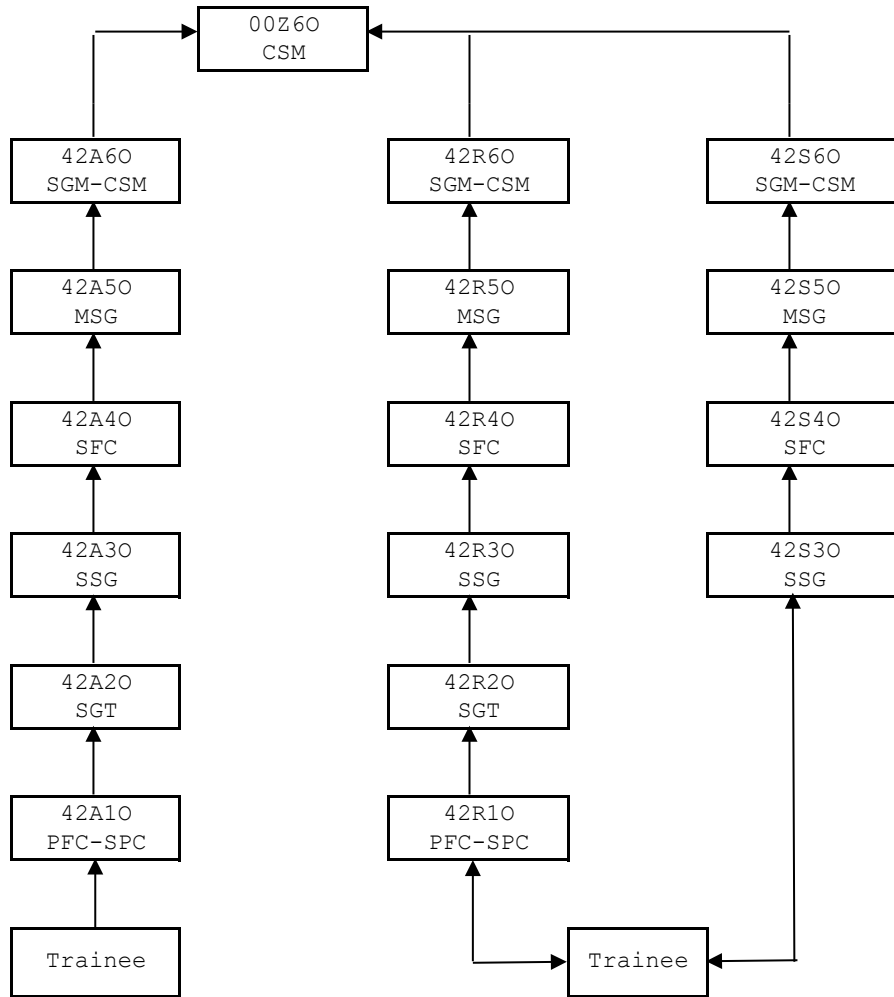

SUBSTITUTABILITY:
None.

—————> Line of normal progression.

Figure 10-1. CMF 42--Adjutant General career progression. (Effective 201110)

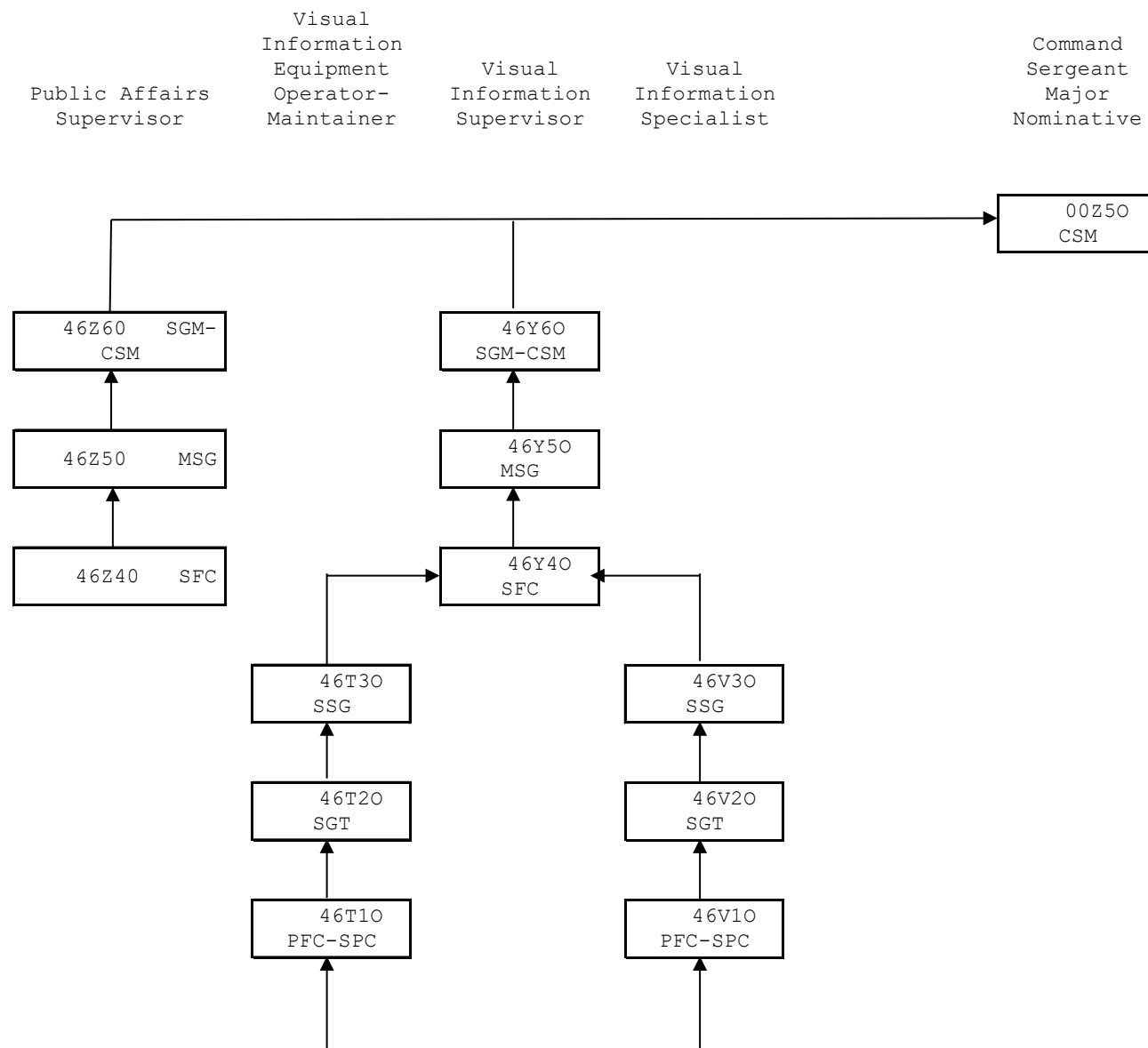

.ITY: 46V10 for
 ;S10

→ Line of normal progression.

Effective 202210

a. CMF 46--Public Affairs and Visual Information career progression

PUBLIC
AFFAIRS MASS
COMM
SPECIALIST

CHIEF PUBLIC
AFFAIRS NCO

COMMAND
SERGEANT MAJOR
NOMINATIVE

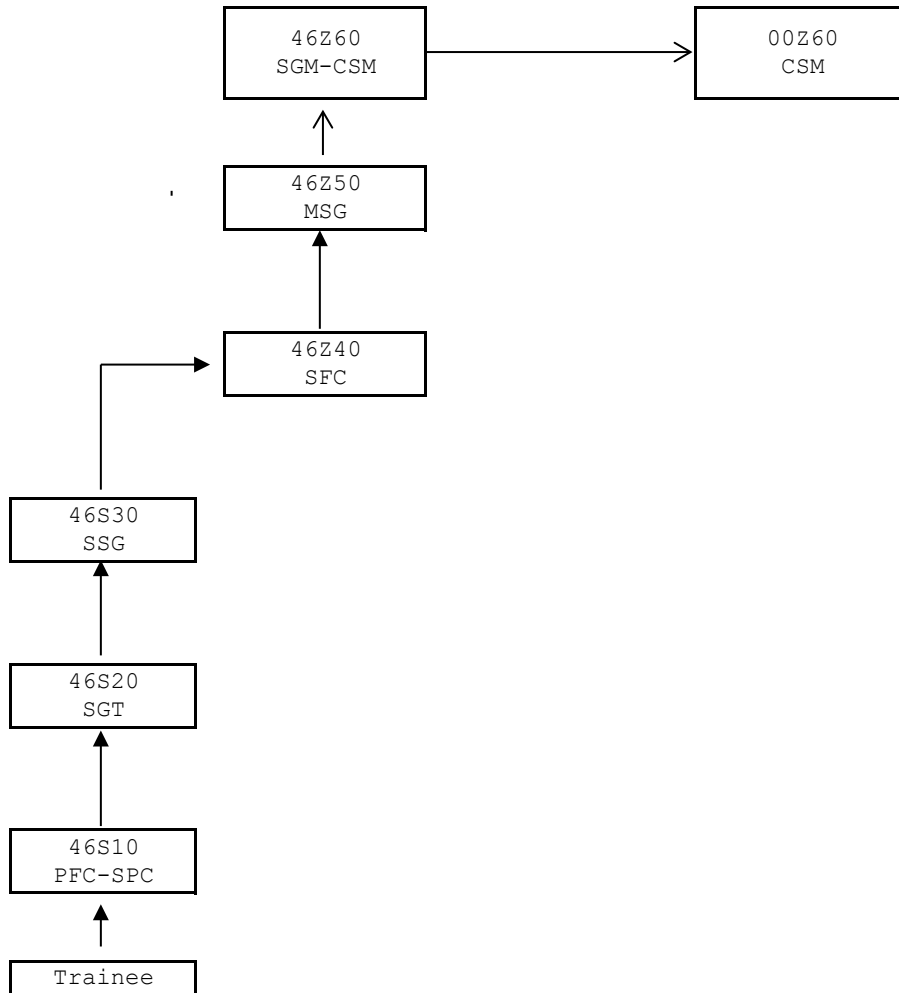

SUBSTITUTABILITY: None.

—————> Line of normal progression.

Figure 10-46. CMF 46 -- Public Affairs career progression (Effective 20181001)

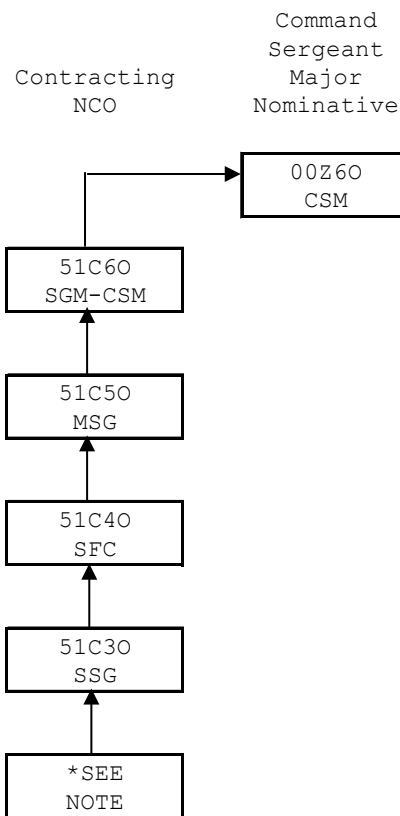

SUBSTITUTABILITY: None.

* SGT through SSG (non-promotable) may request accession into MOS 51C by (DA Form 4187). SM will be coded with ASI 4B until successful completion of MOSQ training at the Army Acquisition Center of Excellence. USAR and ARNG NCOs may alternatively complete Defense Acquisition University (DAU) Level I course in contracting and CON electives to become MOSQ. MOS 51C is not awarded until MOSQ training is successfully completed. Any enlisted MOS is considered a feeder MOS for MOS 51C.

Figure 10-51. CMF 51 - Acquisition, Logistics & Technology career progression (Effective 20180801)

Religious
Affairs
Specialist

Command
Sergeant
Major
Nominative

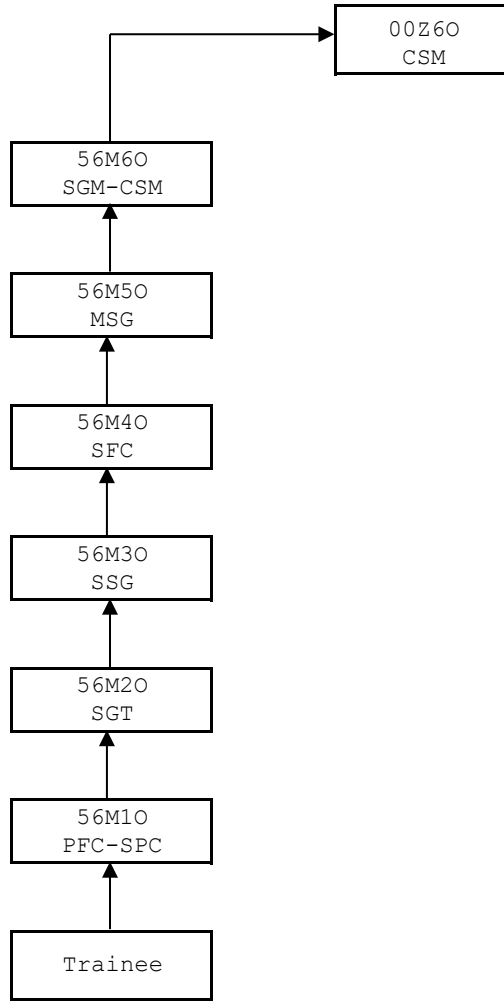

SUBSTITUTABILITY: None.

—————> Line of normal progression.

Figure 10-56. CME 56--Religious Support career progression.

BIOMEDICAL EQUIPMENT SPECIALIST PRACTICAL NURSING SPECIALIST DENTAL SPECIALIST PATIENT ADMINISTRATION SPECIALIST MEDICAL LOGISTICS SPECIALIST MEDICAL LABORATORY SPECIALIST NUTRITION CARE SPECIALIST RADIOLOGY SPECIALIST PHARMACY SPECIALIST PREVENTIVE MEDICINE SPECIALIST COMMAND SERGEANT MAJOR (NOMINATIVE) CHIEF MEDICAL NCO VETERINARY FOOD INSPECTION SPECIALIST ANIMAL CARE SPECIALIST ORTHOPEDIC SPECIALIST OPERATING ROOM SPECIALIST PHYSICAL THERAPY SPECIALIST OPTICAL LABORATORY SPECIALIST OCCUPATIONAL THERAPY SPECIALIST COMBAT MEDIC SPECIALIST RESPIRATORY SPECIALIST BEHAVIORAL HEALTH SPECIALIST EYE SPECIALIST

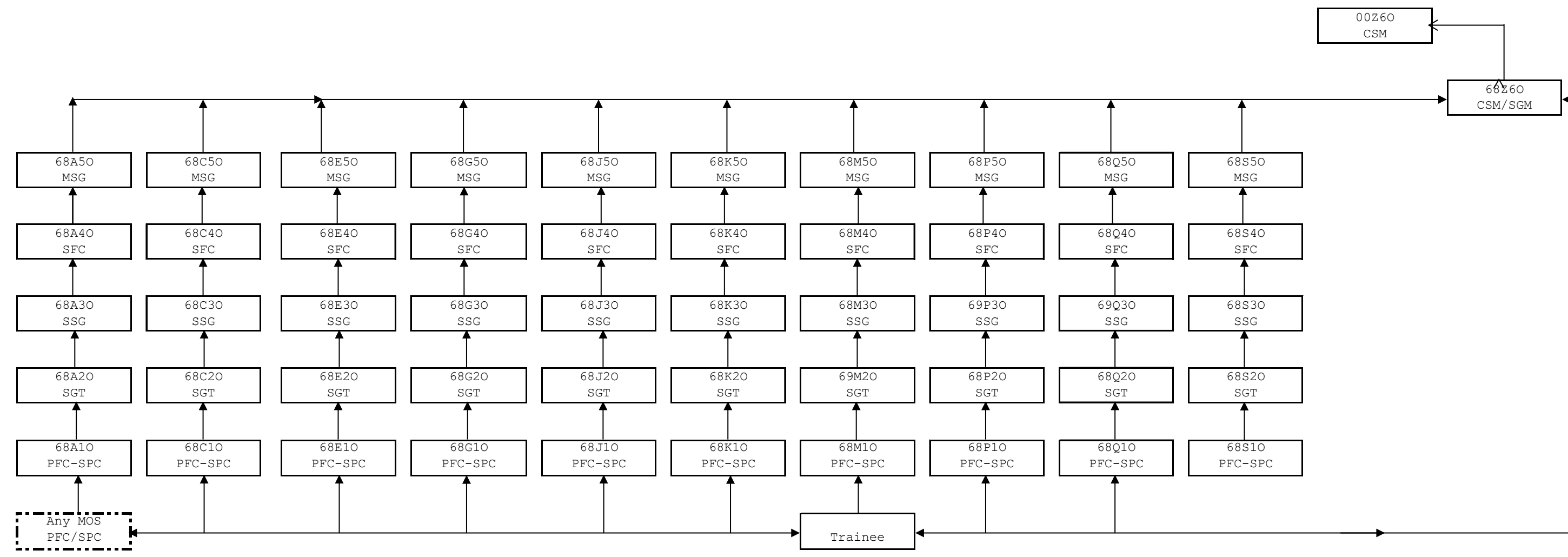

SUBSTITUTABILITY: Any CMP 68 MOS can serve in positions of First Sgt, Operations, Intel/plans, Tng, IG, EOA, or Detachment Sgt at the MSG and SFC level only.

Figure 10-68a. CMP 68 - Medical career progression (Effective 202110)

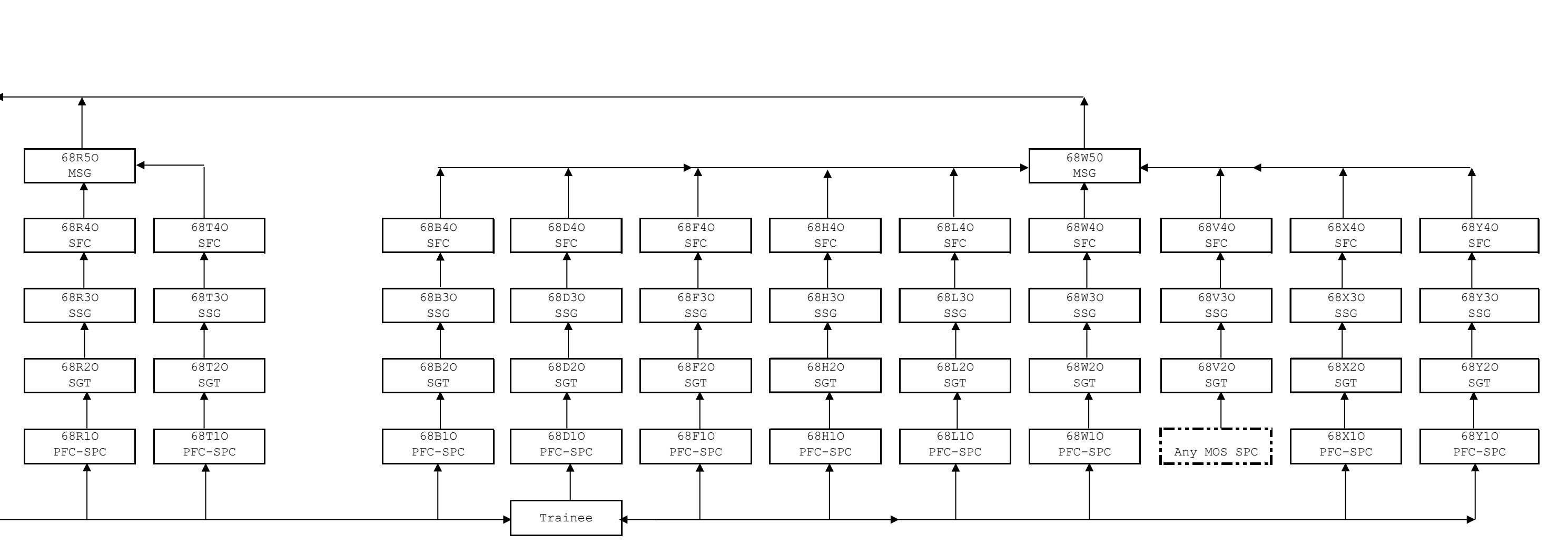
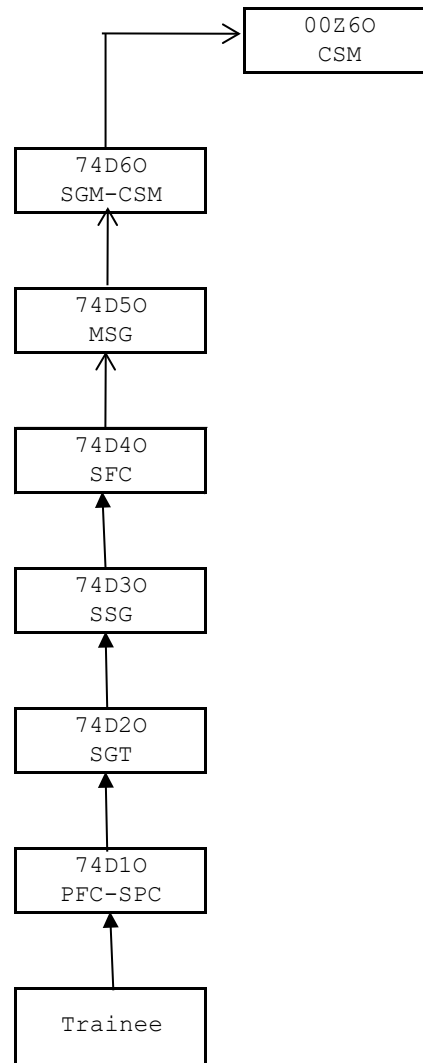

Figure 10-68b. CMP 68 - Medical career progression (Effective 202210)

Chemical
Biological
Radiological
and Nuclear
Specialist

Command
Sergeant
Major
Nominative



SUBSTITUTABILITY: None.

—————> Line of normal progression.

(Effective 1110)

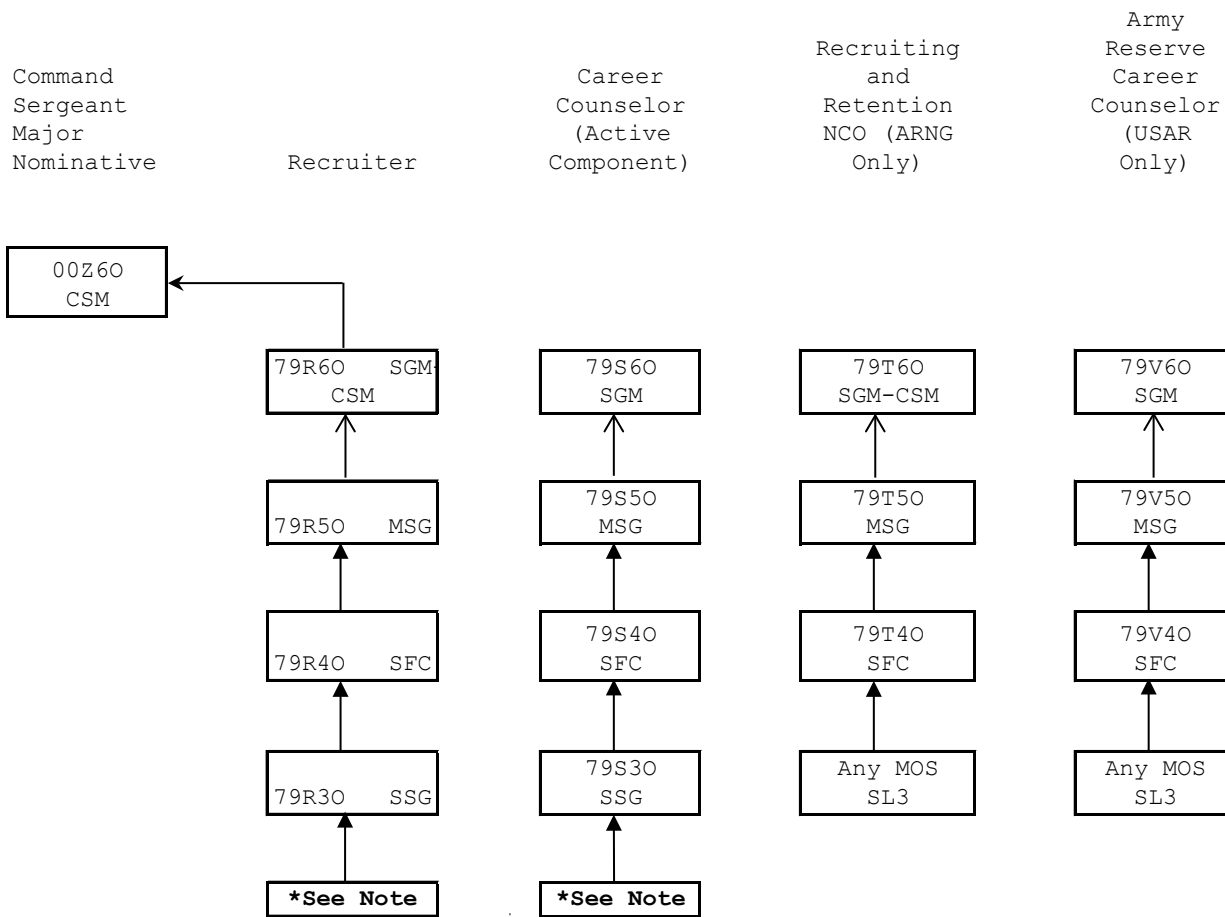

SUBSTITUTABILITY: None.

—————▶ Line of normal progression.

***NOTE:** Any MOS in skill level 2 thru 4 may be reclassified into MOS 79R. Any MOS in skill level 2 thru 3 may be reclassified into MOS 79S.

Figure 10-79. CMF 79 - Recruiting and Retention Career Progression

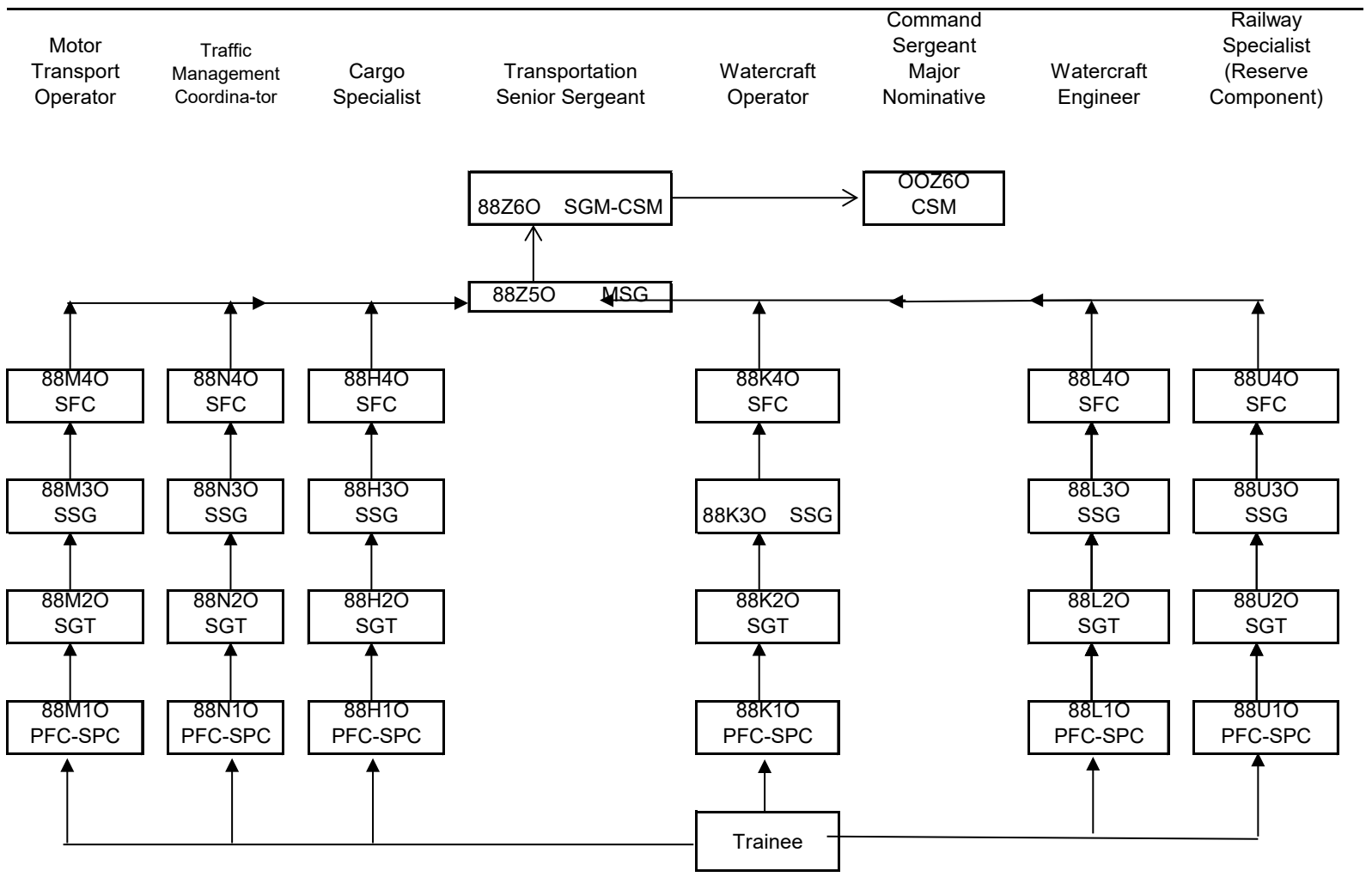

SUBSTITUTABILITY: None

—————> Line of normal progression.

Figure 10-88a. CMF 88 - Transportation career progression (Effective 201610)

Explosive Ordnance Disposal Specialist Ammunition Specialist Ammunition Stock Control and Accounting Specialist Command Sergeant Major Nominative

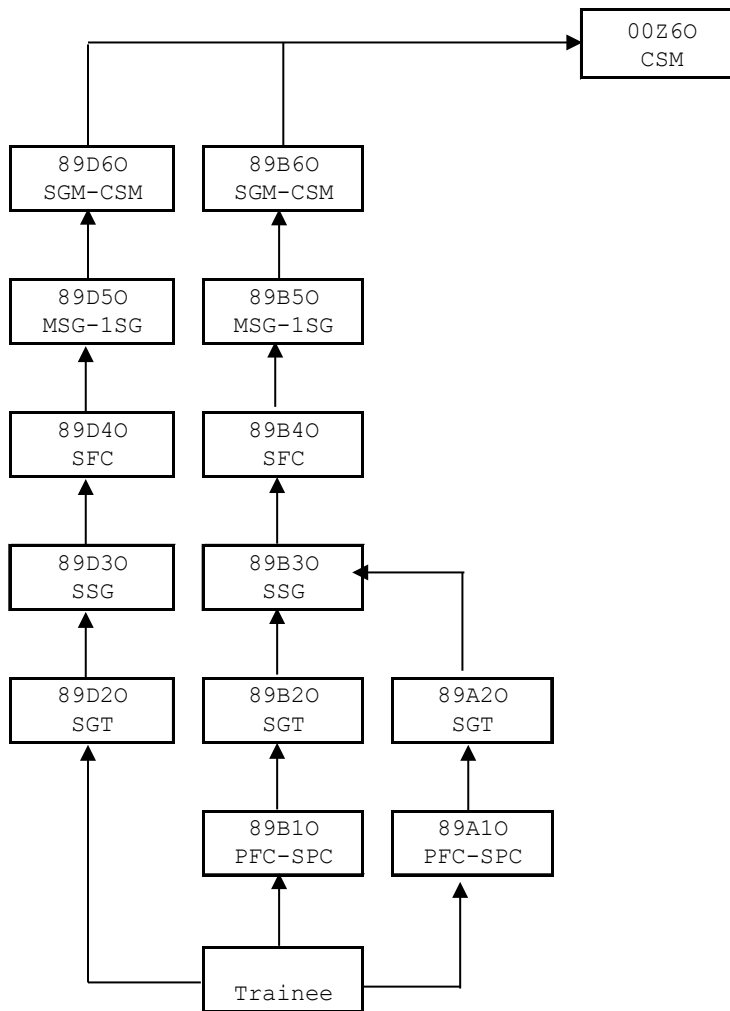

SUBSTITUTABILITY: Between 89A and 89B at skill level 1 and 2 only, if 89B previously performed Ammunition Stock Control and Accounting Specialist duties prior to October 2007.

→ progression.

Figure 10-89. CMF 89 - Ammunition career progression (Effective 202310)

Explosive Ordnance Disposal Specialist	Ammunition Specialist	Ammunition Stock Control and Accounting Specialist	Command Sergeant Major Nominative
---	--------------------------	--	--

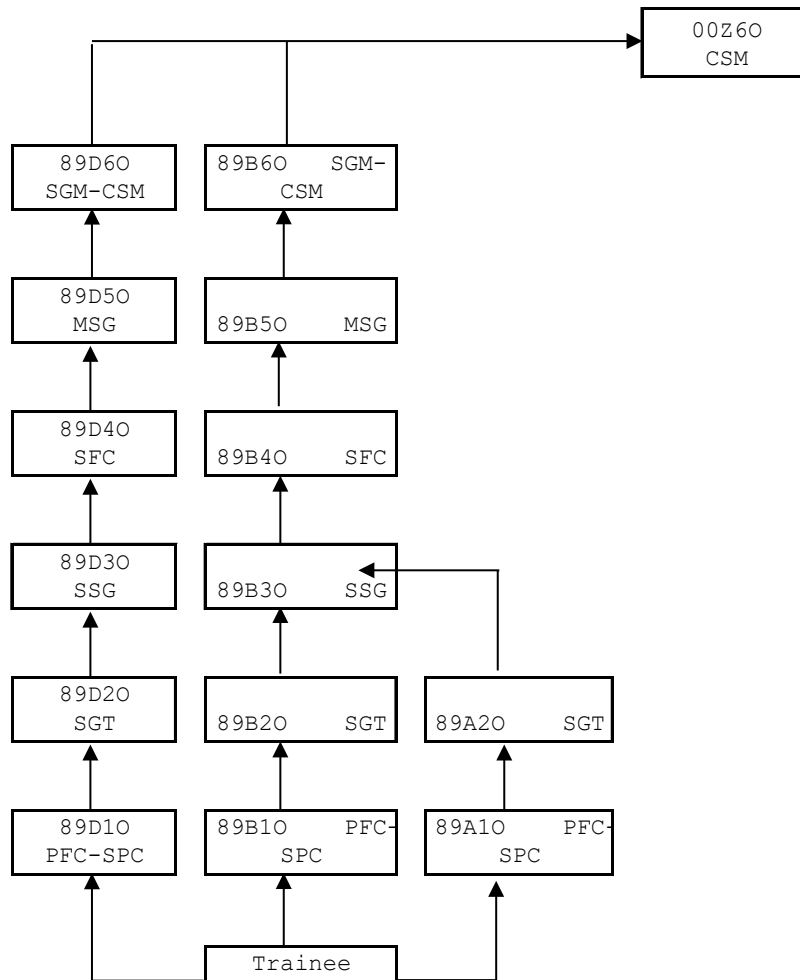

SUBSTITUTABILITY: Between 89A and 89B at skill level 1 and 2 only, if 89B previously performed Ammunition Stock Control and Accounting Specialist duties prior to October 2007.

—————> progression.

Figure 10-89. CMF 89 - Ammunition career progression (Effective 201110)

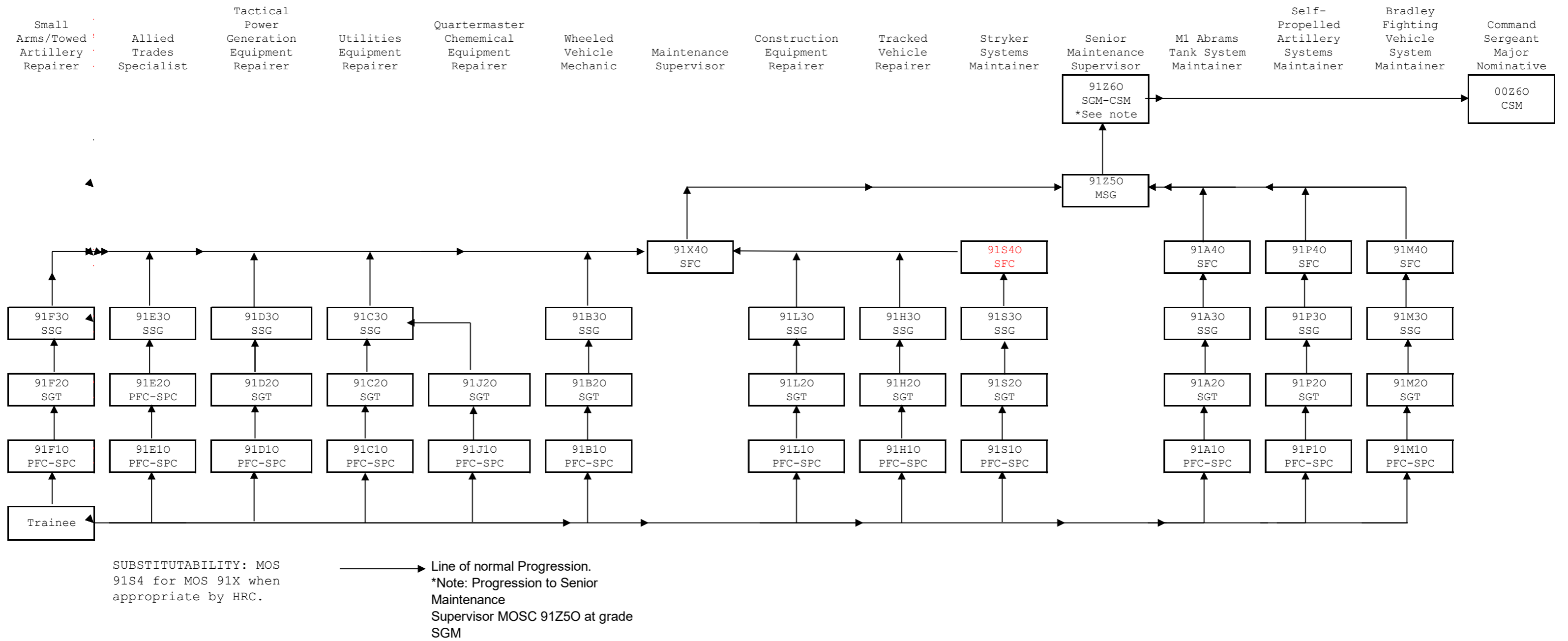
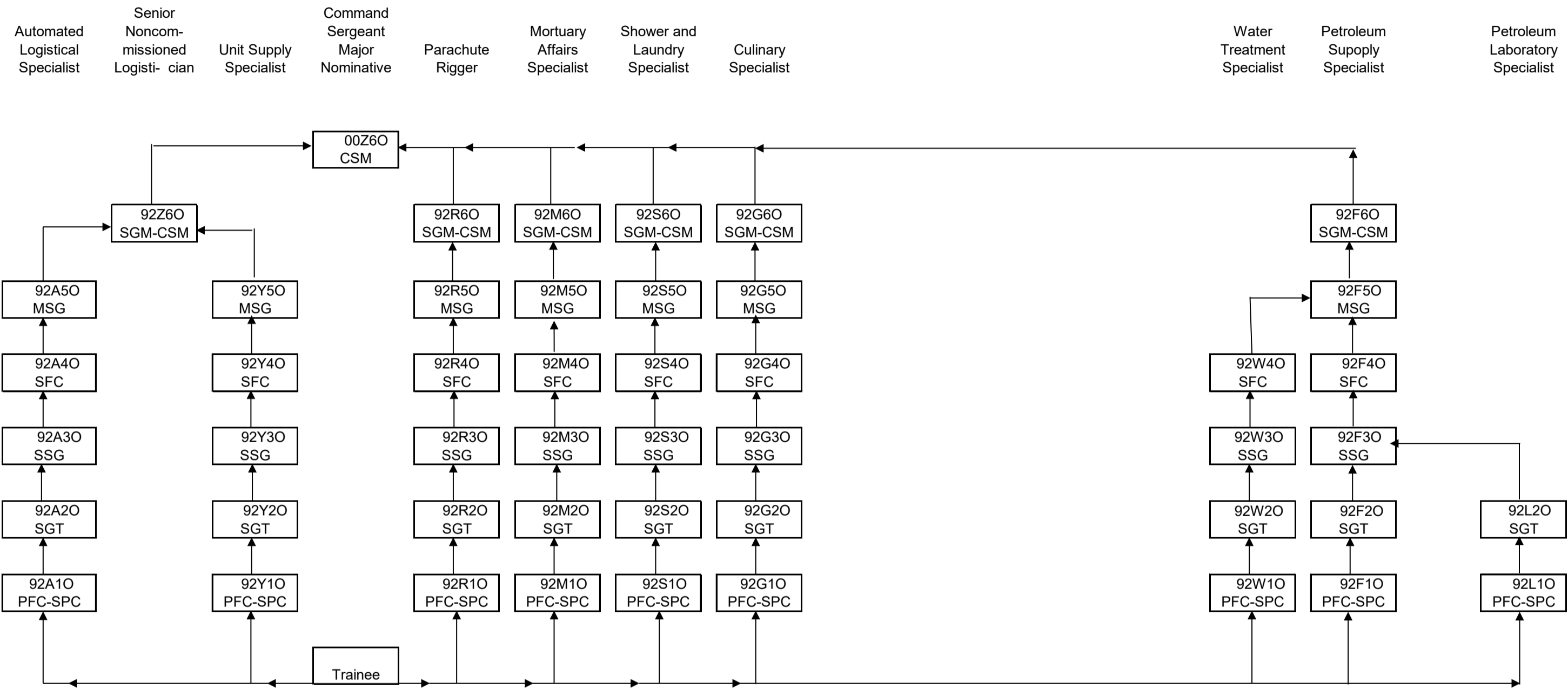

Figure 10-91c. CMF 91--Mechanical Maintenance Career Progression (Effective 201910)



SUBSTITUTABILITY: MOS 92A5M / 92Y5M
For 1SG positions in either MOS.

→ Line of normal progression.

← Line of normal progression.

Figure 10-92a. CMF 92 - Supply and Services career progression (Effective 202110)

Figure 10-92b. CMF 92 - Supply and Services career progression (Effective 202110)

Land Combat
Electronic
Missile System
Repairer

Radio Equipment
Repairer

Computer/
Detection
Systems Repairer

Senior
Electronic
Maintenance
Supervisor

Test Measurement
and Diagnostic
Equipment (TMDE)
Maintenance
Support
Specialist

Radar Repairer

94Z60
SGM-CSM

94Z50
MSG

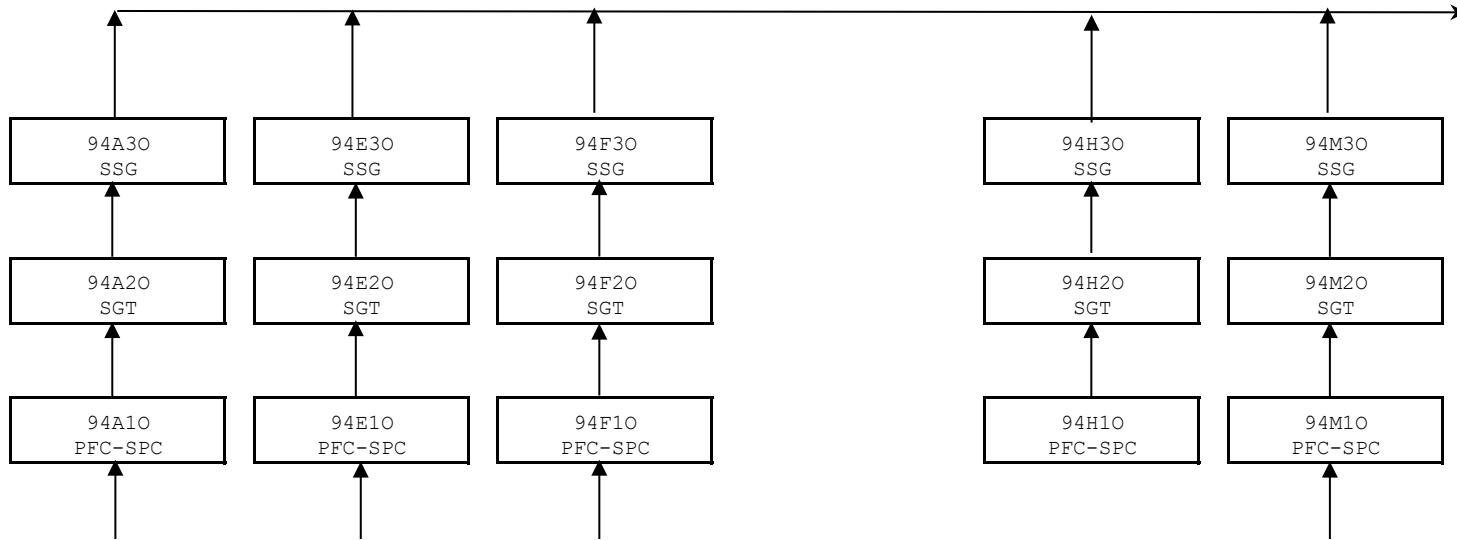

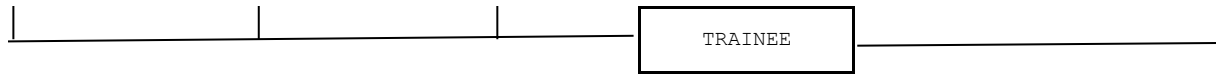

SUBSTITUTABILITY: None.

Figure 10-94a. CMF 94 - Electronic Maintenance and Calibr

Electronic
Maintenance
Supervisor

Multiple Launch
Rocket System
(MLRS) Repairer

Avionic and
Survivability
Equipment
Repairer

Short Range Air
Defense System
Repairer

Automated Test
Systems (ATS)
Operator and
Maintainer

Air Traffic
Control
Equipment
Repairer

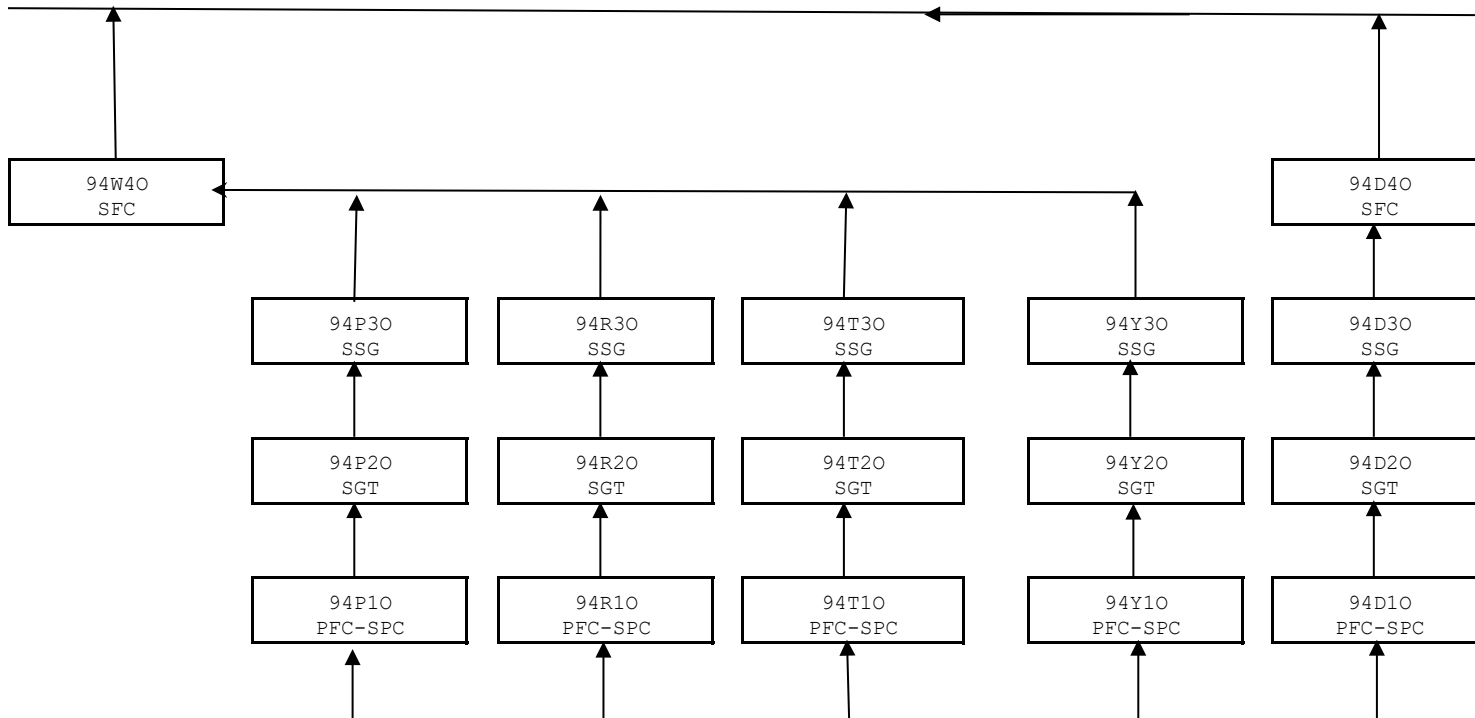



Figure 10-94c. CMF 94 - Electronic Maintenance and Calibration career progression (Effective 20181001)
